

KABELSCHLEPP

EasyTrax[®] series



PLASTIC CABLE CARRIERS
EASY INSTALLATION
WITH LAMELLA
TWO-COMPONENT TECHNOLOGY



EasyTrax® series

Extremely fast
cable laying thanks to
easy cable insertion





Inner heights
4.6 – 31 mm



Inner widths
7 – 78 mm



Pitch
11.5 – 45.5 mm



Additional load
up to 6 kg/m



Travel length unsupported
up to 4.8 m



Travel length gliding
up to 80 m



Travel speed
up to 10 m/s



Travel acceleration
up to 50 m/s²

All technical data and features depend on application and type. Let us know your requirements – we are here to help!

Fon: +49 (0) 2762 4003-0 or
e-mail: technik@kabelschlepp.de

kabelschlepp.de/
easytrax

Configure your cable carrier:
onlineengineer.de

Technical support:
technik@kabelschlepp.de

online-engineer.de
Cable Carrier Configurator

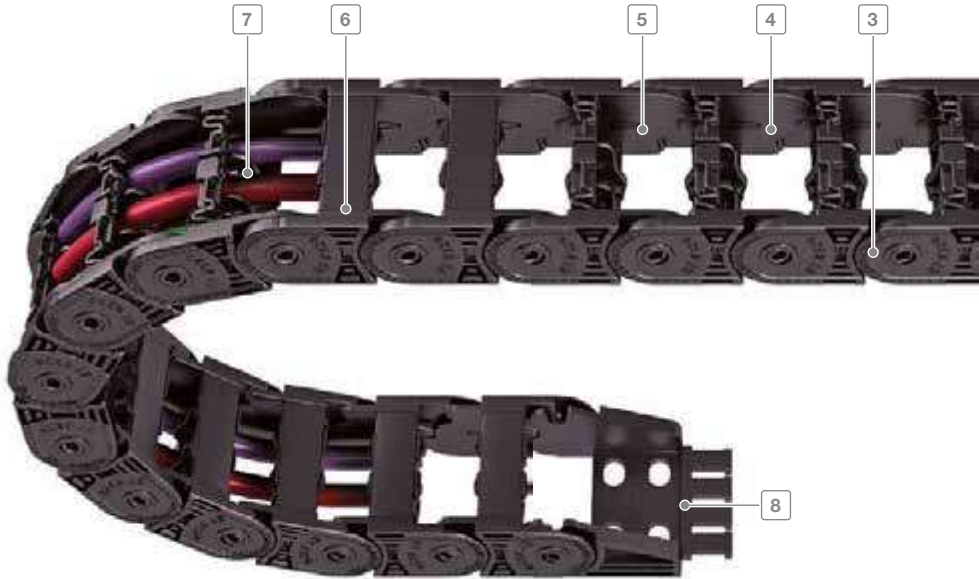

Features

- Extremely fast cable laying thanks to easy cable insertion
- Very high fill level due to the crossbar pivoting to the side – crossbars do not pivot into the cable space
- Each chain link consists of two different materials:
 - Hard cable carrier body made of glass fiber-reinforced material
 - Crossbar with flexible film hinge made of elastic special plastic
- Sturdy chain design
- High torsional rigidity
- Extensive unsupported length
- Extremely low noise due to integrated noise damping



Fast and easy installation of cables and hoses



Very high filling level



High side stability



Divider systems for reliable cable separation

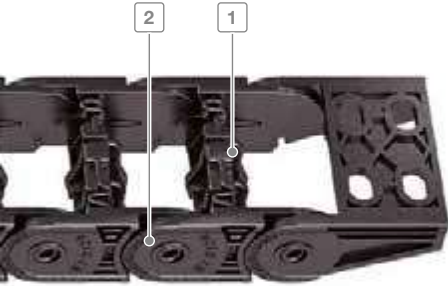

Example of inner distribution

- 1 Sturdy two-component design: hard cable carrier body, flexible film hinge
- 2 Chain links made of plastic
- 3 Extensive unsupported length
- 4 Inside space is gentle on the cables – no interfering edges
- 5 Extremely low noise due to integrated noise damping
- 6 For inside/outside opening
- 7 Dividers for cable separation
- 8 Single-part end connectors with and without integratable strain relief

Inner heights



Inner widths



Key for abbreviations on page 60

Selection criteria for EasyTrax®

- Where extremely fast cable laying is required
- For high fill levels
- Where an extensive unsupported length is required
- Where rigidity is required
- For low noise applications

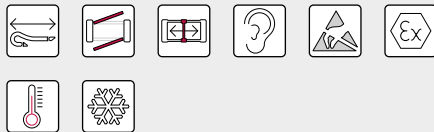

Assembly instructions on kabelschlepp.de/assembly

Type	h _i [mm]	B _i [mm]	t [mm]	Page
ET0115	4.6	7	11.5	8
ET0180	11.9	40	18	14
ET0320	18	15 – 65	32	24
ET0350	31	50	35	38
ET1455	25	78	45.5	48

Cable carrier design

Solid plastic cable carriers: side bands and end connectors made of plastic

Each chain link consists of two different materials:

- Hard cable carrier body made of glass fiber-reinforced material
- Flexible lamella crossbars made of elastic plastic



The two-component technology

The two-component technology of the EasyTrax® combines two seemingly incompatible features: **stability and flexibility**.

Cable carriers need to be extremely sturdy, with extensive unsupported length. At the same time, cables need to be inserted easily for fast cable laying.

The EasyTrax® meets these requirements thanks to its innovative design and material combination of a hard cable carrier body made from fiber glass reinforced material and crossbars with lamella crossbars made of elastic plastic.



high flexibility



high stability

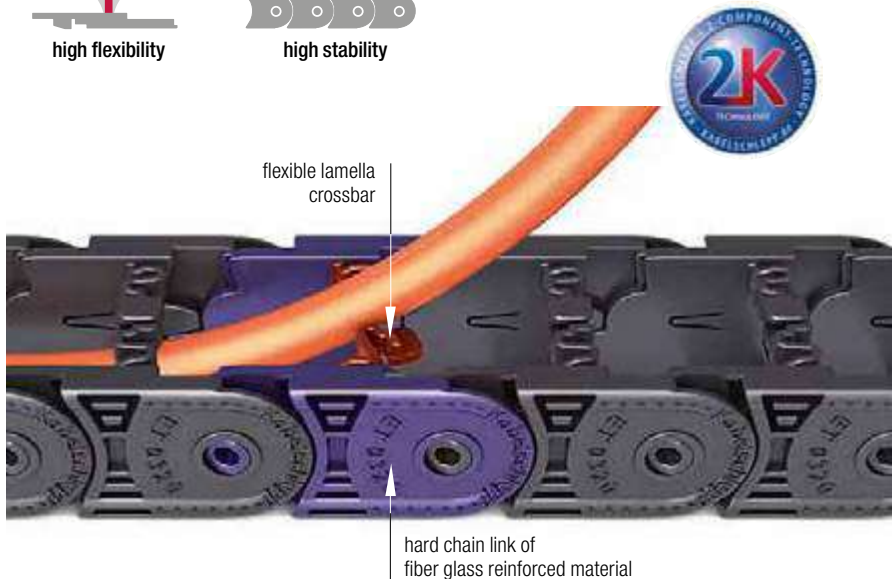

flexible lamella
crossbar

hard chain link of
fiber glass reinforced material

Comparison of dimensions

Manufacturer	h_i [mm]	h_G [mm]	t [mm]	Identical connection hole pattern
ET0320	18	25.5	32	yes
Competitive product	19	25	30.5	yes

Inner heights



Inner widths



Key for abbreviations on page 60

Assembly instructions on kabelschlepp.de/assembly

Comparison of bending moment

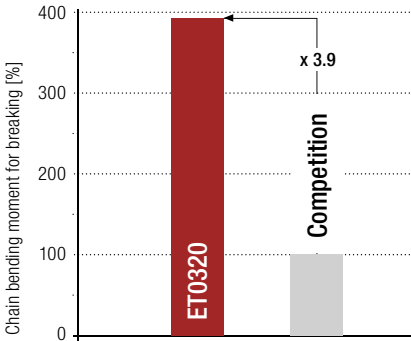

Comparison of bending strength

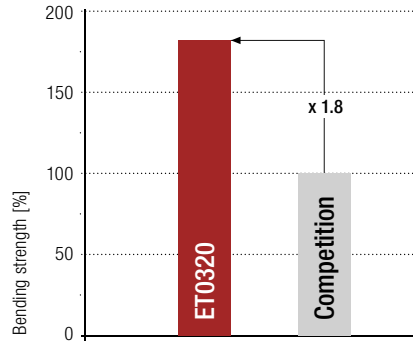

Load diagram

for unsupported length depending on additional load

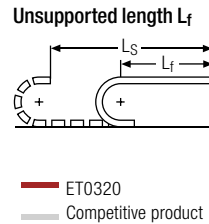
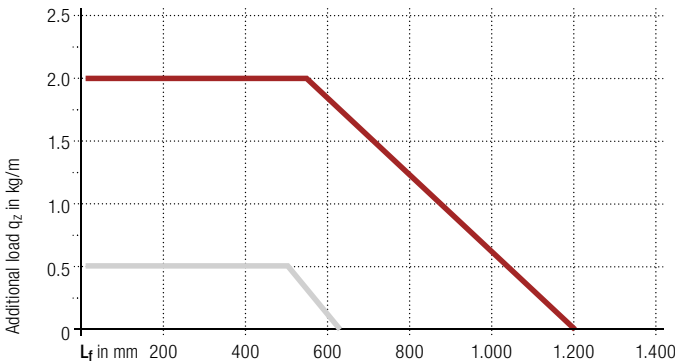

Advantages over competitive product

- 4 times bigger additional load compared to competitive product
- Double unsupported length compared to competitive product
- Faster cable laying at a higher utilization factor
- Low noise operation due to internal damping system
- High side stability through locking in the stroke system
- Dividers can be used for cable separation

ET0115

kabelschlepp.de/
easytrax



Pitch
11.5 mm



Height
4.6 mm

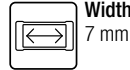

Width
7 mm



Bending radius
10 mm

Configure your cable carrier:
onlineengineer.de

Stay variants

Design 040



From page 10

Frame with lamella crossbars in the inner radius

- Weight-optimized plastic frame with particularly high torsional rigidity.
- Swivable on one side in any position.

Opening options

inside: Swivable.



Technical support:
technik@kabelschlepp.de



Unsupported arrangement

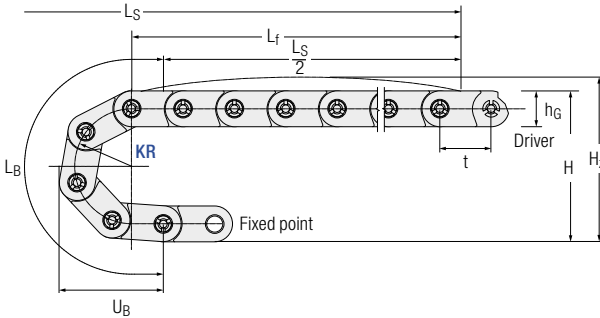

Unsupported length L_f

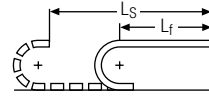

A sagging of the cable carrier is technically permitted for extended travel lengths, depending on the specific application.

Inner heights



Inner widths



Dynamics of unsupported arrangement		t
v_{max} [m/s]	a_{max} [m/s ²]	[mm]
3	10	11.5

Installation dimensions unsupported

KR [mm]	H [mm]	Hz [mm]	LB [mm]	UB [mm]
10	28	38	54.5	25.5

Key for abbreviations on page 60

Load diagram

for unsupported length depending on additional load

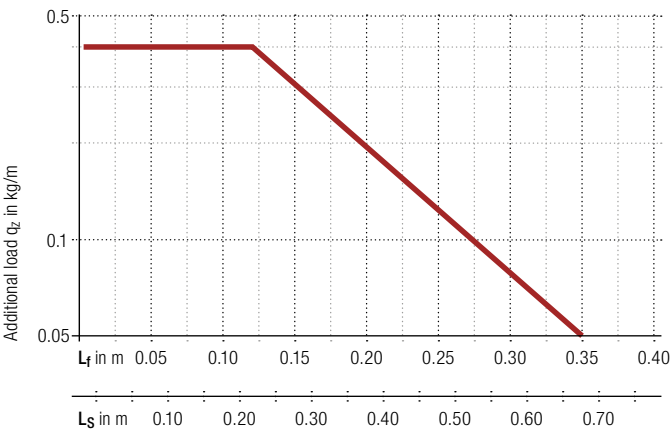

Calculating the cable carrier length

Cable carrier length L_k

$$L_k \approx \frac{L_s}{2} + L_B$$

Cable carrier length L_k rounded to pitch t

Unsupported length L_f

$$L_f = \frac{L_s}{2} + t$$

Fixed point offset L_f :
For off-center fixed point connections please contact us.

Assembly instructions on kabelschlepp.de/assembly

Order key on page 13



Stay variant 040 – with lamella crossbars in the inner radius

- Weight-optimized plastic frame with particularly high torsional rigidity.
- Swivable on one side in any position.
- **Opening options**
inside: Swivable.

kabelschlepp.de/
easytrax

Configure your cable carrier:
onlineengineer.de

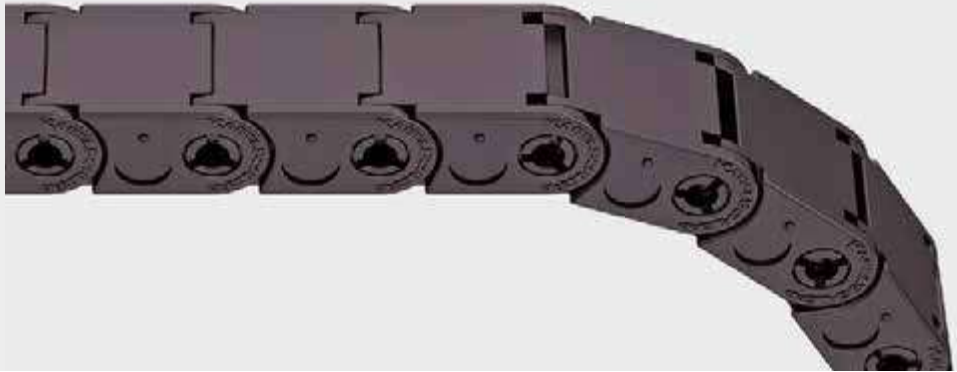

Stay arrangement on every chain link (VS)



B_i 7 mm

Technical support:
technik@kabelschlepp.de

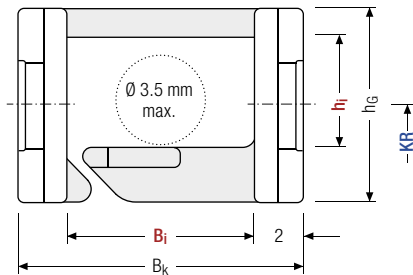

Calculating the cable carrier width

Outer width B_k

$$B_k = B_i + 4 \text{ mm}$$



The maximum cable diameter strongly depends on the bending radius and the desired cable type. Please contact us.

Pitch, inner height and chain link height

t [mm]	h _i [mm]	h _G [mm]
11.5	4.6	8

Inner heights



Bend radii

KR [mm]
10

Inner widths



Inner/outer width and intrinsic cable carrier weight

B _i [mm]	B _k [mm]	q _k [kg/m]
7	11	0.044

Key for abbreviations
on page 60

Order example



ET0115	·	040	·	7	·	10	·	1.280
Type		Stay variant		B _i [mm]		KR [mm]		L _k [mm]

Assembly instructions on
kabelschlepp.de/assembly



TRAXLINE® cables in motion

Hi-flex electric cables which were especially developed, optimized and tested for use in cable carriers can be found at traxline.de

More product information online



Assembly instructions etc.:
Receive additional info via your
smartphone or check online at
kabelschlepp.de/support



Configure your
custom cable carrier:
onlineengineer.de

Order key
on page 13



End connectors – plastic

The plastic end connectors can be **connected from above or below**.

kabelschlepp.de/
easytrax

Configure your cable carrier:
onlineengineer.de

Technical support:
technik@kabelschlepp.de

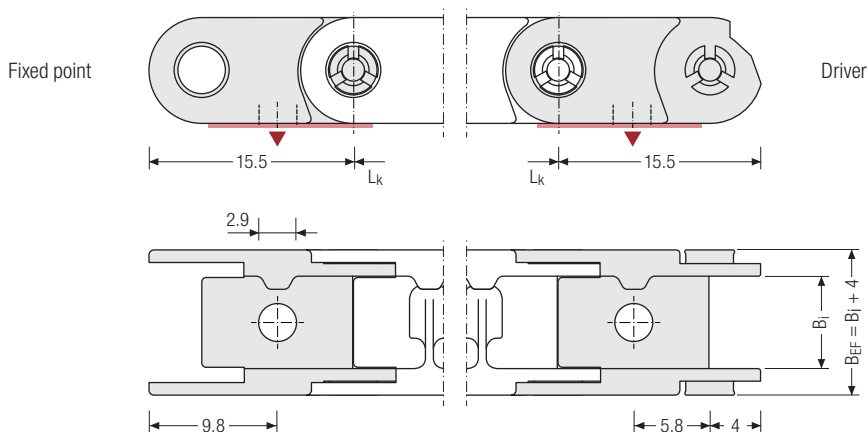

▲ Assembly options

 The end connectors can be swiveled in KR direction.

Connection variants

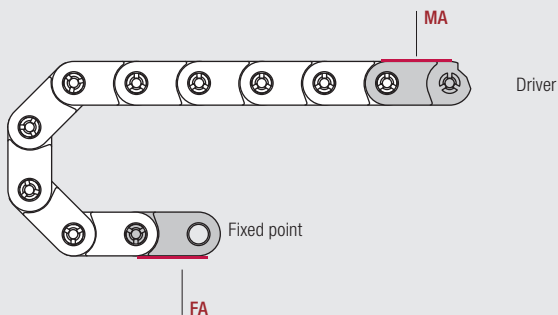

Connection point

- F** – fixed point
- M** – driver

Connection type

- A** – threaded joint outside (standard)

Order

Cable carrier

Type	Stay variant	B _i [mm]	KR [mm]	L _K [mm]
ET0115	040	7	10	
ET0115 Type	040 Stay variant	7 B _i [mm]	10 KR [mm]	276 L _K [mm]

Inner heights



Inner widths



 **International order specification INTOK:** Information about the International Order Key can be found in the chapter “International Order Key” from page 1.

Connection variant

End connector	Connection point	Connection type
End connector	F	A
End connector	M	A
End connector	F	A
End connector	M	A

Key for abbreviations
on page 60

Assembly instructions on
kabelschlepp.de/assembly

Order key
on page 13



ET0180

kabelschlepp.de/
easytrax



Teilung
18 mm



Höhe
11,9 mm



Breite
40 mm



Krümmungsradius
28 – 50 mm

Konfigurieren Sie ihre Energieführung:
onlineengineer.de

Stegbauarten

Bauart 030



Ab Seite 18

Rahmen mit Lamellenbügeln im Außenradius

- Gewichtsoptimierter Kunststoffrahmen mit besonders hoher Torsionssteifigkeit.
- Lamellen einseitig an beliebiger Position schwenkbar.

Öffnungsmöglichkeiten

Außen: Schwenkbar.

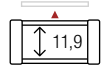

Technischer Support:
technik@kabelschlepp.de





Innen-
höhen



Innen-
breiten



Legende für Kurzzeichen
auf Seite 60

Montagehinweise auf
kabelschlepp.de/montage

Bestellschlüssel
auf Seite 22



ET0180 | Einbaumaße | Freitragend

Freitragende Anordnung

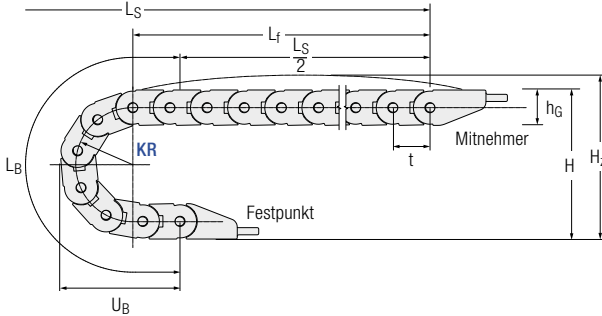

Freitragende Länge L_f

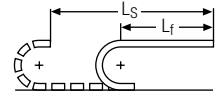

Bei längeren Verfahrwegen ist ein Durchhang der Energieführung je nach Einsatzfall technisch zulässig.

Dynamik bei freitragender Anordnung

v_{max} [m/s]	a_{max} [m/s ²]	t [mm]
10	50	18

Einbaumaße freitragend

KR [mm]	H [mm]	H _z [mm]	L _B [mm]	U _B [mm]
28	74	89	124	55
37	92	107	153	64
50	118	133	194	77

Belastungsdiagramm

für freitragende Länge in Abhängigkeit von der Zusatzlast

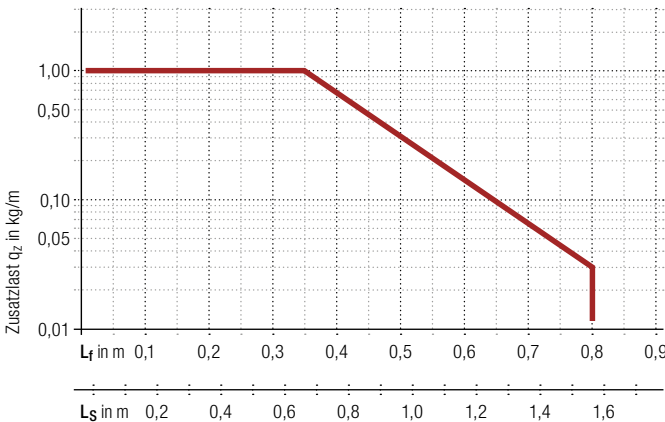

Berechnung der Kettenlänge

Kettenlänge L_k

$$L_k \approx \frac{L_S}{2} + L_B$$

Kettenlänge L_k aufgerundet auf Teilung t

Freitragende Länge L_f

$$L_f = \frac{L_S}{2} + t$$

i **Festpunktversatz L_f**: Bei außermittigem Festpunktanschluss sprechen Sie uns bitte an.

i Ketteneigengewicht $q_k = 0,25$ kg/m bei B₁ 10 mm.
Bei abweichender Innenbreite verändert sich die maximale Zusatzlast.

Gleitende Anordnung

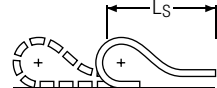
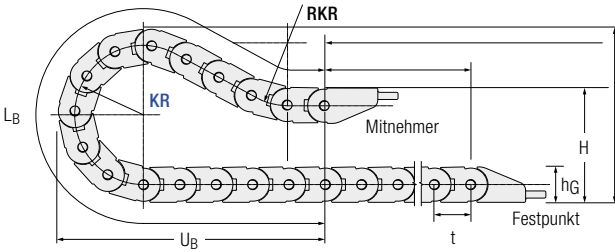

 Für weitere Informationen zur gleitenden Anordnung sprechen Sie uns bitte an.

Innenhöhen
11,9

Innenbreiten
40

Dynamik bei gleitender Anordnung		t
v _{max} [m/s]	a _{max} [m/s ²]	[mm]
3	30	18

 Die gleitende Energieführung muss in einem Kanal geführt werden. Unsere Techniker unterstützen Sie gerne bei der Projektierung – sprechen Sie uns an.

Berechnung der Kettenlänge

Kettenlänge L_k

$$L_k \approx \frac{L_s}{2} + L_B$$

Kettenlänge L_k aufgerundet auf Teilung t

Legende für Kurzzeichen
auf Seite 60

Montagehinweise auf
kabelschlepp.de/montage

Bestellschlüssel
auf Seite 22



TSUBAKI KABELSCHLEPP Beratungsservice

Bei Fragen zur Auslegung gleitender Energieführungen oder technischen Details, nehmen Sie doch einfach unsere technische Beratung unter technik@kabelschlepp.de in Anspruch. Wir helfen Ihnen gerne.



Stegbauart 030 – mit Lamellenbügeln im Außenradius

- Gewichtsoptimierter Kunststoffrahmen mit besonders hoher Torsionssteifigkeit.
- Lamellen einseitig an beliebiger Position schwenkbar.
- **Öffnungsmöglichkeiten**
Außen: Schwenkbar.

kabelschlepp.de/
easytrax

Konfigurieren Sie ihre Energieführung:
online-engineer.de



Steganordnung an jedem
Kettenglied (VS)



B_i von 40 mm

Technischer Support:
technik@kabelschlepp.de

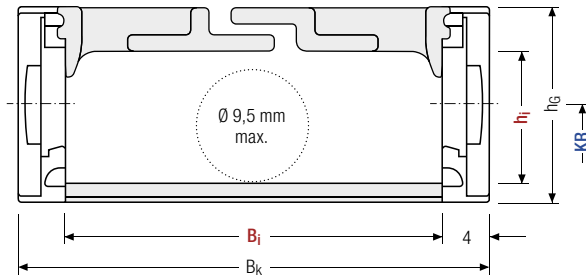

Berechnung der Kettenbreite

Außenbreite B_k

$$B_k = B_i + 8 \text{ mm}$$



Der maximale Leitungsdurchmesser ist stark abhängig von Krümmungsradius und dem gewünschten Leitungstyp. Bitte sprechen Sie uns an.

Teilung, Innenhöhe und Kettengliedhöhe

t [mm]	h _i [mm]	h _G [mm]
18	11,9	18



Krümmungsradien

KR [mm]		
28	37	50



Innen-, Außenbreite und Ketteneigengewicht

B _i [mm]	B _k [mm]	q _k [kg/m]
40	48	0,27

Legende für Kurzzeichen
auf Seite 60

Bestellbeispiel



ET0180	030	40	37	720
Typenreihe	Stegbauart	B _i [mm]	KR [mm]	L _k [mm]

Montagehinweise auf
kabelschlepp.de/montage

Bestellschlüssel
auf Seite 22



Einteilige Anschlusswinkel – Kunststoff (mit integrierter Zugentlastung)

Die Anschlusswinkel aus Kunststoff lassen sich von **oben oder unten anschließen**. Die Anschlussart kann durch Umstecken des Anschlusswinkels geändert werden.

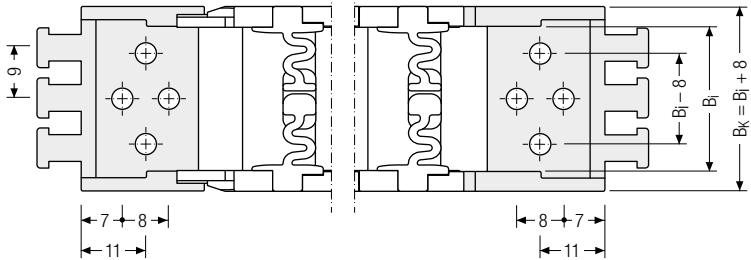
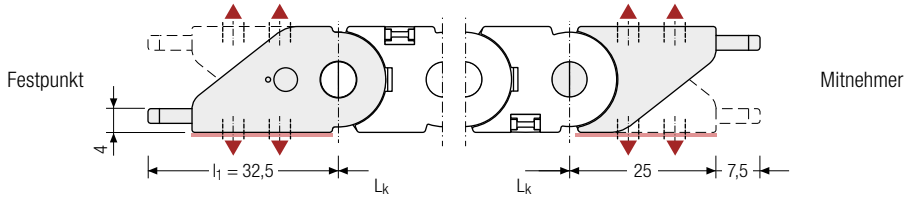

kabelschlepp.de/
easytrax

Konfigurieren Sie ihre Energieführung:
onlineengineer.de

Technischer Support:
technik@kabelschlepp.de

B_1 [mm]	B_k [mm]	n_z
40	48	4

▲ Montagemöglichkeiten

🔒 Die Anschlusswinkel sind nicht schwenkbar.

🔒 Für beugte Einbauverhältnisse sind auch kurze Anschlussstücke ohne Zugentlastung verfügbar. Bitte sprechen Sie uns an.

Anschlussvarianten

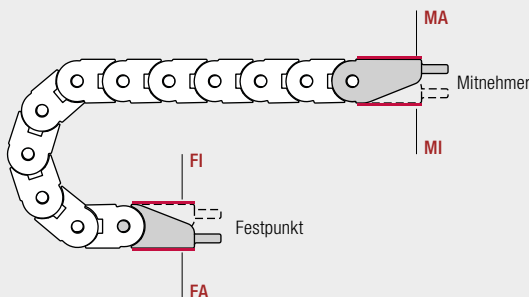

Anschlusspunkt

F – Festpunkt
M – Mitnehmer

Anschlussart

A – Verschraubung nach außen (Standard)
I – Verschraubung nach innen

Einteilige Anschlussstücke – Kunststoff

Die Anschlussstücke aus Kunststoff lassen sich von **oben oder unten anschließen**. Die Anschlussart kann durch Umstecken des Anschlussstücks geändert werden.

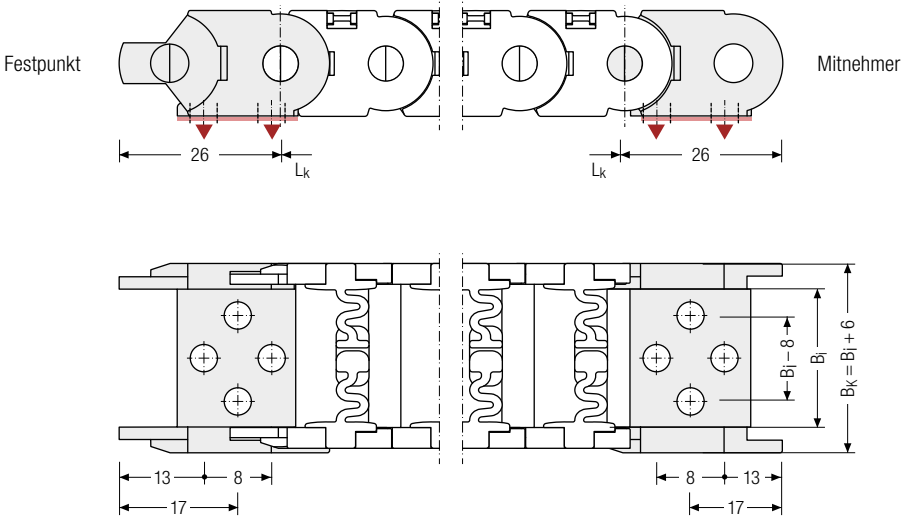

Innenhöhen

11,9

Innenbreiten

40

Legende für Kurzzeichen auf Seite 60

▲ Montagemöglichkeiten

 Die Anschlussstück sind nicht schwenkbar.

Montagehinweise auf kabelschlepp.de/montage

Anschlussvarianten

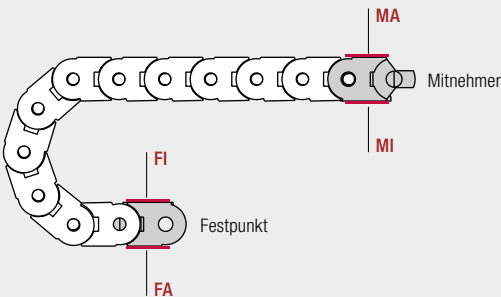

Anschlusspunkt

F – Festpunkt
M – Mitnehmer

Anschlussart

A – Verschraubung nach außen (Standard)
I – Verschraubung nach innen

Bestellschlüssel auf Seite 22



Bestellung

Energieführung

Typenreihe	Stegbauart	B _i [mm]	KR [mm]	L _K [mm]
			28	
			37	
ET0180	030	40	50	

ET0180	030	40	37	720
Typenreihe	Stegbauart	B _i [mm]	KR [mm]	L _K [mm]

 **Internationale Bestellbezeichnung intOK:**
Hinweise zum International Order Key finden Sie im Kapitel „International Order Key“ ab Seite 1.

Anschlussvariante

Anschlusselement	Anschlusspunkt	Anschlussart
	F	A
Anschlusswinkel	M	I

Anschlusswinkel	F	A
Anschlusswinkel	M	A

 Bitte geben Sie die gewünschte Anschlussvariante sowie die gewünschte Zugentlastungsart sowohl für den Festpunkt, als auch für den Mitnehmer an.

kabelschlepp.de/
easytrax

Konfigurieren Sie ihre Energieführung:
onlineengineer.de

Technischer Support:
technik@kabelschlepp.de

Zubehör

TRAXLINE® Leitungen für Energieführungen

Hochflexible Elektroleitungen, die speziell für den Einsatz in Energieführungsketten entwickelt, optimiert und getestet wurden.

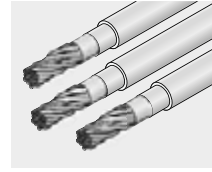

Innenhöhen

11,9

Innenbreiten

40

Führungskanäle

Bei gleitenden Anwendungen muss die Energieführung zwingend in einem Kanal geführt werden. Ein Abrutschen des Ober- vom Untertrum wird verhindert.

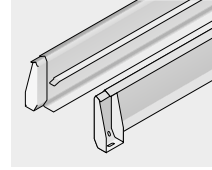

Legende für Kurzzeichen auf Seite 60

Montagehinweise auf kabelschlepp.de/montage

Bestellschlüssel auf Seite 22



TOTALTRAX® Komplettsysteme

Profitieren Sie von den Vorteilen eines TOTALTRAX®-Komplettsystems. Eine Komplettlieferrung aus einer Hand – auf Wunsch mit Garantiezertifikat! Erfahren Sie mehr unter kabelschlepp.de/totaltrax

Weitere Produktinformationen online



Montageanleitungen uvm.:
Mehr Infos auf Ihrem Smartphone
oder unter
kabelschlepp.de/support



Konfigurieren Sie hier Ihre
Energieführungskette:
onlineengineer.de

ET0320

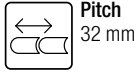

Pitch
32 mm

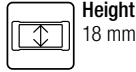

Height
18 mm



Width
15 – 65 mm



Bending radius
28 – 125 mm

kabelschlepp.de/
easytrax

Configure your cable carrier:
onlineengineer.de

Technical support:
technik@kabelschlepp.de

online-engineer.de
Cable Carrier Configurator

Stay variants

Design 030



From page 28

Frame with lamella crossbars in the outer radius

- Weight-optimized plastic frame with particularly high torsional rigidity.
- Swivable slats on one side in any position.

Opening options
outside: Swivable.

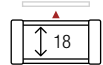

Design 040



From page 30

Frame with lamella crossbars in the inner radius

- Weight-optimized plastic frame with particularly high torsional rigidity.
- Swivable slats on one side in any position.

Opening options
inside: Swivable.

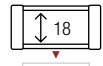



Subject to change.

EasyTrax®

Inner heights



Inner widths



Key for abbreviations
on page 60

Assembly instructions on
kabelschlepp.de/assembly

Order key
on page 36



Unsupported arrangement

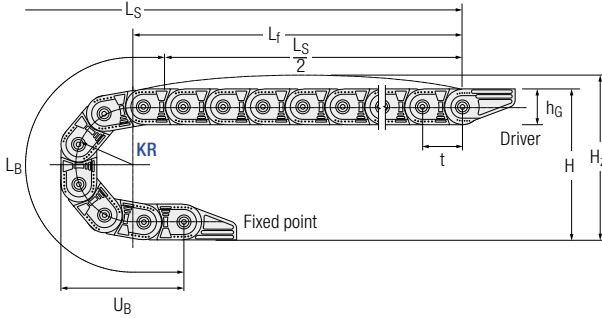

Unsupported length L_f

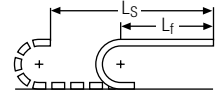

A sagging of the cable carrier is technically permitted for extended travel lengths, depending on the specific application.

Dynamics of unsupported arrangement

v_{max} [m/s]	a_{max} [m/s ²]	t [mm]
10	50	32

Installation dimensions unsupported

KR [mm]	H [mm]	H _z [mm]	L _B [mm]	U _B [mm]
28	81.5	101.5	152	73
38	101.5	121.5	184	83
48	121.5	141.5	215	93
75	175.5	195.5	300	120
100	225.5	245.5	379	145
125	275.5	295.5	457	170

Load diagram

for unsupported length depending on additional load

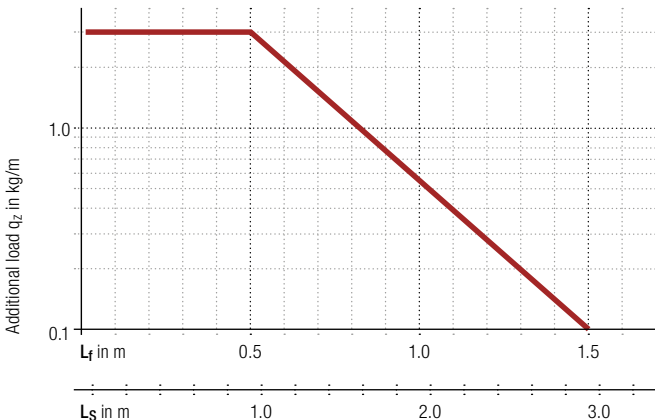

Calculating the cable carrier length

Cable carrier length L_k

$$L_k \approx \frac{L_S}{2} + L_B$$

Cable carrier length L_k rounded to pitch t

Unsupported length L_f

$$L_f = \frac{L_S}{2} + t$$



Fixed point offset L_f :

For off-center fixed point connections please contact us.



Intrinsic cable carrier weight $q_k = 0.40$ kg/m with B_i 38 mm. For other inner widths the maximum additional load changes.

Gliding arrangement

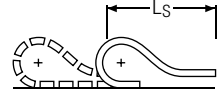
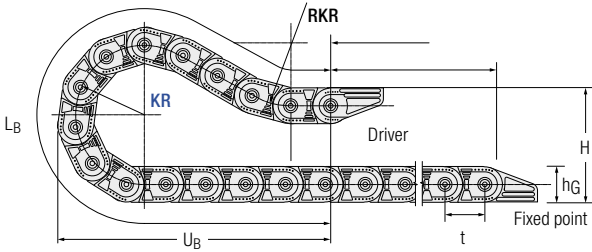

 For more information on gliding arrangement please contact us.

Inner heights
18

Inner widths
15
65

 Only design 030 may be used for gliding arrangements.

Dynamics of gliding arrangement		t
v _{max} [m/s]	a _{max} [m/s ²]	[mm]
2.5	25	32

 The gliding cable carrier has to be routed in a channel. Our engineers will be happy to help with project planning – please contact us.

Calculating the cable carrier length

Cable carrier length L_k

$$L_k \approx \frac{L_S}{2} + L_B$$

Cable carrier length L_k rounded to pitch t

Key for abbreviations on page 60

Assembly instructions on kabelschlepp.de/assembly

Order key on page 36



TSUBAKI KABELSCHLEPP Technical Support



If you have any questions about determining gliding cable carriers or other technical details please contact our technical support service at technik@kabelschlepp.de. We will be happy to help you.

Stay variant 030 – with lamella crossbars in the outer radius

- Weight-optimized plastic frame with particularly high torsional rigidity.
- Swivable slats on one side in any position.
- **Opening options outside:** Swivable.

kabelschlepp.de/
easytrax

Configure your cable carrier:
onlineengineer.de



Stay arrangement on every chain link (VS)



B_i from 15 – 65 mm

Technical support:
technik@kabelschlepp.de

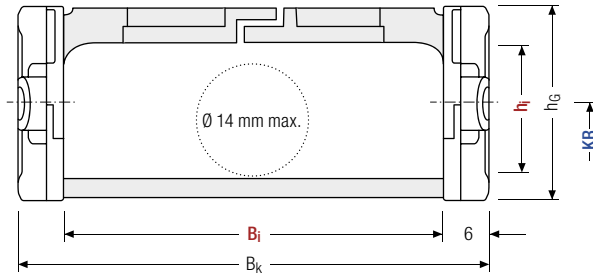

Calculating the cable carrier width

Outer width B_k

$$B_k = B_i + 12 \text{ mm}$$



The maximum cable diameter strongly depends on the bending radius and the desired cable type. Please contact us.



Pitch, inner height and chain link height

t [mm]	h _i [mm]	h _G [mm]
32	18	25.5

Inner heights



Bend radii

KR [mm]					
28	38	48	75	100	125

Inner widths



Inner/outer width and intrinsic cable carrier weight

B _i [mm]	B _k [mm]	q _k [kg/m]
15	27	0.35
25	37	0.38
38	50	0.40
50	62	0.43
65	77	0.45

Key for abbreviations on page 60

Order example



ET0320	·	030	·	50	·	100	·	1.280
Type		Stay variant		B _i [mm]		KR [mm]		L _k [mm]

Assembly instructions on kabelschlepp.de/assembly

Order key on page 36



Stay variant 040 – with lamella crossbars in the inner radius

kabelschlepp.de/
easytrax

- Weight-optimized plastic frame with particularly high torsional rigidity.
- Swivable slats on one side in any position.
- **Opening options inside:** Swivable.

Configure your cable carrier:
onlineengineer.de

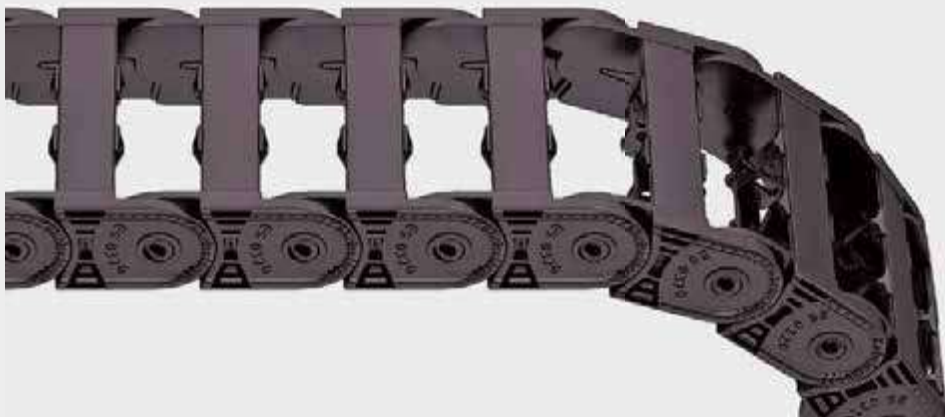

Stay arrangement on every chain link (VS)



B_i from 15 – 65 mm

Technical support:
technik@kabelschlepp.de

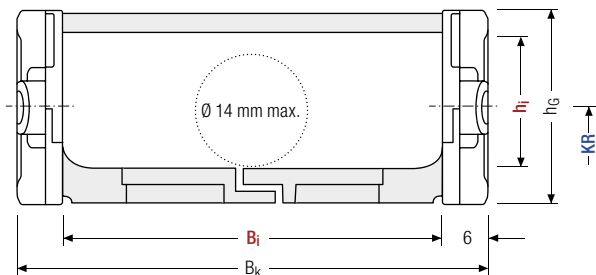

Calculating the cable carrier width

Outer width B_k

$$B_k = B_i + 12 \text{ mm}$$



The maximum cable diameter strongly depends on the bending radius and the desired cable type. Please contact us.



Design 040 is not suitable for gliding arrangement.



Pitch, inner height and chain link height

t [mm]	h _i [mm]	h _G [mm]
32	18	25.5

Inner heights



Bend radii

KR [mm]					
28	38	48	75	100	125

Inner widths



Inner/outer width and intrinsic cable carrier weight

B _i [mm]	B _k [mm]	q _k [kg/m]
15	27	0.35
25	37	0.38
38	50	0.40
50	62	0.43
65	77	0.45

Key for abbreviations on page 60

Order example



ET0320	040	50	100	1.280
Type	Stay variant	B _i [mm]	KR [mm]	L _k [mm]

Assembly instructions on kabelschlepp.de/assembly

Order key on page 36



Divider systems

As standard, the divider system is assembled at each 2nd chain link.

As standard, dividers and the complete divider system (dividers with height separations) can be moved in the cross section (**version A**).

kabelschlepp.de/
easytrax

Configure your cable carrier:
onlineengineer.de

Movable divider

Version A

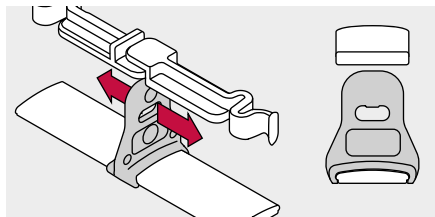

Divider system TSO without height separation

Version A				
S_T [mm]	W_f [mm]	a_{TL}/a_{TR} min [mm]	a_x min [mm]	a_c min [mm]
2	8	4	8	6

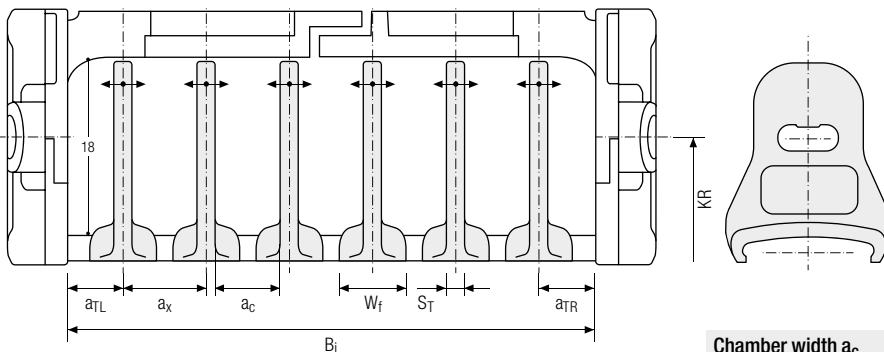

Chamber width a_c

$$a_c = a_x - S_T$$

Technical support:
technik@kabelschlepp.de





Inner heights



Inner widths



Key for abbreviations
on page 60

Assembly instructions on
kabelschlepp.de/assembly

Order key
on page 36



ET0320 | End Connectors | End Connectors

One part end connectors – plastic (with integrated strain relief)

The plastic end connectors can be **connected from above and below**. The connection type can be changed by reconnecting the end connector.

kabelschlepp.de/
easytrax

Configure your cable carrier:
onlineengineer.de

Technical support:
technik@kabelschlepp.de

online-engineer.de
Cable Carrier Configurator

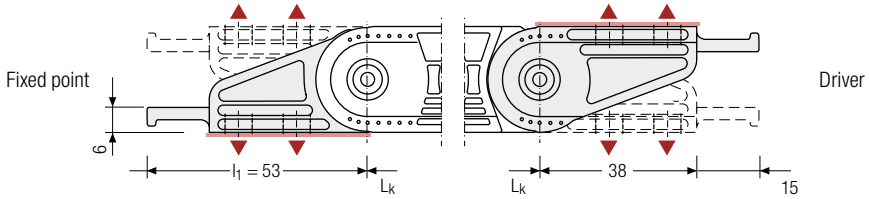

Bi: 15

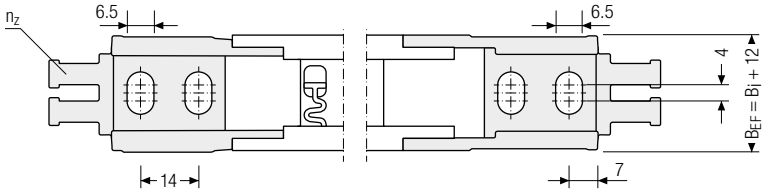

Bi: 25

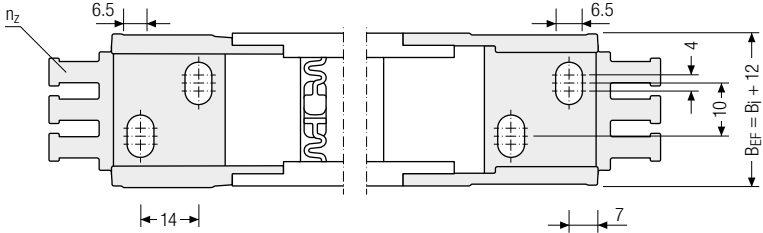

Bi: 38/50/65

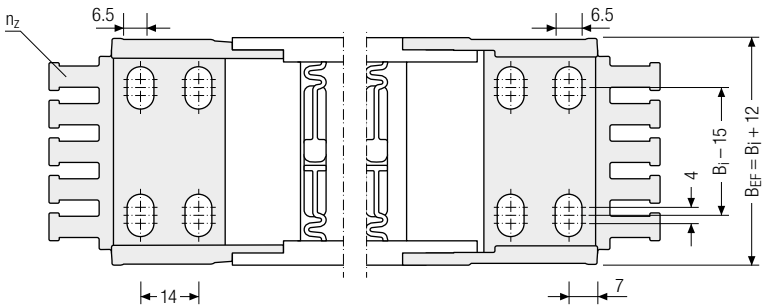

▲ Assembly options

One part end connectors – plastic (with integrated strain relief)

B_i [mm]	B_{EF} [mm]	n_z
15	27	2
25	37	3
38	50	4
50	62	5
65	77	6

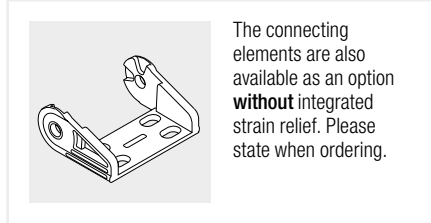

The connecting elements are also available as an option **without** integrated strain relief. Please state when ordering.

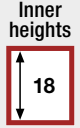

The end connectors cannot be swiveled.

Connection variants

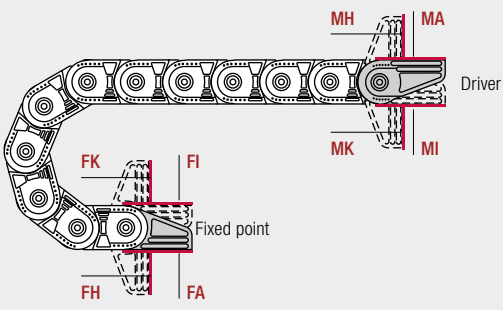

- Connection point**
F – fixed point
M – driver
- Connection type**
A – threaded joint outside (standard)
I – threaded joint inside
H – threaded joint outside rotated by 90°
K – threaded joint inside rotated by 90°

Key for abbreviations on page 60

Assembly instructions on kabelschlepp.de/assembly

Order key on page 36



Order

Cable carrier

Type	Stay variant	B _i [mm]	KR [mm]	L _K [mm]
ET0320		15	28	
		25	38	
		38	48	
	030	50	75	
	040	65	100	



i International order specification INTOK:
 Information about the International Order Key can be found in the chapter "International Order Key" from page 1.

Divider system

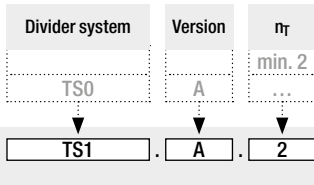

i Please state the designation of the divider system (**TS0**), version and number of dividers per cross section [n_T].

Connection variant

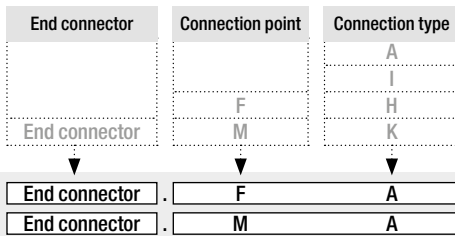

i Please state the desired connection variant as well as the desired strain relief type for the fixed point and for the driver.

kabelschlepp.de/
easytrax

Configure your cable carrier:
onlineengineer.de

Technical support:
technik@kabelschlepp.de

Accessories

TRAXLINE® cables in motion

Hi-flex electric cables which were especially developed, optimized and tested for use in cable carriers.

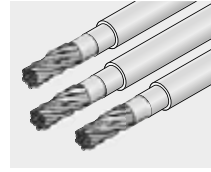

Inner heights



Inner widths



Support trays

An even surface is required for safe unrolling of the cable carrier. This is ensured by a support tray.

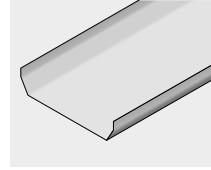

Key for abbreviations
on page 60

Assembly instructions on
kabelschlepp.de/assembly

Order key
on page 36



TOTALTRAX® complete systems

Benefit from the advantages of a TOTALTRAX® complete system. Complete delivery from a single source – with a guarantee certificate on request! Learn more at kabelschlepp.de/totaltrax

More product information online



Assembly instructions etc.:
Receive additional info via your
smartphone or check online at
kabelschlepp.de/support



Configure your
custom cable carrier:
onlineengineer.de

ET0350

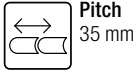

Pitch
35 mm

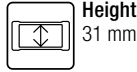

Height
31 mm

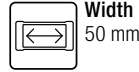

Width
50 mm

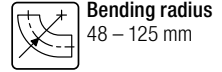

Bending radius
48 – 125 mm

kabelschlepp.de/
easytrax

Configure your cable carrier:
onlineengineer.de

Stay variants

Design 030



From page 40

Frame with lamella crossbars in the outer radius

- Weight-optimized plastic frame with particularly high torsional rigidity.
- Swivable slats on one side in any position.

Opening options
outside: Swivable.

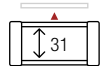

Design 040



From page 42

Frame with lamella crossbars in the inner radius

- Weight-optimized plastic frame with particularly high torsional rigidity.
- Swivable slats on one side in any position.

Opening options
inside: Swivable.

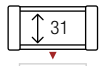

Technical support:
technik@kabelschlepp.de

Unsupported arrangement

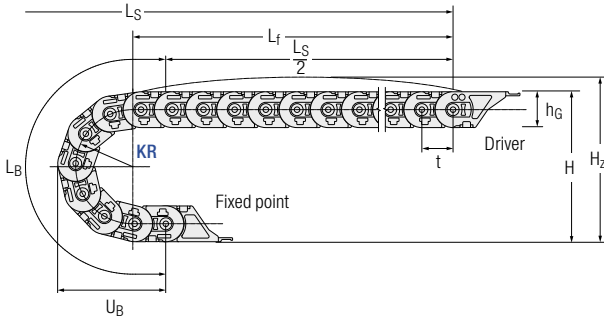

Unsupported length L_f

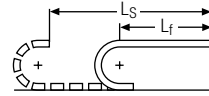

A sagging of the cable carrier is technically permitted for extended travel lengths, depending on the specific application.

Inner heights



Inner widths



Dynamics of unsupported arrangement		t
v_{max} [m/s]	a_{max} [m/s ²]	[mm]
5	20	35

Installation dimensions unsupported

KR [mm]	H [mm]	H _z [mm]	L _B [mm]	U _B [mm]
48	146	176	220	103
60	170	200	258	115
75	200	230	306	130
100	250	280	384	155
125	300	330	463	180

Key for abbreviations on page 60

Load diagram

for unsupported length depending on additional load

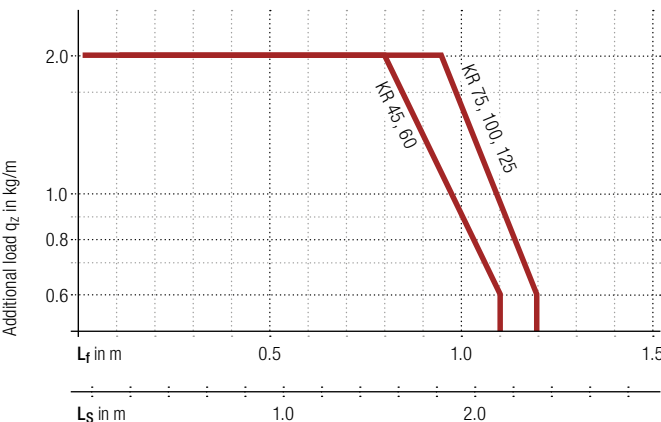

Calculating the cable carrier length

Cable carrier length L_k

$$L_k \approx \frac{L_s}{2} + L_B$$

Cable carrier length L_k rounded to pitch t

Unsupported length L_f

$$L_f = \frac{L_s}{2} + t$$

i Fixed point offset L_f :

For off-center fixed point connections please contact us.

Assembly instructions on kabelschlepp.de/assembly

Order key on page 46



i Intrinsic cable carrier weight $q_k = 0.2$ kg/m with B_i 16 mm. For other inner widths the maximum additional load changes.

Stay variant 030 – with lamella crossbars in the outer radius

- Weight-optimized plastic frame with particularly high torsional rigidity.
- Swivable slats on one side in any position.
- **Opening options outside:** Swivable.

kabelschlepp.de/
easytrax

Configure your cable carrier:
onlineengineer.de



Stay arrangement on every chain link (VS)



B_i from 50 mm

Technical support:
technik@kabelschlepp.de

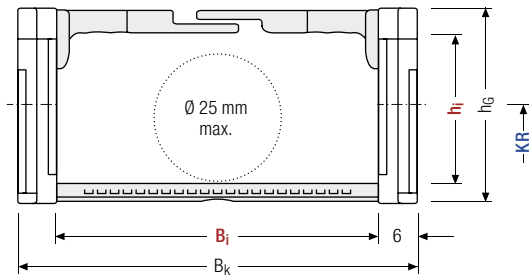

Calculating the cable carrier width

Outer width B_k

$$B_k = B_i + 12 \text{ mm}$$



The maximum cable diameter strongly depends on the bending radius and the desired cable type. Please contact us.



Pitch, inner height and chain link height

t [mm]	h _i [mm]	h _G [mm]
35	31	40

Inner heights



Bend radii

KR [mm]				
48	60	75	100	125

Inner widths



Inner/outer width and intrinsic cable carrier weight

B _i [mm]	B _k [mm]	q _k [kg/m]
50	62	0.8

Key for abbreviations on page 60

Order example



ET0350	·	030	·	50	·	100	·	700
Type		Stay variant		B _i [mm]		KR [mm]		L _k [mm]

Assembly instructions on kabelschlepp.de/assembly

Order key on page 46



Stay variant 040 – with lamella crossbars in the inner radius

- Weight-optimized plastic frame with particularly high torsional rigidity.
- Swivable slats on one side in any position.
- **Opening options inside:** Swivable.

kabelschlepp.de/
easytrax

Configure your cable carrier:
onlineengineer.de



Stay arrangement on every chain link (VS)



B_i from 50 mm

Technical support:
technik@kabelschlepp.de

online-engineer.de
Cable Carrier Configurator

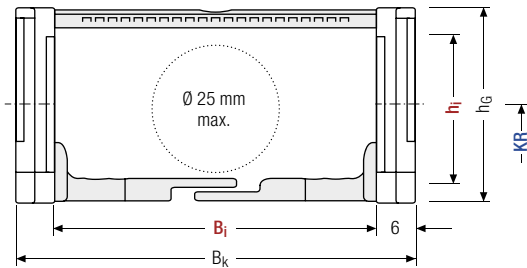

Calculating the cable carrier width

Outer width B_k

$$B_k = B_i + 12 \text{ mm}$$



The maximum cable diameter strongly depends on the bending radius and the desired cable type. Please contact us.



Information on the inner distribution of the cable carrier can be found on page 44.

Pitch, inner height and chain link height

t [mm]	h _i [mm]	h _G [mm]
35	31	40

Inner heights



Bend radii

KR [mm]				
48	60	75	100	125

Inner widths



Inner/outer width and intrinsic cable carrier weight

B _i [mm]	B _k [mm]	q _k [kg/m]
50	62	0.8

Key for abbreviations on page 60

Order example



ET0350	·	040	·	50	·	100	·	700
Type		Stay variant		B _i [mm]		KR [mm]		L _k [mm]

Assembly instructions on kabelschlepp.de/assembly

Order key on page 46



Divider systems

As standard, the divider system is assembled at each 2nd chain link.

As standard, dividers and the complete divider system (dividers with height separations) can be moved in the cross section (**version A**).

The dividers are easily attached to the stay for applications with transverse acceleration and for laterally recumbent applications by simply turning them.

The locking cams click into place in the locking grids in the crossbars (**version B**).

kabelschlepp.de/
easytrax

Configure your cable carrier:
onlineengineer.de

Movable divider

Version A (Standard)

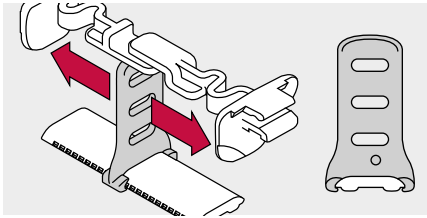

Fixable divider (2 mm grid)

Version B

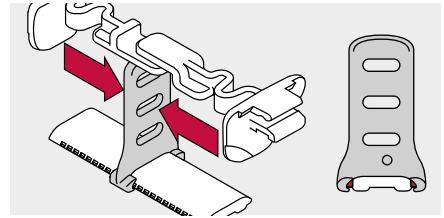

Divider system TSO without height separation

		Version A			Version B			
S_T [mm]	W_f [mm]	$a_{TL/a_{TR}}$ min [mm]	a_x min [mm]	a_c min [mm]	$a_{TL/a_{TR}}$ min [mm]	a_x min [mm]	a_c min [mm]	a_x Raster [mm]
2	6	3	6	4	4,5* / 5	6	4	2

* Only B_i 25

Technical support:
technik@kabelschlepp.de

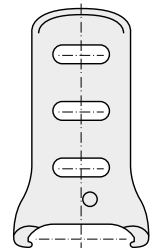
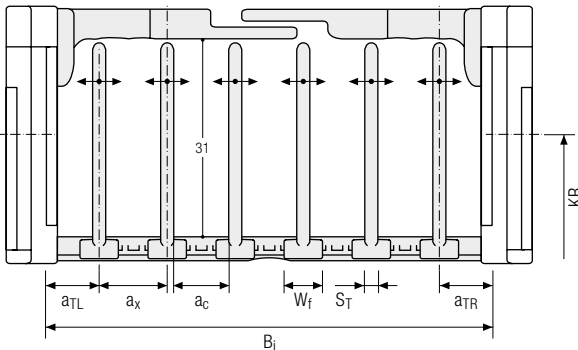

Chamber width a_c

$$a_c = a_x - S_T$$



ET0350 | End Connectors

One part end connectors – plastic (suitable for B_i 25 – 50)

The plastic end connectors can be **connected from above or below**. The connection type can be changed by reconnecting the end connector.

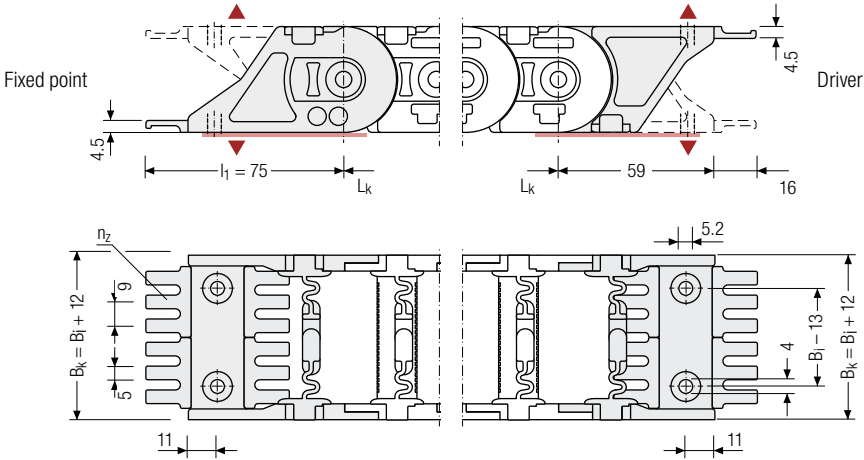

▲ Assembly options

B_i [mm]	B_k [mm]	n_z
50	62	6

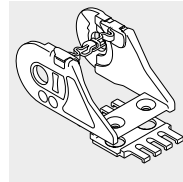

The end connectors are also available as an option **without** strain relief comb. Please state when ordering.

Connection variants

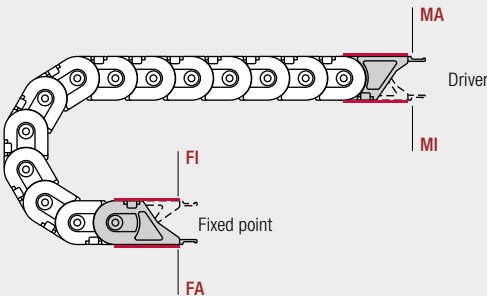

Connection point

- F** – fixed point
- M** – driver

Connection type

- A** – threaded joint outside (standard)
- I** – threaded joint inside



Order

kabelschlepp.de/
easytrax

Cable carrier

Type	Stay variant	B_i [mm]	KR [mm]	L_K [mm]
ET0350	040	50	48	700
			60	
			75	
			100	
			125	





 **International order specification INTOK:**
 Information about the International Order Key can be found in the chapter "International Order Key" from page 1.

Configure your cable carrier:
onlineengineer.de

Divider system

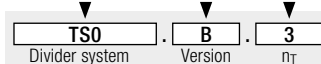
Divider system	Version	n_T
TS0	A	min. 2
	B	...





 Please state the designation of the divider system (**TS0, TS1**), version and number of dividers per cross section [n_T].

Technical support:
technik@kabelschlepp.de

Connection variant

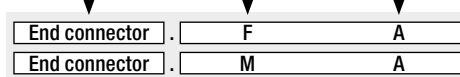
End connector	Connection point	Connection type
End connector	F	A
	M	I



 Please state the desired connection variant as well as the desired strain relief type for the fixed point and for the driver.

Accessories

TRAXLINE® cables in motion

Hi-flex electric cables which were especially developed, optimized and tested for use in cable carriers.

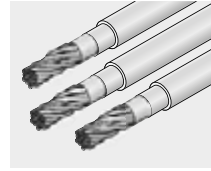

Inner heights



Inner widths



Support trays

An even surface is required for safe unrolling of the cable carrier. This is ensured by a support tray.

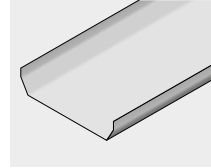

Key for abbreviations
on page 60

Assembly instructions on
kabelschlepp.de/assembly

Order key
on page 46



TOTALTRAX® complete systems

Benefit from the advantages of a TOTALTRAX® complete system. Complete delivery from a single source – with a guarantee certificate on request! Learn more at kabelschlepp.de/totaltrax

More product information online



Assembly instructions etc.:
Receive additional info via your
smartphone or check online at
kabelschlepp.de/support



Configure your
custom cable carrier:
onlineengineer.de

ET1455



Pitch
45.5 mm

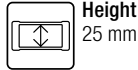

Height
25 mm



Width
78 mm



Bending radius
52 – 200 mm

kabelschlepp.de/
easytrax

Configure your cable carrier:
onlineengineer.de

Technical support:
technik@kabelschlepp.de

online-engineer.de
Cable Carrier Configurator



Stay variants

Design 030



From page 52

Frame with lamella crossbars in the outer radius

- Weight-optimized plastic frame with particularly high torsional rigidity.
- Swivable slats on one side in any position.

Opening options
outside: Swivable.

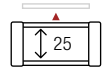

Design 040



From page 54

Frame with lamella crossbars in the inner radius

- Weight-optimized plastic frame with particularly high torsional rigidity.
- Swivable slats on one side in any position.

Opening options
inside: Swivable.

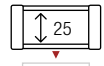



Supplied in a range.

EasyTrax®

Inner heights



Inner widths



Key for abbreviations on page 60

Assembly instructions on kabelschlepp.de/assembly

Order key on page 58



Unsupported arrangement

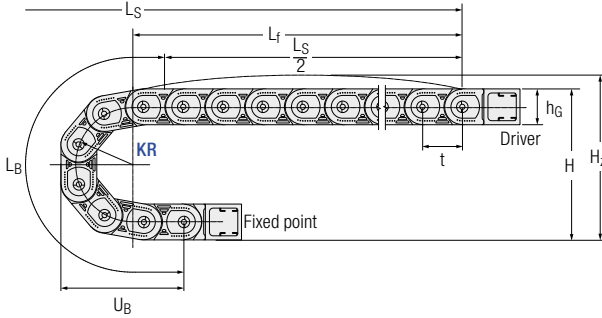

Unsupported length L_f

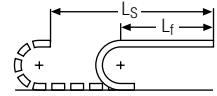

A sagging of the cable carrier is technically permitted for extended travel lengths, depending on the specific application.

kabelschlepp.de/
easytrax

Configure your cable carrier:
onlineengineer.de

Technical support:
technik@kabelschlepp.de

online-engineer.de
Cable Carrier Configurator

Dynamics of unsupported arrangement		t
v_{max} [m/s]	a_{max} [m/s ²]	[mm]
10	50	45.5

Installation dimensions unsupported

KR [mm]	H [mm]	H _z [mm]	L _B [mm]	U _B [mm]	KR [mm]	H [mm]	H _z [mm]	L _B [mm]	U _B [mm]
52	140	165	255	116	150	336	361	563	214
65	166	191	296	129	180	396	421	657	244
95	226	251	390	159	200	436	461	720	264
125	286	211	484	189					

Load diagram

for unsupported length depending on additional load

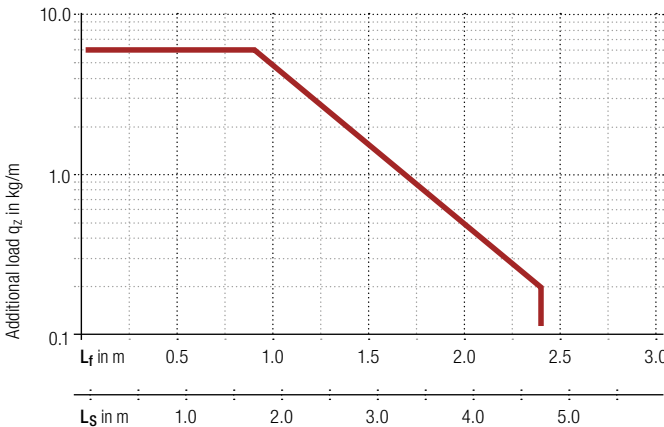

Calculating the cable carrier length

Cable carrier length L_k

$$L_k \approx \frac{L_S}{2} + L_B$$

Cable carrier length L_k rounded to pitch t

Unsupported length L_f

$$L_f = \frac{L_S}{2} + t$$



Fixed point offset L_f :

For off-center fixed point connections please contact us.



Intrinsic cable carrier weight $q_k = 0.75$ kg/m with B_i 38 mm.
For other inner widths the maximum additional load changes.

Gliding arrangement

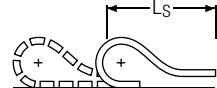
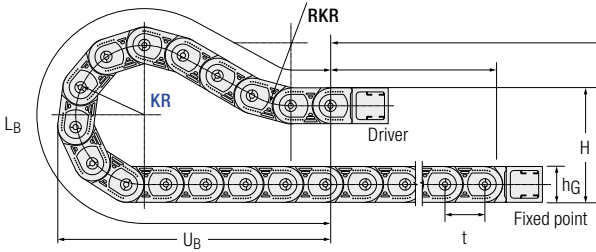

 For more information on gliding arrangement please contact us.

Inner heights
25

Inner widths
78

 Only design 030 may be used for gliding arrangements.

Dynamics of gliding arrangement		t
v _{max} [m/s]	a _{max} [m/s ²]	[mm]
2.5	20	45.5

 The gliding cable carrier has to be routed in a channel. Our engineers will be happy to help with project planning – please contact us.

Calculating the cable carrier length

Cable carrier length L_k

$$L_k \approx \frac{L_s}{2} + L_B$$

Cable carrier length L_k rounded to pitch t

Key for abbreviations on page 60

Assembly instructions on kabelschlepp.de/assembly

Order key on page 58



TSUBAKI KABELSCHLEPP Technical Support

If you have any questions about determining gliding cable carriers or other technical details please contact our technical support service at technik@kabelschlepp.de. We will be happy to help you.



Stay variant 030 – with lamella crossbars in the outner radius

kabelschlepp.de/
easytrax

Configure your cable carrier:
onlineengineer.de

- Weight-optimized plastic frame with particularly high torsional rigidity.
- Swivable slats on one side in any position.
- **Opening options outside:** Swivable.



Stay arrangement on every chain link (VS)



B_i from 78 mm

Technical support:
technik@kabelschlepp.de

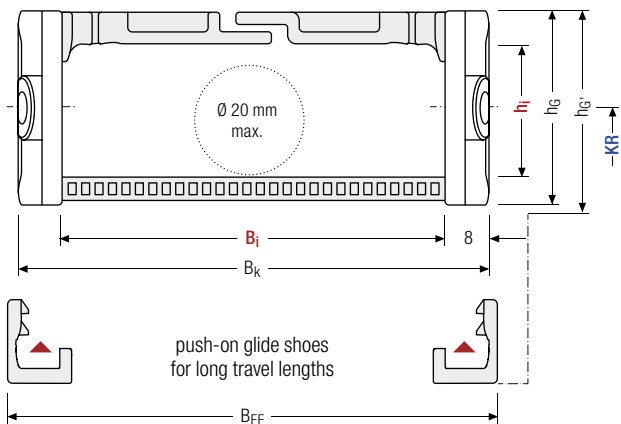

Calculating the cable carrier width

Outer width B_k

$$B_k = B_i + 16 \text{ mm}$$

Total width B_{EF}

$$B_{EF} = B_i + 19 \text{ mm}$$



The maximum cable diameter strongly depends on the bending radius and the desired cable type. Please contact us.



Replaceable glide shoes



Information on the inner distribution of the cable carrier can be found on page 56.

ET1455.030 | Dimensions · Technical Data

Pitch, inner height and chain link height

t [mm]	h _i [mm]	h _G [mm]	h _{G'} [mm]
45.5	25	36	38.5

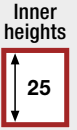

Bend radii

KR [mm]						
52	65	95	125	150	180	200



Inner/outer width and intrinsic cable carrier weight

B _i [mm]	B _k [mm]	B _{EF} [mm]	q _k [kg/m]
78	94	97	0.8

Key for abbreviations
on page 60

Order example



ET1455	·	030	·	78	·	150	·	1.456
Type		Stay variant		B _i [mm]		KR [mm]		L _k [mm]

Assembly instructions on
kabelschlepp.de/assembly

Order key
on page 58



Stay variant 040 – with lamella crossbars in the inner radius

kabelschlepp.de/
easytrax

- Weight-optimized plastic frame with particularly high torsional rigidity.
- Swivable slats on one side in any position.
- **Opening options inside:** Swivable.

Configure your cable carrier:
onlineengineer.de

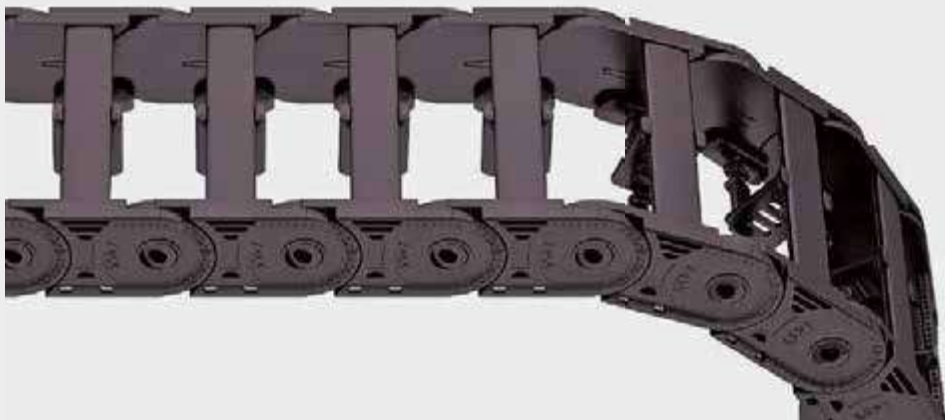

Stay arrangement on every chain link (VS)



B_i from 78 mm

Technical support:
technik@kabelschlepp.de

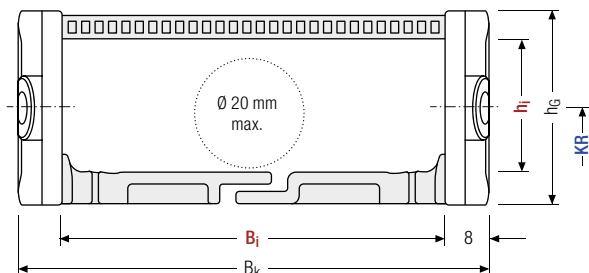

Calculating the cable carrier width

Outer width B_k

$$B_k = B_i + 16 \text{ mm}$$



The maximum cable diameter strongly depends on the bending radius and the desired cable type. Please contact us.



Design 040 is not suitable for gliding arrangement.



Pitch, inner height and chain link height

t [mm]	h _i [mm]	h _G [mm]
45.5	25	36

Inner heights



Bend radii

KR [mm]						
52	65	95	125	150	180	200

Inner widths



Inner/outer width and intrinsic cable carrier weight

B _i [mm]	B _k [mm]	B _{EF} [mm]	q _k [kg/m]
78	94	97	0.8

Key for abbreviations
on page 60

Order example



ET1455	·	040	·	78	·	150	·	1.456
Type		Stay variant		B _i [mm]		KR [mm]		L _k [mm]

Assembly instructions on
kabelschlepp.de/assembly

Order key
on page 58



Divider systems

As standard, the divider system is assembled at each 2nd chain link.

As standard, dividers and the complete divider system (dividers with height separations) can be moved in the cross section (**version A**).

The dividers are easily attached to the stay for applications with transverse acceleration and for laterally recumbent applications by simply turning them. The locking cams click into place in the locking grids in the crossbars (**version B**).

kabelschlepp.de/
easytrax

Configure your cable carrier:
onlineengineer.de

Movable divider

Version A (Standard)

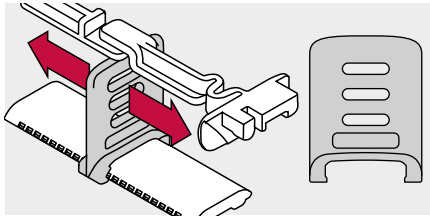

Fixable divider (2.5 mm grid)

Version B

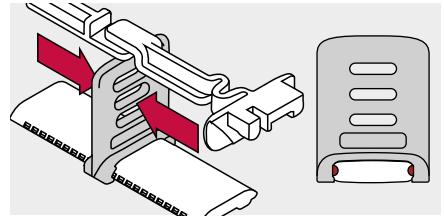

Divider system TSO without height separation

S_T [mm]	W_f [mm]	Version A			Version B			
		a_{TL}/a_{TR} min [mm]	a_x min [mm]	a_c min [mm]	a_{TL}/a_{TR} min [mm]	a_x min [mm]	a_c min [mm]	a_x Raster [mm]
2	7	3.5	7	5	4	7.5	5.5	2.5

Technical support:
technik@kabelschlepp.de

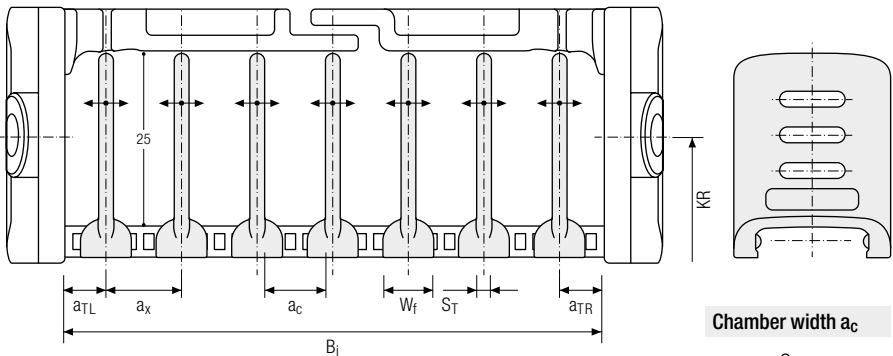

Chamber width a_c
 $a_c = a_x - S_T$

One part end connectors – plastic

The plastic end connectors can be **connected from above and below**. The connection type can be changed by reconnecting the end connector.

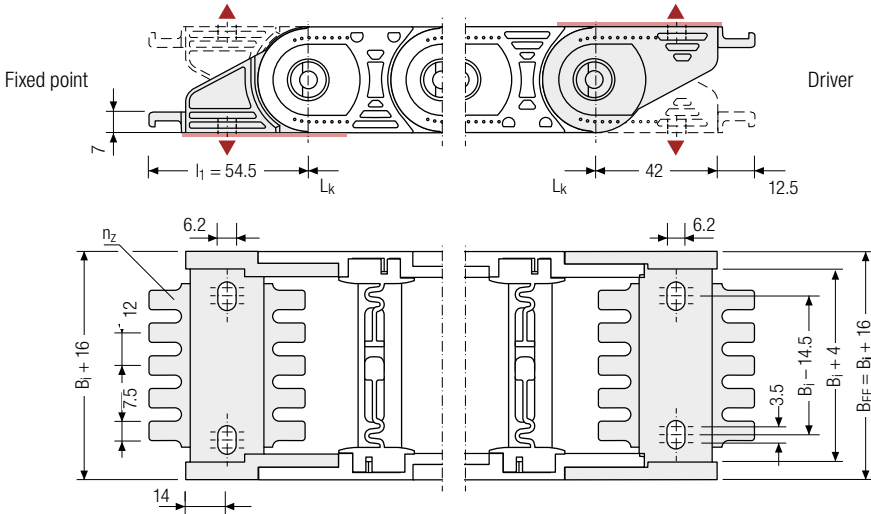

Inner heights



Inner widths



Key for abbreviations on page 60

Recommended tightening torque: 6 Nm for screws M6 - 8.8

▲ Assembly options

B_i [mm]	B_{EF} [mm]	n_z
78	94	2 x 6

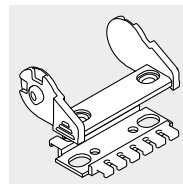

The end connectors are optionally also available **without** strain relief comb (except B_i 25). Please state when ordering.

Assembly instructions on kabelschlepp.de/assembly

Connection variants

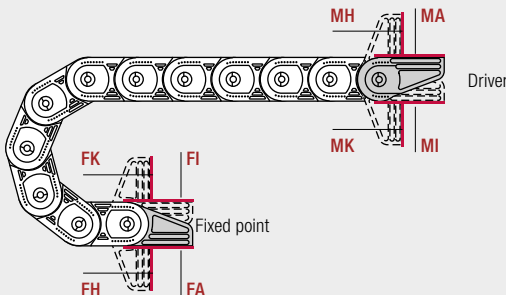

Connection point

- F – fixed point
- M – driver

Connection type

- A – threaded joint outside (standard)
- I – threaded joint inside
- H – threaded joint outside rotated by 90°
- K – threaded joint inside rotated by 90°

Order key on page 58



Order

kabelschlepp.de/
easytrax

Cable carrier

Type	Stay variant	B _i [mm]	KR [mm]	L _K [mm]
			52	
			65	
			95	
			125	
			150	
			180	
			200	
ET1455	030	78	150	1.456
ET1455	040	78	150	1.456

ET1455	030	78	150	1.456
Type	Stay variant	B _i [mm]	KR [mm]	L _K [mm]

Configure your cable carrier:
onlineengineer.de



International order specification INTOK:

Information about the International Order Key can be found in the chapter "International Order Key" from page 1.

Technical support:
technik@kabelschlepp.de

Divider system

Divider system	Version	η _T
	A	min. 2
	B	...
TS0	B	3

TS0	B	3
Divider system	Version	η _T



Please state the designation of the divider system (TS0, TS1 ...), version and number of dividers per cross section [η_T].

Connection variant

End connector	Connection point	Connection type
		A
		I
	F	H
Anschlusswinkel	M	K
Anschlusswinkel	F	A
Anschlusswinkel	M	A



Please state the desired connection variant as well as the desired strain relief type for the fixed point and for the driver.

Accessories

Single-sided strain relief combs

The optional plastic strain relief combs are assembled between the UMB end connectors and require no separate screw fixing.

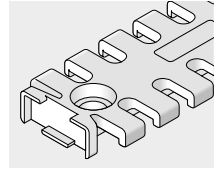

Inner heights



Inner widths



Gliding elements

The optional glide shoes ensure a substantially longer service life of the cable carrier in gliding operation.

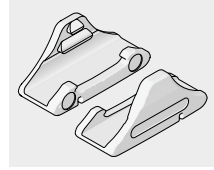
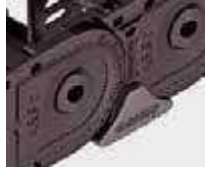

Outer dampers (Design 040)

The use of outer dampers effectively reduces uncoiling noise. Particularly recommended for support trays and guide channels.

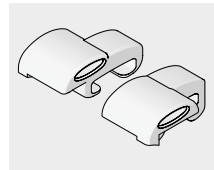

Guide channels

The cable carrier always has to be guided in a channel for gliding applications. This prevents the upper and lower run from slipping.

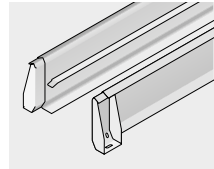

Support trays

An even surface is required for safe unrolling of the cable carrier. This is ensured by a support tray.

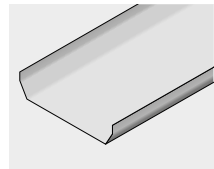

Key for abbreviations on page 60

Assembly instructions on kabelschlepp.de/assembly

Order key on page 58



General abbreviations

a_c	= nominal width inner chamber	l_{2-5}	= connection dimensions
a_{max}	= max. travel acceleration	l_A	= length of end connector
a_{TL}	= distance lateral tabs inside to center of first divider	l_B	= length of carrier in bend
a_{TR}	= distance lateral tabs inside to center of last divider	l_D	= length of permitted sag
a_x	= divider center to center distance	l_f	= unsupported length
b_1	= inner width of guide channel	l_{ES}	= length of energy conduit
b_A	= distance between connection boreholes	l_k	= cable carrier length without connection
B_{EF}	= overall width of cable carrier incl. attachments	l_S	= travel length
B_i	= inner width	l_v	= fixed point offset
B_k	= outer width	n_p	= number of hole stay inserts
B_{KA}	= outer width of guide channel	n_{RKR}	= number of RKR links
B_p	= width of hole stay inserts	n_T	= number of dividers
B_{St}	= stay width	n_Z	= number of comb teeth for strain relief
c	= distance between hole stay bores	q_k	= intrinsic cable carrier weight
d	= diameter	q_z	= additional load
D	= bore diameter	RKR	= reverse bending radius
d_R	= pipe diameter	s	= sheet metal thickness
H	= connection height	S_H	= thickness of height separation
H'	= reduced connection height	S_T	= thickness of divider
h_G	= chain link height	t	= pitch
$h_{G'}$	= chain link height incl. glide shoe	U_B	= loop overhang
h_i	= inner height	VD	= position of continuous height separations in divider
H_i	= inner height of frame stay assembly	VR	= position of partial height separations in divider
h_{KA}	= outer height of guide channel	v_{max}	= max. travel speed
HS	= half-stayed	VS	= fully-stayed
H_z	= installation height	W_f	= base width of divider
KR	= bending radius	z	= pretension
l_1	= connection length		

Definitions

Driver view = view into the driver connection

Pictographs

	inner height		stay arrangement on every 2 nd chain link		clean room suitable
	inner width		stay arrangement on every chain link		quiet running/low noise
	inner width (B _i) in x mm increments		cannot be opened		sold by the meter
	pitch		opens outward		ESD material
	bending radius		opens inward		suitable for explosive atmospheres
	long travel length		opens inward/outward		heat-resistant
	travel length unsupported		covered cable carrier		cold-resistant
	travel length gliding		sliding dividers		resistant to hot chips
	high additional load		fixable dividers		flame-resistant V0 (UL94)
	high travel acceleration		fixable dividers in x mm grid		flame-resistant V2 (UL94)
	high travel velocity		height separation possible		order code
			height separation in 1 mm increments		important information
			guide channel required		
			strain relief		

Inner heights

 4.6
 25

Inner widths

 7
 78

Key for abbreviations
 on page 60

Assembly instructions on
kabelschlepp.de/assembly