

# KABELSCHLEPP

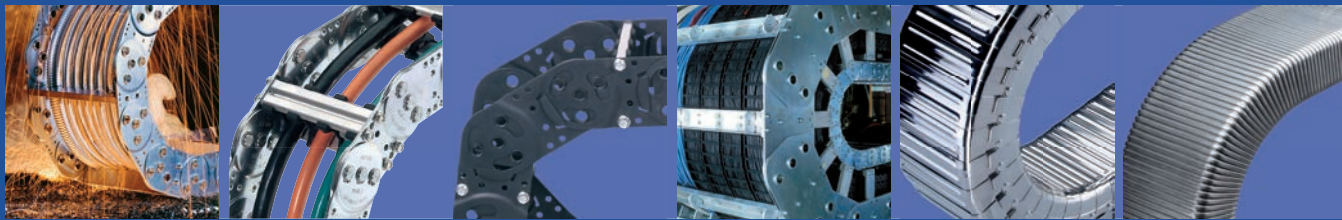

## STEEL CABLE CARRIERS

ROBUST  
HEAT RESISTANT  
LONG SERVICE LIFE

EDITION  
**10-2013**



# Energy needs guidance.

Pioneering innovation makes it possible.

TSUBAKI KABELSCHLEPP invented the steel cable carriers 60 years ago. A world market has developed for our idea – and the inventor has become one of the companies which gives new impulses to the market world wide by means of innovative solutions.

## The original from the inventor – 60 years of experience

Our steel cable carriers are impressive due to functionality, long service life, fitting accuracy and variety. Benefit from our decades of experience and innovation strength. Our service includes all facets of constructive advice, technical design up to the delivery of complete solutions.

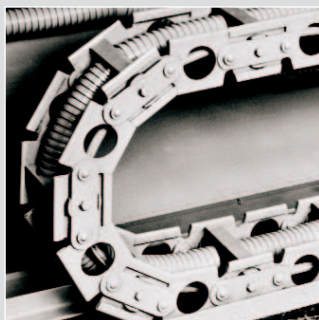

■ TSUBAKI KABELSCHLEPP steel cable carrier on a plano-milling machine, 1955

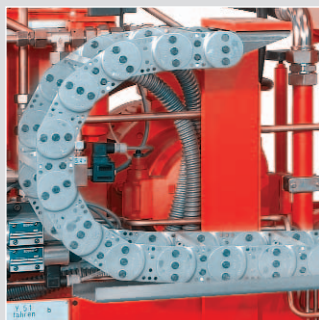

■ Steel cable carrier on a scissored coil lift

## KABELSCHLEPP + TSUBAKI = MORE

TSUBAKI KABELSCHLEPP is now integrated into the Tsubaki Group and made responsible for managing the worldwide cable carrier systems business. For more than 40 years, both companies have been close cooperative partners. With this integration, we will leverage our successful business relationship in one strategic enterprise.



■ The group of companies' headquarters in Gerlingen. This is where worldwide experience and know-how come together.



### Service that you can rely on

Our service team takes over the planning and execution of the assembly of cable carrier systems even with difficult assembly conditions.

- complete mounting with a guide channel
- uncoiling for long travel lengths
- assembly at significant heights (e. g. crane systems)

The specialists of our service center provide you with the support that you need. You will see: With TSUBAKI KABELSCHLEPP, you make a decision in favour not only of a cable carrier, but of a totally harmonised system.



■ KABELSCHLEPP Service Center Hünsborn.

### TOTALTRAX Complete Systems – everything from a single source

From our expertise in the area of cable carriers, you can also benefit in respect of other related things: Our TRAXLINE – Calbes for Motion are highly flexible cables that satisfy particularly stringent quality requirements.

And our TOTALTRAX system goes one step further: We supply you with complete cable and hose carrier systems, including the chain, cables, plugs and connectors, all ready-to-install. The complete cable carrier system will be supplied to you "just-in-time" and ready to install.



■ Complete TOTALTRAX cable and hose carrier system with chain, cables, plugs and connectors, pre-mounted on a shipping crate.

Table of abbreviations on the back side,  
please open up.



Do stop by our page on the internet:  
**kabelschlepp.de**

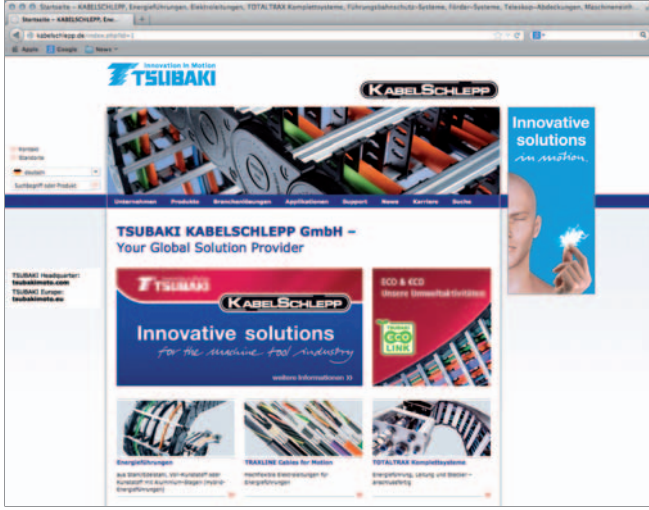

## General abbreviations

$a_T$	= Distance from the inside edge of the end piece/ end divider to the centre of the first/last divider
$a_x$	= Centre-to-centre spacing of dividers
$B_{EF}$	= Width of the cable carrier including glide shoes
$B_i$	= Cavity width inside the carrier cross-section
$B_k$	= Width of cable carrier
$B_{St}$	= Width of hole stays
$B_A$	= Width of the support tray
$B_{KA}$	= Width of the guide channel
$b_1$	= Clearance inside width of the support tray
$c$	= Distance between the holes (for hole stays)
$d$	= Cable or hose diameter
$D$	= Hole diameter in hole stay
$H$	= Connection mounting height
$H_z$	= Installation height (required clear height)
$h_A$	= Height of the support tray
$h_G$	= Chain link height
$h_i$	= Clearance height inside the carrier cross-section
$h_{KA}$	= Height of the guide channel
$h_1$	= Outlet height of the upper trough in the guide channel
$KR$	= Bending radius of the cable carrier
$L_A$	= Length of the support tray
$L_B$	= Length of the loop at the bend
$L_f$	= Unsupported length
$L_k$	= Length of the cable carrier (without connection)
$L_{KA}$	= Length of the guide channel
$L_S$	= Maximum length of the travel length
$L_V$	= Longitudinal offsets between cable carrier fixed point and centre of the travel length
$L_Z$	= Channel allowance dimension
$l_1$	= Connection dimensions
$n_T$	= Number of dividers per cross-section
$q_{EF}$	= Total weight of the carrier per metre $q_{EF} = \text{Intrinsic carrier weight } q_k +$ additional load $q_z$
$q_k$	= Intrinsic carrier weight per metre
$q_z$	= Additional load/m of cable carrier
$R_{KR}$	= Reverse bending radius
$s$	= Sheet metal thickness
$ST$	= Divider thickness
$ST_A$	= Divider thickness for mounting frame stay
$t$	= Pitch
$\ddot{U}_B$	= Loop overhang (Depot)
$X$	= Distance between the fixed points (in an opposing arrangement)
$z$	= Pre-tension on the cable carrier

Access our 2D and 3D data on the internet.

# Reduce your design time.

Accelerate your design processes with our 2D and 3D models from the CAD component libraries. New product data has been added to the **CADENAS** and **TRACEPARTS** component libraries.

Download all product data from both libraries for free. Native data and all conventional export formats are available for all conventional CAD systems.

More information:  
kabelschlepp.de

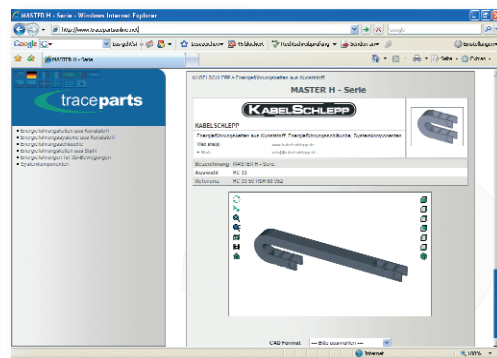

## CADENAS

- Easy to connect to PDM and ERP systems
- The PARTSolutions catalogue can be easily accessed using a button in the Autodesk Inventor
- Detailed cable carrier models available

## TRACEPARTS

- Most TSUBAKI KABELSCHLEPP cable carriers are available
- Worldwide, the only CAD library with "CAA" (CATIA) partner status
- Also available on a free CD – contact us to obtain it

TRAXLINE cable database for EPLAN.

# TSUBAKI KABELSCHLEPP and EPLAN.

EPLAN has developed over more than 20 years into a leading E-CAD system and has become more or less established as a standard in some branches.

As a provider of continuous bending highly flexible electrical cables for cable and hose carriers, we offer you the TSUBAKI KABELSCHLEPP TRAXLINE cable databases as a superior tool for optimising your daily work with EPLAN.

The databases are optimized for use in EPLAN5 and for transmission according to EPLAN P8 electric.

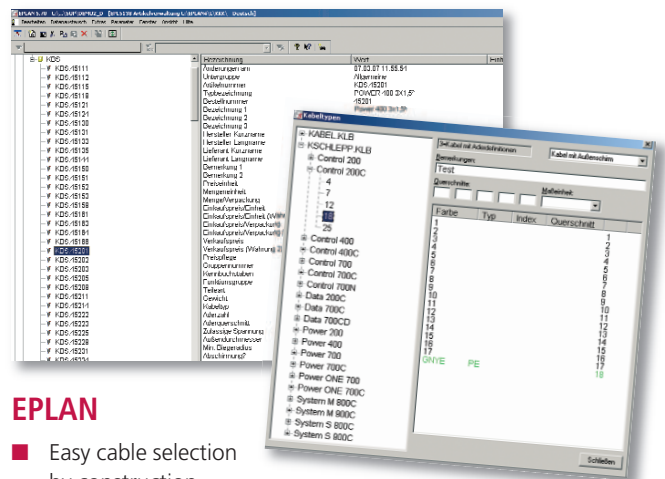

## EPLAN

- Easy cable selection by construction
- Automatic addition of core number, cross-section and core colour
- Complete data for parts lists and other evaluations

# With just a few clicks of the mouse to an optimal TSUBAKI KABELSCHLEPP cable carrier system

## Online cable carrier configuration tool OnlineEngineer

Using the **OnlineEngineer** you can **quickly, dependably and flexibly** design the TSUBAKI KABELSCHLEPP cable carrier system with the optimal price/performance ratio!

## Laying out your cable carrier system with the OnlineEngineer.

Just input the parameters of your application and the OnlineEngineer will **automatically calculate** the TSUBAKI KABELSCHLEPP cable carrier system with the **optimal price/performance ratio!** Alternatively you can follow the **step-by-step** menus and individually design your desired cable carrier system. If you already know which TSUBAKI KABELSCHLEPP cable carrier system you would like to employ just enter the order specifications and you will receive all applicable information by mouse click.

The distribution of the cables within a chain crosssection can also be defined easily. With the click of the mouse you'll receive a to-scale **diagram in CAD format.** Any and all functions can be combined so that it will only be necessary for you to enter the required information once and so that you can remain flexible in your design. As soon as you have laid out your cable carrier you can **download** a corresponding **2D diagram or a 3D model.**

**OnlineEngineer.de**  
TSUBAKI KABELSCHLEPP  
Cable Carrier Configurator



**KABELSCHLEPP**  
TSUBAKI KABELSCHLEPP  
OnlineEngineer.de  
TSUBAKI KABELSCHLEPP  
Energieführungs-Konfigurator

Startpage Kabelschlepp Website Imprint

**TSUBAKI KABELSCHLEPP OnlineEngineer - The specification tool for cable carrier system**

Online Engineer allows you to configure the appropriate KABELSCHLEPP cable carrier for your specific application. As registered user you have access to all functions. With a guest login you can select and configure cable carrier chains too. If you prefer to work with the current version of the OnlineEngineer, please click [here](#).

**Dimensions & application parameters**

Quantity: 1  
Chain length Lk: to be calculated

Orientation: horizontal

Horizontal travel length Ls: 0 mm  
Fixed point offset Lv: 0 mm

Weight of cables cz: 0 kg/m  
Velocity v: 1 m/s  
Acceleration a: 1 m/s<sup>2</sup>

Inside width Bi: 0 mm  
Round up to standard Bi:   
Inside height Hi: 0 mm  
Min. bending radius KR: 0 mm  
Round down (max. 5 %) to standard KR:

Login  
Create user account  
Start new configuration  
Quote Request  
Load data

### OnlineEngineer

- economical due to optimal price/performance ratio in the design of TSUBAKI KABELSCHLEPP cable carrier system
- time savings through automatic layout function
- transparency: all information of the cable carrier system is displayed as a glance
- efficiency through linking with 2D & 3D data for download
- online price inquiry to TSUBAKI KABELSCHLEPP

# Contents

## Copyright

Illustrations and text in this catalog are purely informative and, in part, only exemplary. They do not represent any quality guarantee and do not assure suitability for a particular application. This catalog is subject to technical and optical changes. Orders to be placed in the future are subject to the legally agreed quality of the relevant product, or otherwise the quality of each product as it was at the time of the signing of the contract.

All rights of this catalog are reserved, including text and illustrations, as well as brand names and corporate logos/trademarks used, in particular the rights of photocopying, distribution, translation or any other form of editing as well as the right of public reproduction.

No part of this catalog, including brand names and corporate logos/trademarks may be reproduced, processed, photocopied or distributed in any form or by any means, especially optical, photo-mechanical, paper-based or electronic, without prior written permission of TSUBAKI KABELSCHLEPP GmbH.

Except hereof is the legally authorized use of photo-copying for merely private purposes (paragraph 53 German copyright law).

Our current terms and conditions of sales and delivery can be found at [kabelschlepp.de](http://kabelschlepp.de)

© 2013 · TSUBAKI KABELSCHLEPP GmbH

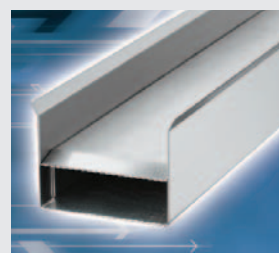
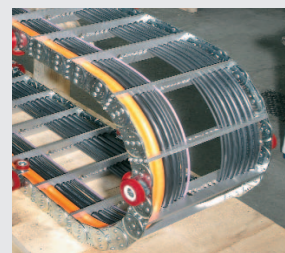
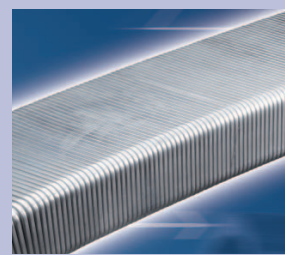
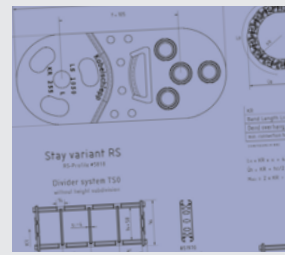



## Steel Cable Carriers/ Design guidelines

Information for the design  
of steel cable carriers

	page
Steel cable carriers	10
Guideline for fast product selection	16
Design guidelines	25
Laying guidelines for cables	49
Material properties	54

## LS/LSX Series

Light, economically priced steel cable carriers

	page
Type LS/LSX 1050	61

## S/SX Series

Extremely robust steel cable carriers

	page
Type S/SX 0650	77
Type S/SX 0950	89
Type S/SX 1250	101
Type S/SX 1800	121
Type S/SX 2500	131
Type S/SX 3200	137
Type S/SX 5000/6000/7000	143

## CONDUFLEX / MOBIFLEX

Closed tubes

	page
CONDUFLEX	
Designer cable carrier	150
MOBIFLEX	
Tube	154

## TRAXLINE Cables for Motion

Continuous bending hi-flex electrical cables for cable carriers

	page
TRAXLINE	
Cables for Motion	158
TOTALTRAX	
Complete Systems	162

## TOTALTRAX

Complete Systems

## Accessories

The extensive range of accessories provides  
the appropriate solution for every application.

	page
Support trays/Guide channels	166
Support rollers	170
Steel band covers	172
Strain relief devices	173
Fax question form	180
Information request	181

## Application examples

Steel cable carriers in use in various applications

	page
Application examples	183



# STEEL-LINE – Steel Cable Carriers.

Solutions for extreme applications.

## Robust construction for strong mechanical loads

Due to their design and the use of high quality materials, our steel carriers can cope with the harshest loads.

Steel carriers also guarantee reliable operation in the case of serious contamination and external mechanical influences – expensive downtimes are avoided.

### Examples of application areas:

steel works, foundries, drilling equipment, coal excavators, construction equipment, oil rigs, lifting vehicles, telescopic lifting equipment



## High additional loads and large unsupported lengths

The high strength of the steel material makes possible significantly larger unsupported lengths for the same dimensions and additional loads than for plastic carriers.

**Examples of application areas:** plant construction, tool changers, telescopic lifting equipment

### ■ small dimensions

**inner dimensions:**

31 x 65 mm

**system weight:**

up to 30 kg/m

**unsupported**

**chain length:**

up to 3 m

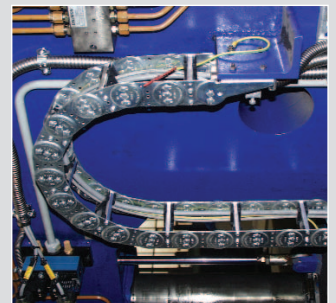

### ■ large dimensions

**inner dimensions:**

370 x 1800 mm

**system weight:**

up to 600 kg/m

**unsupported**

**chain length:**

more than 12 m



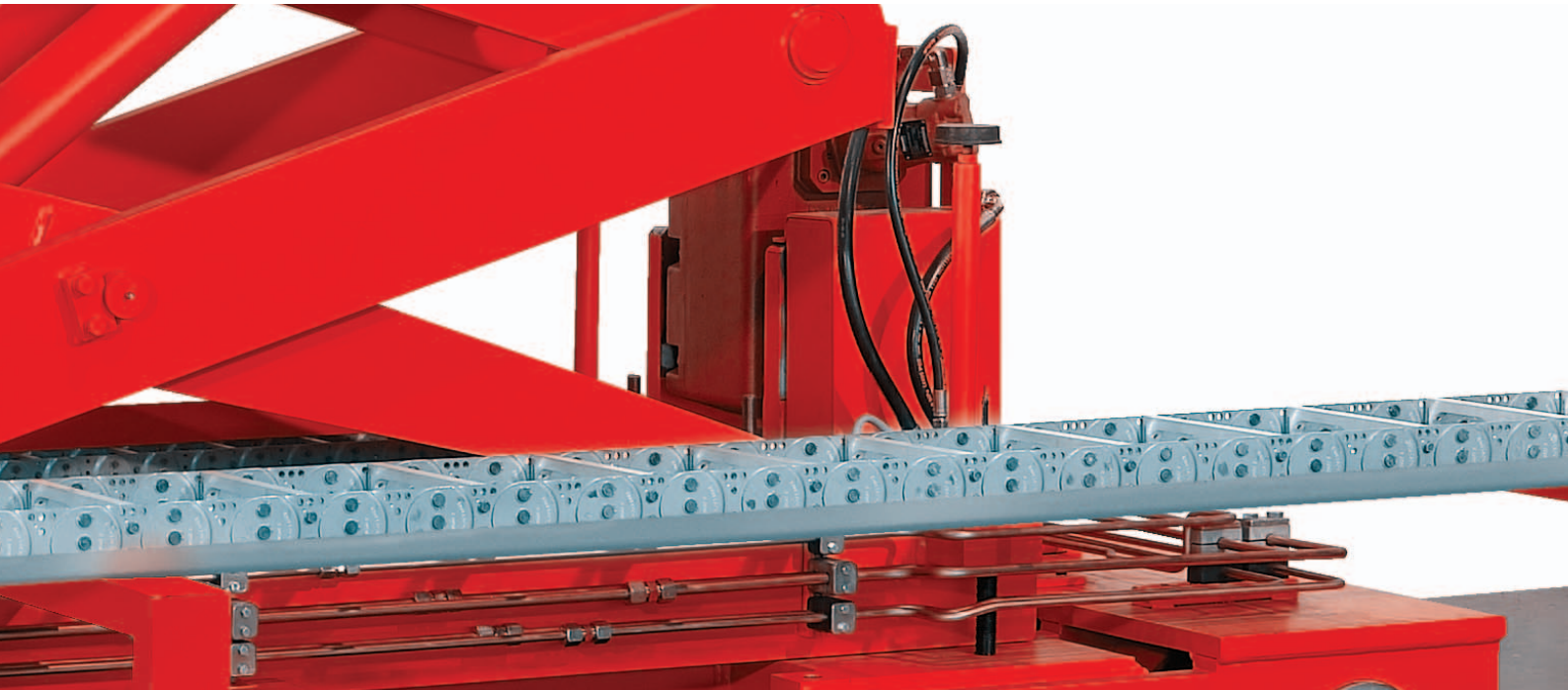

### Heat resistance

- constant temperature loads up to 600 °C\* (depending on stay and chain band design) are possible
- short-term up to 1000 °C\* (SX version)
- hot chips, hot cast parts, forgings and molded parts
- high radiant heat

\* maximum values, application dependent

### Examples of application areas:

foundries, steel works, rolling mills, industrial furnaces

### Extreme, particular environmental influences

- sea water resistant
- radiation resistant
- UV resistant
- chemical-resistant

### Examples of application areas:

port facilities, offshore use, nuclear power stations, any outdoor use, waste disposal companies



# LS/LSX Series.

Cost-effective steel chains with light design.



LS 1050  
at least  
**20% less expensive**  
than S 0950 with stay variant RS

LS/LSX  
**Weight**  
optimized - 40%



**STEEL**  
SPECIAL COATED

**STAINLESS  
STEEL**  
RUST-FREE

## LS/LSX series – light, economically priced steel chains.

The chains are very light and yet very stable due to the weight-optimized link plate design. The unsupported length for the LS series is significantly higher as compare with plastic chains of the same size.

- economically priced, light steel chains
- improved dynamic characteristic values due to weight-optimized design
- large unsupported lengths for small to medium additional loads
- available in 1 mm section width
- cover with steel band for protection of the cables available on request

LS/LSX steel chains can be found starting on page 58.

Design of steel cable carriers – page 26.

### Light sidebands without additional bolts

Special coating or stainless steel



### Optional: central bolt and locking ring

For applications involving large loads



### Optional C-Rail for strain relief elements fixed in the connection



### TIP: Design service

Our system consultants would be happy to carry out the design of your cable and hose carrier system for you – free of charge, competently and quickly. Please contact us.

# S/SX Series.

Extremely robust steel chains in 9 different types.



**STEEL**  
ZINC-PLATED

**STAINLESS  
STEEL**  
RUST-FREE

**S/SX series – extremely robust and stable steel chains for heavy mechanical loads and harsh environmental conditions.**

Steel cable carriers proven over many years with extremely stable chain link plates and a link design with multiple stop system and special bolts. Large unsupported lengths and high additional loads are possible due to the extremely stable design.

- extremely robust, stable steel chains for heavy mechanical loads and harsh environmental conditions
- very large unsupported lengths also for large additional loads
- available in 1 mm section width
- different types with different dimensions are available
- covers with aluminium cover systems and steel band are possible for protecting the cables

**S/SX steel chains can be found starting on page 74.**

**Design of steel cable carriers – page 26.**

**TIP: Design service**

Our system consultants would be happy to carry out the design of your cable and hose carrier system for you – free of charge, competently and quickly. Please contact us.

Also available as covered variants with cover system or steel band covering.



**Cover systems – RMD stay variant.**

**Robust cover also for heavy mechanical loads.**

See RMD stay variant within the types.



**Steel band covers – economically priced, light cover variant for flying sparks and small chips.**

See the Accessories chapter, page 165.

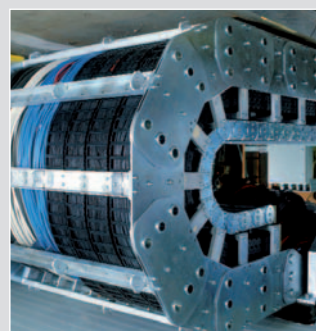

# CONDUFLEX.

Closed designer cable carrier.



## CONDUFLEX Designer TUBES

- Enclosed cable carriers in a sophisticated design
- Attractive appearance owing to high-grade steel brackets and fiberglass reinforced polyamide frame
- Optimized protection for cables and hoses

CONDUFLEX Designer TUBES  
can be found starting on page 149.

# MOBIFLEX.

Flexible metal helical tube.



## MOBIFLEX TUBES

- Enclosed cable carriers with flexible metal helical tubes
- Unsupported thanks to the inserted, pre-tensioned steel band. Ideal in case of hot metal chips.

MOBIFLEX TUBES  
can be found starting on page 154.

### TIP: Design service

Our system consultants would be happy to carry out the design of your cable and hose carrier system for you – free of charge, competently and quickly. Please contact us.

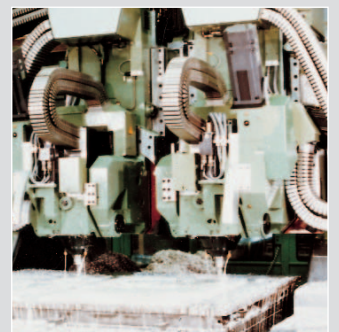
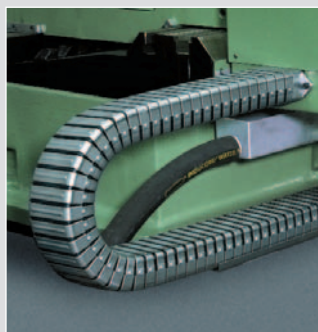
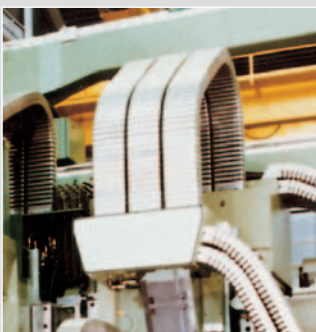

## TOTALTRAX.

Complete systems.



### TOTALTRAX – completely pre-assembled cable carrier systems

One supplier and one contact person for the complete system. We take over the planning and project planning and the procurement of all components for your cable carrier system.

- Consulting
- Project planning
- Design
- Complete delivery
- Electrical cables
- Connectors
- Retaining plates
- Complete assembly of all components

TOTALTRAX Complete systems can be found starting on page 162.



## TRAXLINE.

Highly flexible electrical cables.



TSUBAKI KABELSCHLEPP  
TRAXLINE  
cables for  
cable carriers

### TRAXLINE Cable for Motion – highly flexible electrical cables

The successful TSUBAKI KABELSCHLEPP TRAXLINE range is constantly expanded and optimized as an innovative standard range of modern cable carrier cables specially for use in cable carriers.

### TRAXLINE Cable for Motion – an overview can be found starting on page 157.

Or simply request our catalogue "TRAXLINE Cable for Motion".



# Guideline for fast product selection.

please open up

Product Symbol	Product	Type	Clearance height <sup>A)</sup> h <sub>i</sub> in mm	Carrier width <sup>A)</sup> B <sub>k</sub> in mm		Bend radii in mm		Travel length <sup>D)</sup> L <sub>S</sub> in m	Dynamics for unsupported arrangement		Variants of carrier/hose cross-section (Stay variants – see page 24)										Cover with spring steel strip possible	Technical data see page	Type				
				from	to	min.	max.		Travel speed <sup>C)</sup> v <sub>max</sub> in m/s	Travel acceleration a <sub>max</sub> in m/s <sup>2</sup>	Closed frame	Frame stay RS 2	Frame stay RS 1	Frame stay RV	Frame stay RM	Frame stay RMA	Frame stay RMR	Tube stay RR	Hole stay LG	Frame stay RMD							
	Light cable carriers with chain bands made of steel <sup>β)</sup>	LS/LSX 1050	58	100	600	105	430	10.0	2.5	10.0				■			■							on request	61	LS/LSX 1050	
	Cable carriers with chain bands made of steel <sup>β)</sup>	S/SX 0650	31	70	500	75	400	6.0	2.5	5.0				■			■								77	S/SX 0650	
		S/SX 0950	46	125	600	125	600	9.0	2.5	5.0				■			■				▲				89	S/SX 0950	
		S/SX 1250	72	130	800	145	1000	12.0	2.5	5.0				■			■				▲				101	S/SX 1250	
		S/SX 1800	108	180	1000	265	1405	18.0	2.0	3.0				■			■				▲				121	S/SX 1800	
		S/SX 2500	183	250	1200	365	1395	24.0	2.0	3.0				■			■				▲				131	S/SX 2500	
		S/SX 3200	220	250	1500	470	1785	25.0	2.0	2.5							■				▲				137	S/SX 3200	
		S/SX 5000	150	150	1000	500	1200	12.0	2.0	3.0							■				●				143	S/SX 5000	
		S/SX 6000	240	200	1200	700	1500	18.0	1.5	2.0							■				●				143	S/SX 6000	
		S/SX 7000	370	300	1500	1100	2400	25.0	1.0	1.0							■				●				143	S/SX 7000	
	CONDUFLEX	CF 055	25	–	45	65	150	3.0	10.0	20.0	■													■ <sup>E)</sup>	150	CF 055	
		CF 060	40	–	36	–	100	3.5	10.0	20.0	■														150	CF 060	
		CF 085	38	–	73	100	250	4.5	8.0	18.0	■														■ <sup>E)</sup>	150	CF 085
		CF 115	52	–	102	140	300	5.0	8.0	16.0	■														■ <sup>E)</sup>	150	CF 115
		CF 120	70	–	100	155	200	5.5	6.0	15.0	■															150	CF 120
		CF 175	72	–	162	185	350	6.0	6.0	12.0	■															■ <sup>E)</sup>	150
	MOBIFLEX	MF 030	24	–	26	–	80	3.0	10.0	20.0	■															154	MF 030
		MF 050	44	–	45	75	200	3.0	10.0	20.0	■															154	MF 050
		MF 080	78	–	80	100	200	4.0	10.0	18.0	■															154	MF 080
		MF 110	108	–	109	150	300	4.0	6.0	15.0	■															154	MF 110
		MF 170	167	–	170	190	365	5.0	6.0	12.0	■															154	MF 170

- Reference:
- Standard
  - ▲ Customized standard products
  - Special order as per customer specifications

**Stay variants / stay designs:**  
(Detailed information starting on page 28)

**RS – frame stay, narrow version**  
Variant RS 1 – with quick-release aluminium stays on the outside or inside  
Variant RS 2 – with bolted aluminium stays

**RV – frame stay, reinforced version**  
Aluminium stays on the inside and outside bolted to the chain bands – high stiffness

**RM – frame stay, solid version**  
Aluminium stays bolted on both sides – greatest stability, for maximum stay widths

**RMR – roller stay system**  
Aluminium stays bolted on both sides – with plastic roller system

**RMD – frame stay, cover system – covered cable carrier**  
Aluminium cover bolted on both the inside and outside to the chain bands

**RMA – mounting frame stay**  
Stay variant for large cable diameter

**RR – frame stay, tube version**  
Steel axles as connecting profiles with rotating metal tubes

**LG – hole stay – split design**  
Aluminium stays – order-specific production – maximum degree of operating reliability

- <sup>A)</sup> dependent on the stay variant
- <sup>B)</sup> multi-band chains for larger widths possible
- <sup>C)</sup> values for S and LS versions; values for SX / LSX versions reduced by 0.5 m/s
- <sup>D)</sup> values for S and LS versions; see load diagram of the respective type for values for SX versions
- <sup>E)</sup> cover with protective straps possible



## Plastic cable carriers – the other cable carrier range



BASIC-LINE

### BASIC-LINE Solid plastic cable carriers with fixed chain widths

- economically priced for standard applications
- many types available immediately ex-stock world wide

#### MONO-Serie

Cable carriers with simple design for standard applications.

- Single unit chain links with the option of either fixed or openable brackets
- Simple and quick assembly
- End connector with integrated strain relief

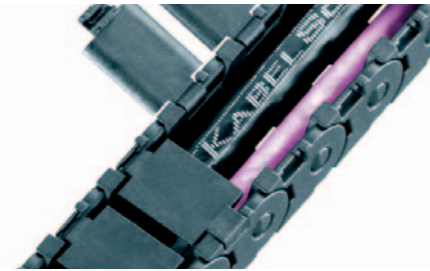

#### QuickTrax-Serie

Compact and cost-effective cable carriers in two-component technology.

- Quick and easy to open
- Crossbars in opened condition also non-switched with the chain link
- Stable chain construction
- Designs with inward or outward opening crossbars
- Long unsupported lengths



#### UNIFLEX Advanced

Light, quiet all-rounder with wide range of applications.

- Noise-optimized for quiet operation
- Inward or outward opening or single unit
- Clamp system for fast opening
- Movable or fixed dividers
- Long unsupported lengths
- Many separation options for the cable

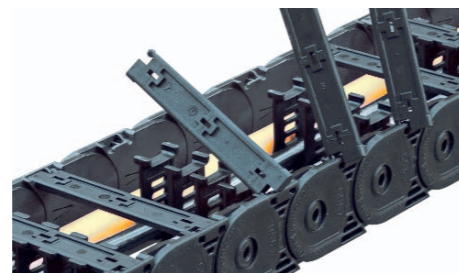

#### UNIFLEX Series

Proven cable carriers with many opening and cover variants.

- Openable either inwards or outwards according to design
- Robust, double stroke system for long unsupported length
- Particularly high torsional rigidity
- Open, half-covered and completely covered designs
- Many separation options for the cables



BASIC-LINE

### TKP35

Robust all-rounder with variable subdivision.

- Robust and extremely rigid stroke system for extensive unsupported sections
- Quiet operation due to internal dampening system
- Interior without sharp edges, design that protects the cable
- Vertical moveable dividers or with locking cams, can be attached at 2-mm increments\*
- Easy to open versions, left or right

\* not Bj 16



### BASIC-LINEPLUS Solid plastic cable carriers with fixed chain widths

- Fast laying by simply pressing in the cables
- Ideal for short travel paths and high travel speeds

#### EasyTrax Series

Extremely quick cable laying, extra-stable thanks to two-component technology.

- Very fast cable laying by simply pressing in
- Very high utilization factor due to flexible crossbars swivelling in the direction of the carrier and not in the cable space
- Stable chain construction
- Extensive unsupported length
- Very quiet thanks to integrated noise damping system
- High travel speed possible

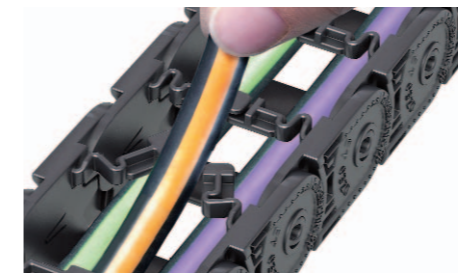

BASIC-LINEPLUS

#### PROTUM Series

Small, light cable carrier for unsupported applications.

- Very long life – no hinges and hence no hinge wear
- Very good ratio of usable space to outer dimensions
- Low vibration and quiet operation
- Optimum for short travel lengths and high travel speeds

**PROTUM Office:** Flexible cable carrier for office and workshop furniture



#### TKZP

Low-wear, design made from extruded profiles.

- Easy cable routing due to folding structure
- Easy adaptation to the chain length
- Low weight, good ratio between interior and exterior width
- Quiet operation due to short partition and extruded profile
- Low dust generation, because there is no friction between the chain links
- Flexible, also for side movement



VARIO-LINE

### VARIO-LINE Cable carriers with variable chain widths

- Inside and outside easy and quick to open
- Aluminum stays in 1 mm width sections are available
- Aluminum or plastic stays
- Light, robust or link-free series – a suitable solution for every application

#### K Series

Cost-effective, robust cable carrier also suitable for large additional loads.

- Robust, simple construction, even with large additional loads
- Optional glide discs for applications where the carrier is rotated through 90°
- Injection molded glide runners



#### MASTER Series

Quiet and weight-optimized cable carriers.

- Light design with weight-optimized sideband construction
- Excellent relationship between inside and outside height
- Customized bend radii can be supplied



#### M Series

Multivariable cable carrier with extensive accessories and stay variants.

- The robust all-rounder, various separation options, large selection of stay systems
- Ideal for fast, gliding applications: Replaceable glide shoes made of highly wear-resistant special plastic



#### TKP91

Easy to assemble, stable cable carriers with variable dimensions.

- Robust, even with large additional loads
- Various separation options
- Replaceable glide shoes made of highly wear-resistant special plastic with very low friction coefficient for gliding applications



LS/LSX Series

S/SX Series

CONDUFLEX  
MOBIFLEX

TRAXLINE  
TOTALTRAX

Accessories

Application  
Examples

## Plastic cable carriers – the other cable carrier range.

### XL Series

#### Cable carrier with large inside height.

- Large dimensions for cables with large cable diameter
- For unsupported and gliding applications
- Replaceable glide shoes made of highly wear-resistant special plastic

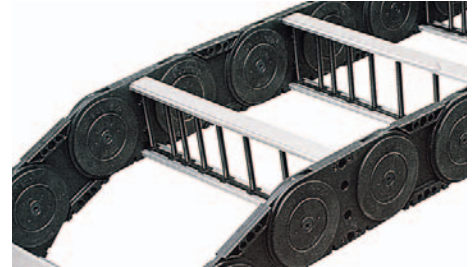

### QUANTUM

#### Light, quiet, low-vibration for high speeds and accelerations.

- Suitable for clean rooms: Clean room certification "Class 1" possible – no hinges, no link wear\*\*
- Extremely quiet, 31 db (A)\*
- For high accelerations up to 300 m/s<sup>2</sup>
- For travel speeds up to 40 m/s
- Long service life – no link wear at pin-hole joints
- Flexible design for 3D movements: the driver connection can move sideways and can be turned through up to ± 30 degrees
- Link-free: extruded sidebands

\* Tested: Q060.100.100 by TÜV Rheinland. The measurement area sound pressure level was measured at a distance of 0.5 m for uniform and jerky movement.

\*\* Tested: Q040.77.RE-70-1000 by the Fraunhofer Institute, travel speed V1 = 0.2 m/s and V2 = 0.9 m/s



### TKR

#### Extremely quiet and low-vibration for highly dynamic applications.

- Extremely quiet and low-vibration operation
- Long service life
- Ideal for highly dynamic applications
- High lateral stability
- Suitable for clean rooms
- Can be open on the inside and outside easily and quickly
- Simple shortening and extension due to modular design





## TUBE-SERIES Covered cable carriers

Covered types with plastic or aluminum cover system as well as completely closed cable carriers · Protection of the cables for applications where chips or severe contamination occur

### TKA Series

#### Chip-tight right to the end.

- Impermeable against chips, excellent cable protection also in the connector area
- TKA55: IP54 tested and verified (TÜV NORD)
- Quick routing of the cable, easy to open
- Versions available opening inwards and outwards
- Extensive unsupported sections due to 3-fold stroke system
- Integrated sliding surfaces for sliding applications
- Suppressed against vibration and noise using an internal damping system
- High torsion rigidity



### CoverTrax

#### Extreme cable protection in harsh environmental conditions.

- Solid plastic
- Outstanding protection of the cables
- Large unsupported length
- For unsupported and gliding arrangements
- Various or fixed divider systems
- Integrated strain relief devices possible in the UMB-connection
- Very quiet thanks to internal noise damping system

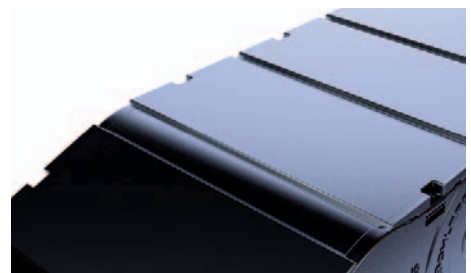

### UNIFLEX TUBES

#### Proven solid cable carriers with fixed carrier width.

- Solid plastic
- Easy to open
- Robust, double stroke system for long unsupported lengths
- Particularly high torsional rigidity
- End connectors with integrated strain relief
- Economically priced standard types



### MASTER TUBES

#### Quiet and weight-optimized cable carriers.

- Extremely quiet due to internal noise damping system
- Favorable ratio of inner to outer dimensions
- Standard bend radii, application-specific intermediate radii on request
- Variable pretension for many different applications possible
- Can be opened quickly on the inside and outside for cable laying
- Wide range of options for internal subdivision



LS/LSX Series

S/SX Series

CONDUFLEX  
MOBIFLEX

TRAXLINE  
TOTALTRAX

Accessories

Application  
Examples

## Plastic cable carriers – the other cable carrier range.

### MT Series

**Multivariable cable carrier with extensive accessories.**

- Aluminum cover system or plastic cover system available
- Can be opened quickly on the inside and the outside for cable laying
- Extremely robust due to stable plate construction
- Enclosed stroke system not sensitive to dirt/contamination
- Many possibilities of inner subdivision
- Highly wear-resistant, replaceable glide shoes available

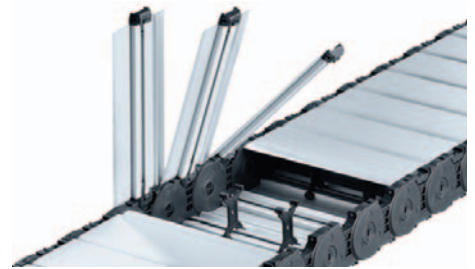

### TKC91

**Easy to assemble, stable cable carriers with variable dimensions.**

- Robust, even with large additional loads
- Various separation options
- Replaceable glide shoes made of highly wear-resistant special plastic with very low friction coefficient for gliding applications



## 3D-LINE Cable carriers for 3D-movements

### ROBOTRAX System

**Cable carriers for 3D movements.**

- For three-dimensional movements
- Can be deployed on robots for swiveling and rotational movements: The same system for robot feet and arms
- Open design
  - Fast cable laying by simple pressing in of the cables – no threading through is necessary
  - Simple inspection of all the cables
- Optimum system for long service life of the cables:
  - The minimum bend radius can be maintained
  - The cables are cleanly isolated in three separate chambers
- Special plastic for long service life
- With channel system, it is a universal solution for rotary applications such as rotary tables and assembly equipment



Steel cable carriers

# Design Guidelines

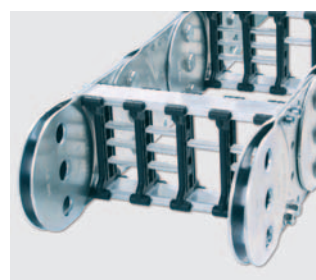

	page
<b>Carrier construction</b>	
– Design of steel cable carriers	26
– Internal subdivision of the carrier cross section, cable guidance/divider systems	27
<b>Stay variants</b>	28
<b>Design of the cable carrier</b>	
– Inner dimensions, bend radius	30
– Chain length, support	31
– Chain cover, connection mounting height, pre-tension	32
– Connection variants	33
<b>Overview of installation variants</b>	34
<b>Laying guidelines for cables and hoses</b>	49
<b>Strain relief of cables and hoses</b>	52
<b>Long service life of the cables</b>	53
<b>Material specifications of cable carriers</b>	54
<b>Environmental conditions</b>	56

LS/LSX Series

S/SX Series

CONDUFLEX  
MOBIFLEX

TRAXLINE  
TOTALTRAX

Accessories

Application  
Examples

# Carrier construction.

## Design of steel cable carriers.

KABELSCHLEPP cable carriers made of steel consist of two or more parallel running chain bands made of high quality, specially coated, galvanized or rust and acid resistant steel. The chain bands are connected using variable width stays and this forms the cable space.

### Carrier construction LS/LSX Series

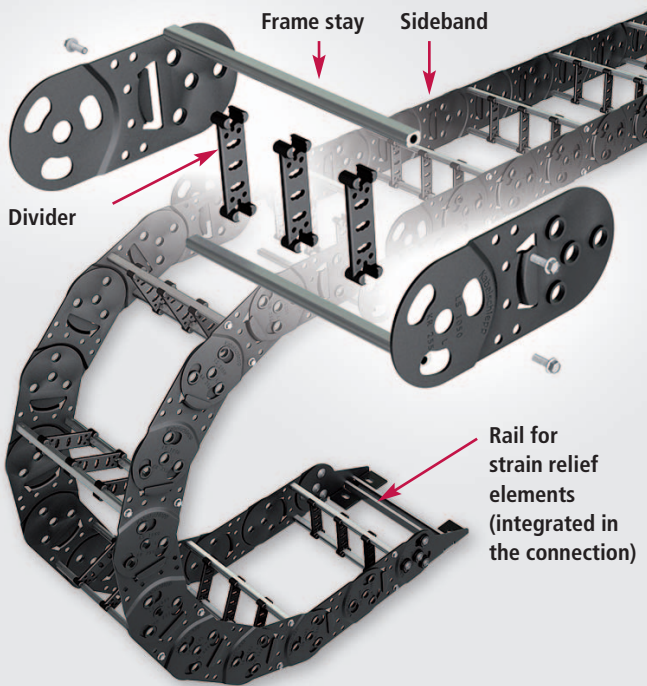

**1-plate design:**  
Weight-optimized link plates only consist of one plate. The stroke system is integrated.



**Optional central bolts**  
for applications with high loads.



**Shortening and extending the cable carrier**  
by connecting the chain plates.

### Carrier construction S/SX Series

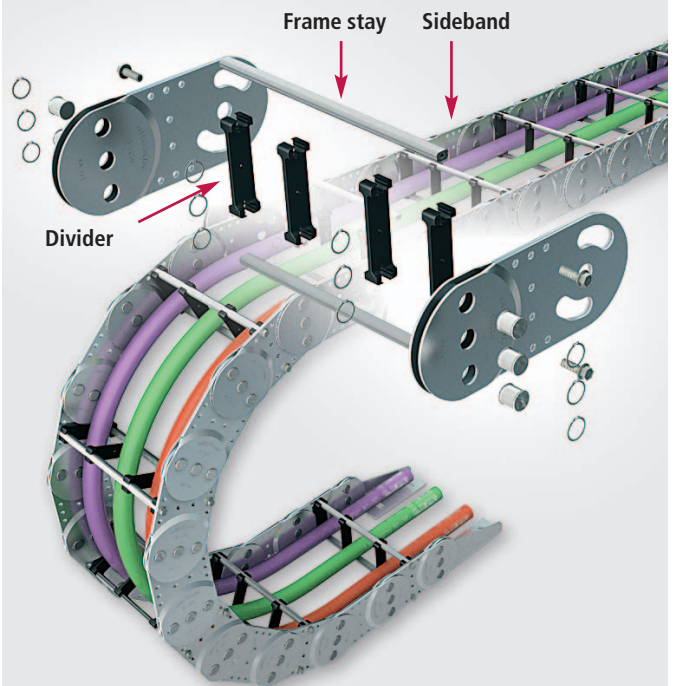

**Sandwich design:**  
The chain link plates consist of two plates welded together.



**Stroke system**  
with special bolts and locking rings (standard version)



**Glide shoes** for gliding applications.

LS/LSX steel chains can be found starting on page 58.

S/SX steel chains can be found starting on page 74.

## Internal subdivision of the carrier cross section.

Dividers made of plastic or steel and different height subdivisions make subdivision of the carrier cross section possible. In this way, the laid cables are separated and twisting the cables with each other is prevented. See also page 49.

## Cable routing for **hole stays**

### Stay variant **LG**



With hole stays, the number and position of the cables in the cross section are taken into account exactly as regards the shape. These can be routed in the neutral bending zone.

**Benefits:**

- stable construction
- longer service life of the cables due to low relative movement of the cables for the stay

## Divider systems for **frame stays**

### Divider system **TS 0**



Vertical separations with dividers (1)

### Divider system **TS 1**



Vertical separations with dividers (1)  
Partial horizontal height subdivisions across the **entire inside width** (2)

### Divider system **TS 2**



Vertical separations with dividers (1)  
Horizontal height separators made of aluminium. **Available in 1 mm width sections** (2)

### Divider system **TS 3**



Vertical separations with dividers (1)  
Horizontal height separations with partitions made of plastic or aluminium (2). These can also be **installed at a later date or modified by changing the partitions.**



Partition made of plastic

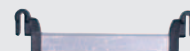

Partition made of aluminium with plastic adapters. Available in 1 mm width sections.

### Divider systems **TS 4** and **TS 5** (not illustrated)

**Divider system TS 4:**

Half-dividers and continuous height subdivision

**Divider system TS 5:**

Hole stay inserts made of plastic – split design

LS/LX Series

S/SX Series

CONDUFLEX  
MOBIFLEX

TRAXLINE  
TOTALTRAX

Accessories

Application  
Examples

# Stay variants.

## The appropriate solution for every application.

### Stay variant RS 2 – with bolted stays

- frame stay RS made of aluminium – standard design
- for lightweight to medium loads
- available for the types:  
LS/LSX 1050, S/SX 0650, 0950 and 1250

- **Standard stay arrangement:**  
on every 2nd chain link.  
Stays can be fitted on every chain link, please specify when placing your order.
- bolted stays for maximum stability

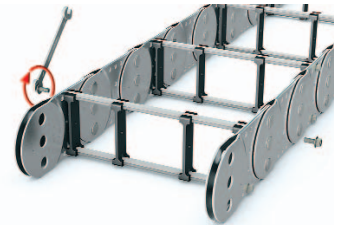

### Stay variant RS 1 – with a detachable stay

- frame stay RS made of aluminium – standard design
- for lightweight to medium loads
- available for the types:  
S/SX 0650, 0950 and 1250
- **Standard opening options:**  
**Outside:** The cable carrier can be opened quickly and easily simply by rotating the stays through 90°.  
**Inside:** Screwed stays

- Also optionally available with stays bolted on the inside and outside which can be opened by turning. Please state when ordering.
- **Standard stay arrangement:**  
on every 2nd chain link.  
Stays can be fitted on every chain link, please specify when placing your order.

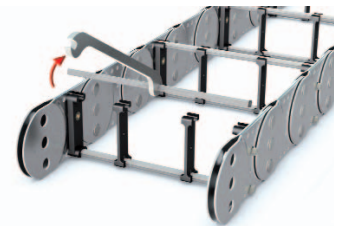

### Stay variant RV – frame stay, reinforced design

- frame stay RV made of aluminium – reinforced design
- for medium to heavy loads and for large chain width
- available for the types:  
LS/LSX 1050 and S/SX 1250

- **Standard stay arrangement:**  
on every 2nd chain link.  
Stays can be fitted on every chain link, please specify when placing your order.
- bolted stays for maximum stability

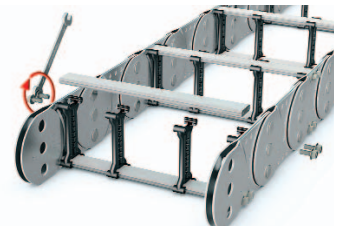

### Stay variant RM – frame stay, solid design

- frame stay RM made of aluminium – solid design
- for heavy loads – maximum chain widths possible
- available for the types:  
S/SX 0950, 1250, 1800 and 2500

- **Standard stay arrangement:**  
on every 2nd chain link.  
Stays can be fitted on every chain link, please specify when placing your order.
- bolted stays for maximum stability

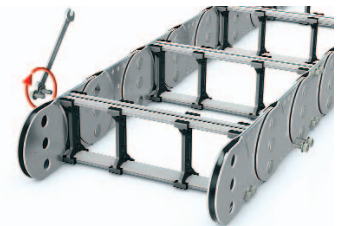

### Stay variant RMA – mounting frame stay

- for very large cable diameters such as with air hoses
- cables with diameters greater than the clearance height of the chain links can be routed
- installed on the inside or outside in the bend radius according to preference
- available for the types:  
LS/LSX 1050, S/SX 0650 and 1250

- **Standard stay arrangement:**  
on every 2nd chain link.  
Stays can be fitted on every chain link, please specify when placing your order.
- bolted stays for maximum stability

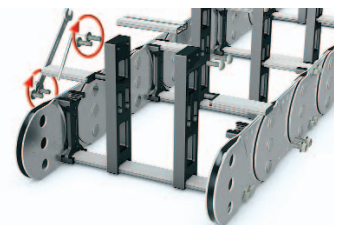

### Stay variant RMR – frame stay with plastic roller system

- gentle cable support due to rotating plastic tubes
- ideal when using media hoses with "soft" sheaths
- available for the types:  
S/SX 0950 and 1250
- stay profile made of aluminium – rollers made of plastic

- dividers in roller version
- **Standard stay arrangement:**  
on every 2nd chain link.  
Stays can be fitted on every chain link, please specify when placing your order.
- bolted stays for maximum stability

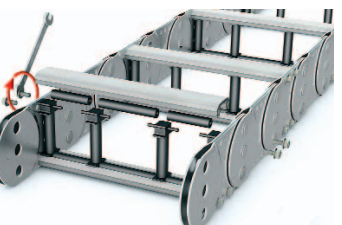



### Stay variant RR – frame stay, tube design

- ideal when using media hoses with "soft" sheaths
- gentle cable support due to rotating metal tubes
- available for the types:  
LS/LSX 1050, S/SX 0650, 0950, 1250 and 1800
- possible materials of the axles, tubes and dividers:
  - axles, galvanized steel with plastic dividers
  - axles and dividers made of galvanized steel
  - axles and dividers made of stainless steel ER 1, ER 1S
- **Standard stay arrangement:**  
on every 2nd chain link.  
Stays can be fitted on every chain link, please specify when placing your order.
- bolted stays for maximum stability

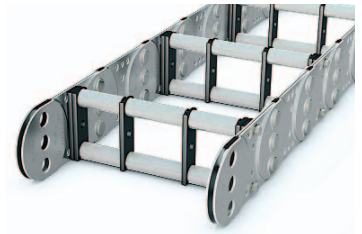

LS/LSX Series

### Stay variant LG – hole stay made of aluminium, split design

- optimum cable guidance in the neutral bending line is possible
- drilling pattern individually adapted to the application
- available for the types:  
LS/LSX 1050, S/SX 0650, 0950, 1250, 1800, 2500, 3200, 5000, 6000 and 7000
- high stability due to solid construction
- split design as standard for easy laying of the cables
- **Standard stay arrangement:**  
on every 2nd chain link.  
Stays can be fitted on every chain link, please specify when placing your order.
- bolted stays for maximum stability  
– also available not split

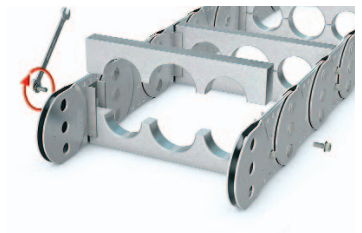

S/SX Series

#### Examples of some hole patterns:

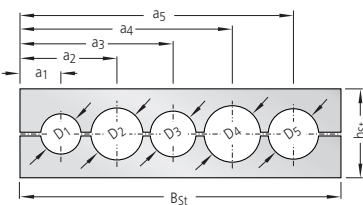

Split hole stay with individual holes

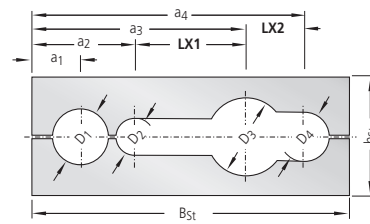

Split hole stay with offset elongated hole

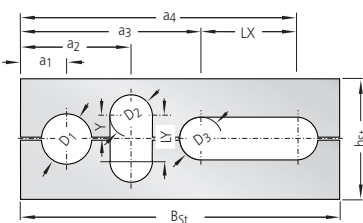

Split hole stay with horizontal and vertical elongated holes<sup>1)</sup>

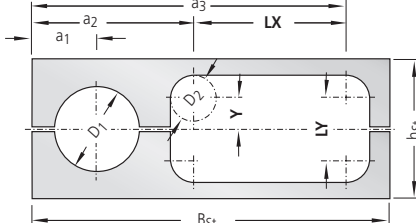

Split hole stay with rectangular elongated hole<sup>1)</sup>

<sup>1)</sup> with an off-center arrangement of the holes, the cables are subject to a relative movement when the carrier is in motion.

CONDUFLEX  
MOBIFLEX

TRAXLINE  
TOTALTRAX

### Stay variant RMD – covered cable carrier, STEEL-TUBE

- aluminium cover system for protecting the cables and hoses
- for applications where chips or severe contamination occur
- available for the types:  
S/SX 0650, 0950, 1250 and 1800
- bolted aluminium cover for maximum stability

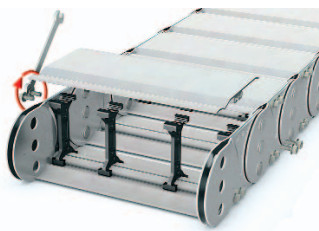

Steel band covers are also available as light-weight, economically priced alternatives to covering with the aluminium cover system<sup>2)</sup>



<sup>2)</sup> LS/LSX 1050 on request.

Accessories

### Special stays

Customized special stays are possible on request. Please contact us.

Application  
Examples

# Design of the cable carrier.

## Determining the inner dimensions

The number, type and diameter of the cables to be laid determine the inner dimensions and the inner subdivision of the cable carrier.

The space required by the cables and hoses can be calculated taking into consideration the design instructions on page 30. The installation conditions give the required clearance height and the inside width of the cable carrier.

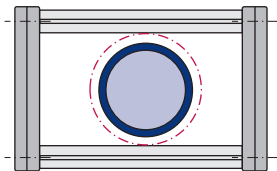

The following are guide values for the dimensions of the required free space:

- for round cables:  
10 % of the cable diameter
- for flat cables:  
10 % each of the cable width/  
cable thickness
- for hoses:  
20 % of the hose diameter



Basically, only cables which are suitable for use in cable carriers, such as e.g. TSUBAKI KABELSCHLEPP TRAXLINE cables, should be used.

## Determining the bend radius

The bend radius is determined by two factors:

1. The smallest permissible bend radius of the cables gives the smallest permissible bend radius of the cable carrier (in case of a smaller bend radius, the cables would be bent to an impermissible extent). Generally, the thickest or the stiffest cable to be carried determines the largest permissible minimum bend radius.
2. The available installation space determines the possible bend radius of the cable carrier. This must be checked with the specifications of the cables.

The following is a guide for selection of the minimum bend radius:

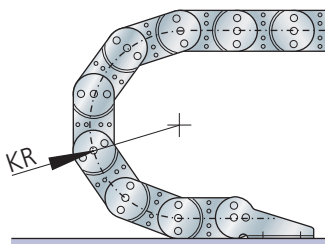

Minimum bend radius = 5...12 cable  $\varnothing$  d  
Bend radius fabrication tolerance: 0 – 5 %

**If you have any questions,  
we are happy to advise you.**

### TIP: Cable service life

A greater bend radius of the cable carrier and thus greater bend radius (than the permissible minimum bend radius) usually increases the service life of the cables. Thus, if it is possible, preferably select a somewhat larger bend radius. When using our TRAXLINE cables, a smaller bend radius can be selected in many cases.

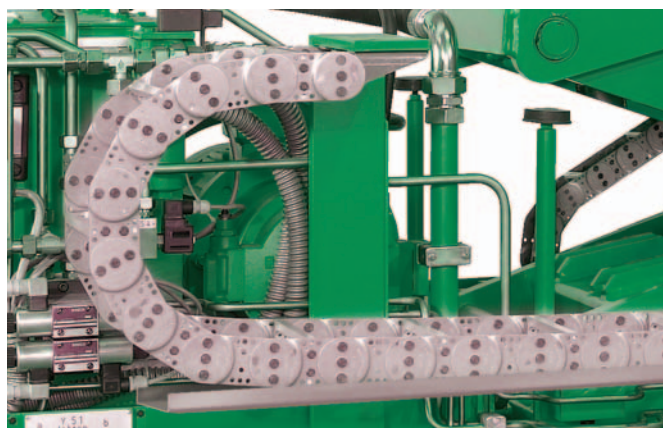

### Calculation of the chain length

Fixed point arrangement in the middle of the travel length:

**Unsupported length  $L_f$**

$$L_f = \frac{L_S}{2} + t$$

See technical data of the types for  $L_f$  approval.

**Chain length  $L_k$**

$$L_k = \frac{L_S}{2} + L_B$$

Chain length  $L_k$   
rounded off to pitch  $t$   
Bend length  $L_B = KR \cdot \pi + \text{Reserve}$

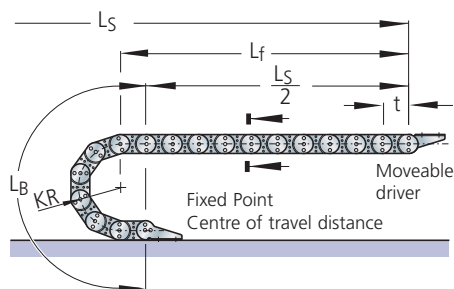

We recommend placing the fixed-point connection in the middle of the travel length. This gives the shortest connection between the fixed and movable driver point and thus the most economical chain length and cable length.

Fixed point outside the middle of the travel path:

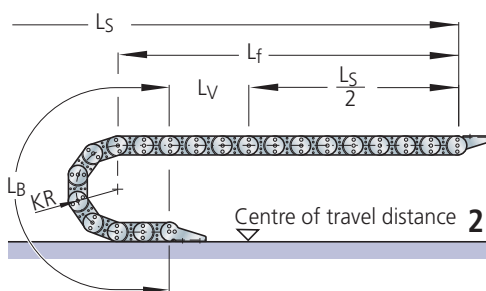
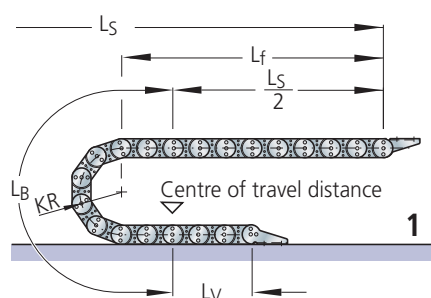

Variant 2:  
please observe greater  
unsupported length  $L_f$ .

$L_V$  = Length between connection point and middle of the travel length  
 $L_S$  = Maximum travel length of the consumer

**Chain length  $L_k$**

$$L_k = \frac{L_S}{2} + L_B + L_V$$

Chain length  $L_k$   
rounded off to pitch  $t$

### Support

The support surface must be even and the support area must be free of obstacles. If a faultless support is not available on-site, you must use a support tray.

Detailed explanations can be found starting on page 169.

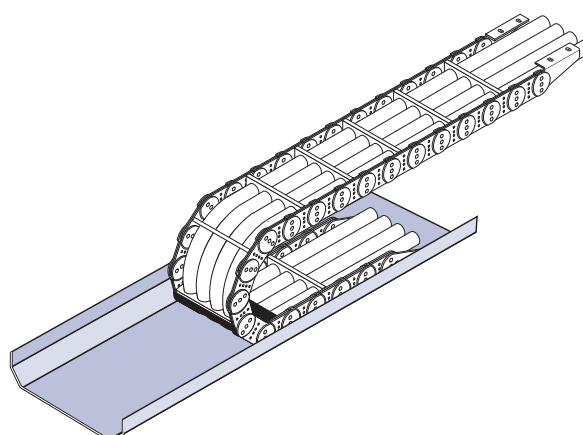

LS/LSX Series

S/SX Series

CONDUFLEX  
MOBIFLEX

TRAXLINE  
TOTALTRAX

Accessories

Application  
Examples

# Design of the cable carrier.

## Chain cover

Covered or closed cable carriers should be used for applications where chips or severe contamination occur.

Two different cover variants are available for steel cable carriers:

- Steel band covers
- Aluminium cover system (RMD stay variant)

Alternatively, our TUBE SERIES CONDUFLEX / MOBIFLEX can also be used.

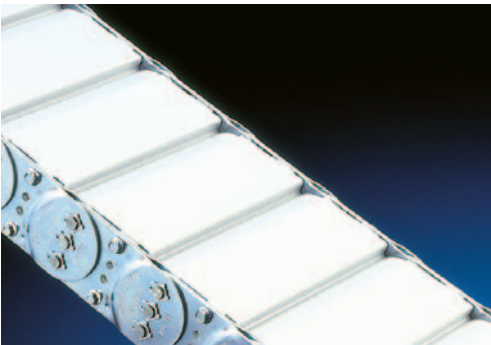

■ Detailed information about aluminium cover systems can be found with the respective types.



■ Detailed information about steel band covers can be found on page 166.

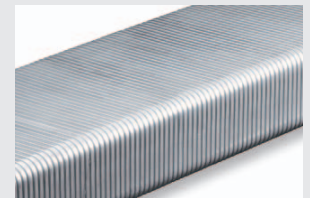
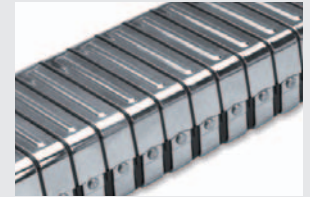

## Calculation of the connection height for steel cable carriers

Connection height  $H$

$$H = 2 KR + 1.5 h_G$$

Schematic illustration of unsupported arrangement

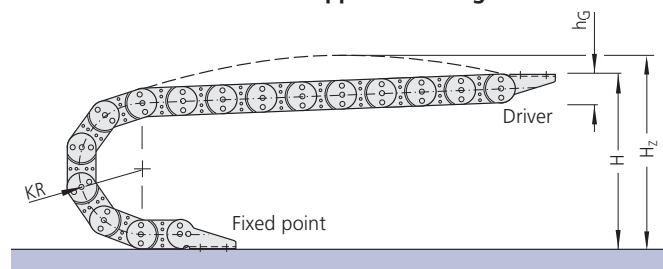

## Pretension and required installation height $H_z$

In order to achieve as large as possible unsupported length, TSUBAKI KABELSCHLEPP cable carriers are made with pre-tensioning in the standard version. The pre-tensioning

effects an elevation of the upper trough in the zone of the unsupported length. Please take account of the pre-tension when determining the required passage height  $H_z$ .

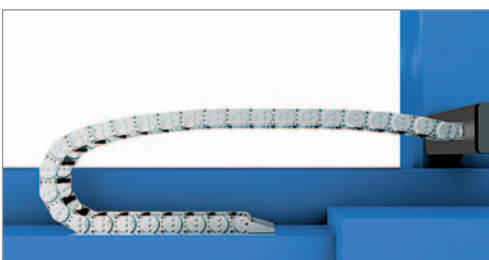

■ Cable carrier without additional load

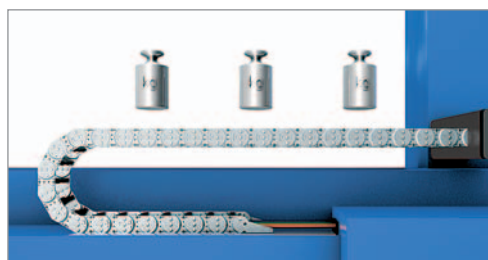

■ Cable carrier with additional load (cables and hoses)

### Chain connection – connection variants

There are no particular design requirements for connecting the cable carrier to the parts of your system. Various connection variants are possible.

- **Driver connection:**  
Attachment to moving machine or system part.
- **Fixed point connection:**  
Attachment to static machine, floor and system part.

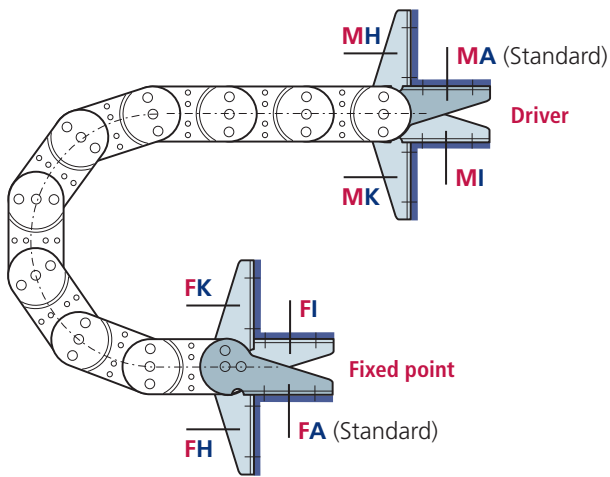

#### Point of connection

- M** – Driver
- F** – Fixed point

#### Connection type

- A** – Bolts facing outward (standard)
- I** – Bolts facing inward
- H** – Threaded joint, rotated by 90° to the outside
- K** – Threaded joint, rotated by 90° to the inside

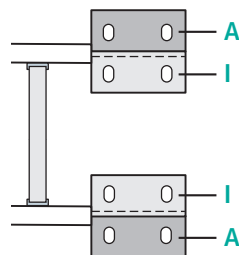

#### Connection surface

The connecting surfaces on the driver and fixed point can be mounted on the outside or inside according to preference.

- I** – connector surface inside (<math>B\_k</math>)
- A** – connector surface outside (>math>B\_k</math>)

In the standard version, the connectors are mounted with the bolting to the outside and the connecting surface to the inside (**FAI/MAI**).

LS/LX Series

S/SX Series

CONDUFLEX  
MOBIFLEX

TRAXLINE  
TOTALTRAX



Accessories

Application  
Examples

# Overview of installation variants.

Code	Symbol	Description	Page	Cable carrier design LS/LSX	Cable carrier design S/SX	Enclosed cable carriers CONDUFLEX and MOBIFLEX
EBV 01		horizontal arrangement "unsupported"	36	■	■	■
EBV 02		horizontal arrangement "unsupported – overhanging"	36	■	■	■
EBV 04		horizontal arrangement "with support"	37	▲	▲	●
EBV 05		horizontal arrangement "gliding in a guide channel"	38	–	▲	–
EBV 06		horizontal arrangement "with continuous support structure"	39	▲	▲	–
EBV 07		horizontal arrangement "rotated 90° – straight"	42	●	▲	●
EBV 08		horizontal arrangement "rotated 90° – looped"		●	▲	●

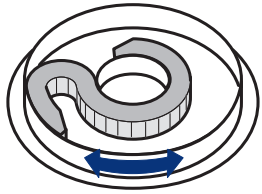
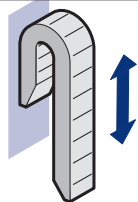
Reference: ■ Standard ▲ Customized standard product ● Special order

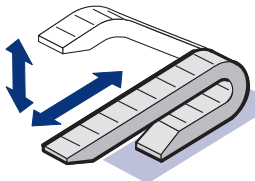
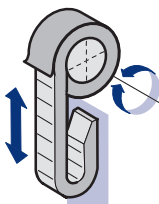
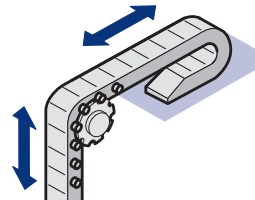
Code	Symbol	Description	Page	Cable carrier design LS/LSX	Cable carrier design S/SX	Enclosed cable carriers CONDUFLEX and MOBIFLEX	
EBV 09		horizontal arrangement "rotated 90° – circular"	43	-	■	-	LS/LSX Series
EBV 10		vertical arrangement "standing"	45	■	■	■	S/SX Series
EBV 11		vertical arrangement "hanging"	46	■	■	■	CONDUFLEX MOBIFLEX
EBV 12		horizontal/ vertical arrangement "combined"	47	■	■	■	
EBV 13		vertical arrangement "looped"	47	■	■	■	TRAXLINE TOTALTRAX
EBV 14		vertical arrangement "hanging with bearing bolts"	47	●	▲	-	Accessories

Reference: ■ Standard ▲ Customized standard product ● Special order

The installation variants shown demonstrate the many movement processes which can be triggered with a single cable carrier.

## EBV 01

### Horizontal arrangement unsupported

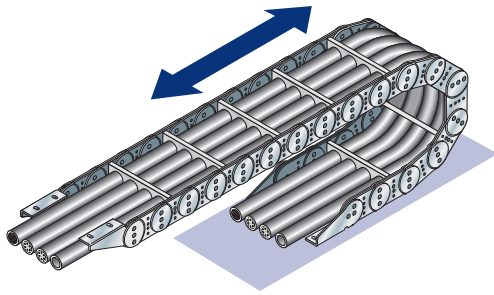

#### Note:

If you cannot find any suitable cable carrier in the unsupported range for your application, we recommend carrying out the following check:

1. Provide support for the cable carrier in the unsupported area (see installation variant EBV 04).
2. Select the "gliding in a guide channel" cable carrier system (see installation variant EBV 05).
3. Use the cable carrier system "with continuous support structure" (see installation variant EBV 06).

#### Definition:

In the case of unsupported arrangements, the driver connection of the cable carrier is fastened to the movable part of the system and moves with it in the horizontal direction.

The upper run of the cable carrier stands free, i.e. unsupported and without sag, parallel over the entire supported lower run.



## EBV 02

### Horizontal arrangement unsupported – overhanging

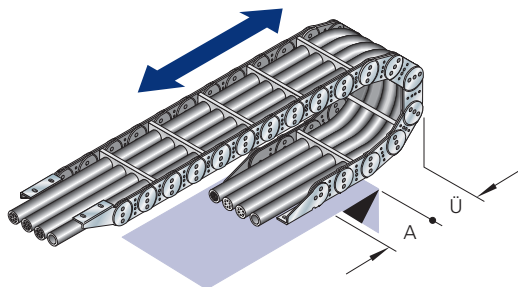

$$\ddot{U}_{\max} \leq \frac{L_f}{4}$$

#### Definition:

The lower run of the cable carrier is not supported over its total travel length. We will be happy to calculate the required measurements  $A + \ddot{U}$  for your individual application.

**Allow us to plan your application for you.**

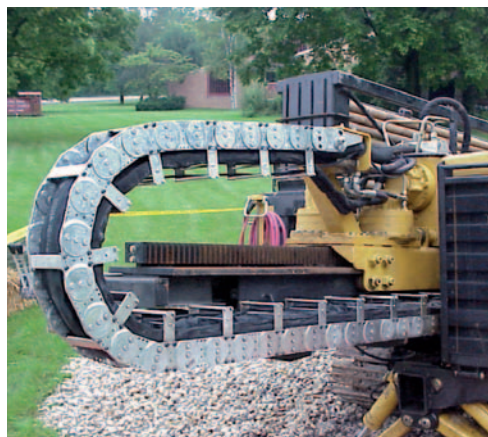



### EBV 04

## Horizontal arrangement with support using support roller(s)

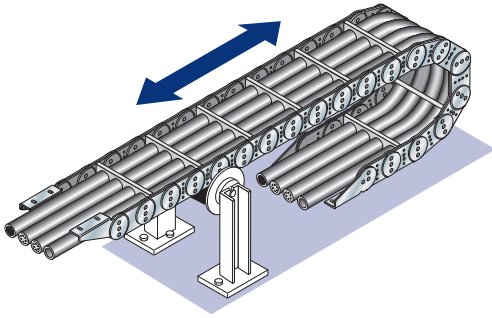

#### Definition:

If the unsupported length of the cable carrier is exceeded, the upper run can be supported.

Instead of using a TSUBAKI KABELSCHLEPP cable carrier with supports, we recommend that you use the next size up, provided that the installation conditions allow this.

**Support rollers** – see also Accessories chapter, page 170.

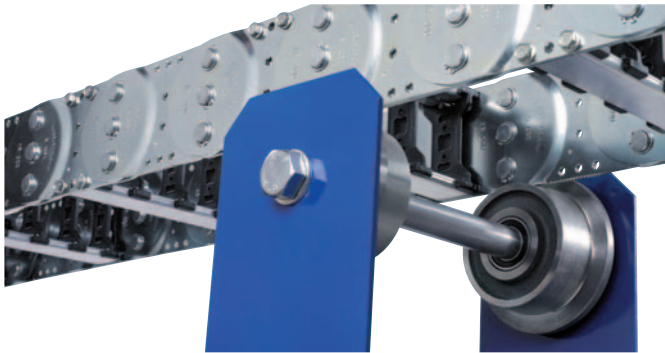

### Arrangement of support

#### Arrangement using one support roller:

when  $L_S < 3 L_f$        $a_R = \frac{L_S}{6}$

The distance of the support to the fixed point in this arrangement is approx. 1/6 of the total travel length.

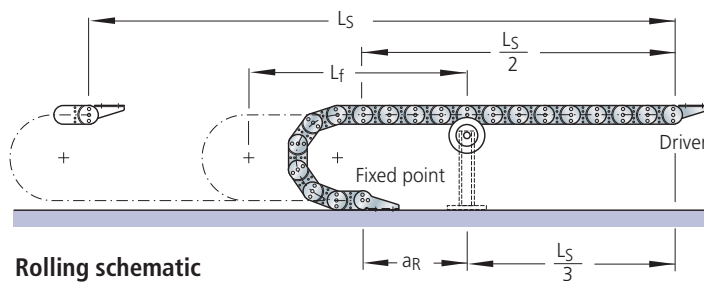

#### Special design with lateral rollers:

when  $L_S < 4 L_f$

For using the maximum possible travel length in the unsupported arrangement without travelling support construction.

Lateral rollers are mounted onto the chain links.

This kind of installation needs a flat surface, in certain cases a support tray may need to be installed.

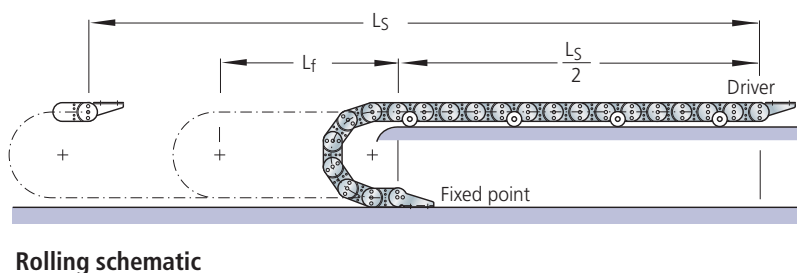

LS/LSX Series

S/SX Series

CONDUFLEX  
MOBIFLEX

TRAXLINE  
TOTALTRAX

Accessories

Application  
Examples

## EBV 05

### Horizontal arrangement gliding in guide channel

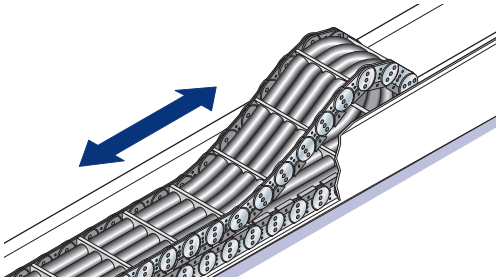

#### Definition:

The upper run of the cable carrier **glides** on the lower run or on a sliding surface of the relevant guide channel.

#### Application:

For long travel lengths, which can no longer be realised in an unsupported design.

#### Condition:

The cable carriers **must** be placed in a channel.

See page 166 for channel systems.

#### Glide elements:

Glide shoes are bolted to the side plates of the cable carrier. TSUBAKI KABELSCHLEPP provides screw-on glide shoes made of abrasion-resistant, gliding plastics. The glide friction coefficient can be reduced to a value of  $\mu < 0.2!$



■ Upper trough gliding on the lower trough

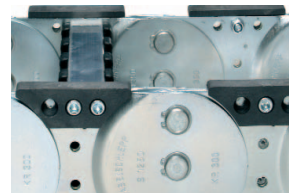

■ Standard glide shoes for S/SX 1250

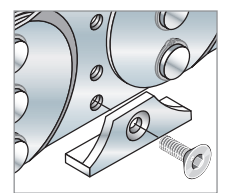

**Tip:** Replaceable glide shoes are a very cost-effective solution. When wear occurs, only the glide shoes are replaced and not the complete cable carrier.

### Arrangement of cable carrier

#### Single-sided arrangement of cable carrier

Determining the chain length:

$$L_k = \frac{L_S}{2} + L_B + KR \quad \text{rounded to pitch } t$$

$L_B$  – see technical data for selected chain type!

#### Opposing arrangement of cable carrier

The chain length is determined as for the single-sided arrangement!

It should be noted that for a moving application, both cable carriers should be designed to the same length and width.

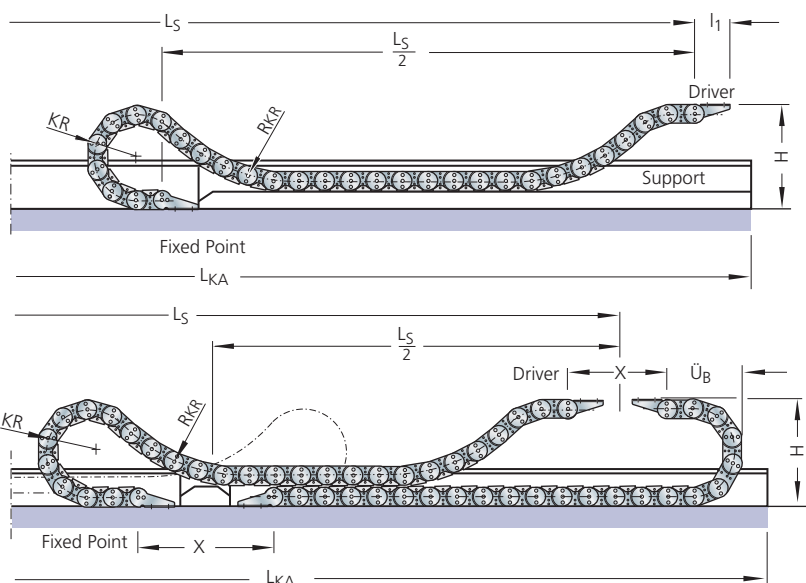

**Design information:** The support construction of the guide channel needs to have the required stability.

**Technical data – dimensional details of guide channels:** see page 166.

Because of the many design parameters which need to be considered such an installation as this should be planned and designed by our engineers!

## EBV 06

### Horizontal arrangement with continuous support structure

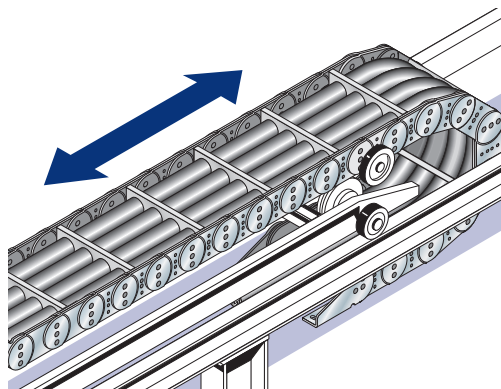

**Definition:**

If the design conditions no longer permit the installation of an unsupported cable carrier or cable carrier with underslung support rollers with regard to the travel length, the acceleration or the traverse speed, a cable carrier system can be used.

Again, the basic element is the cable carrier.

Cable carrier systems are particularly suitable for use with large travel lengths and high traversing speeds under harsh operating conditions and large loads.

Owing to the multitude of parameters which must be taken into consideration, the system should be designed by our specialists!

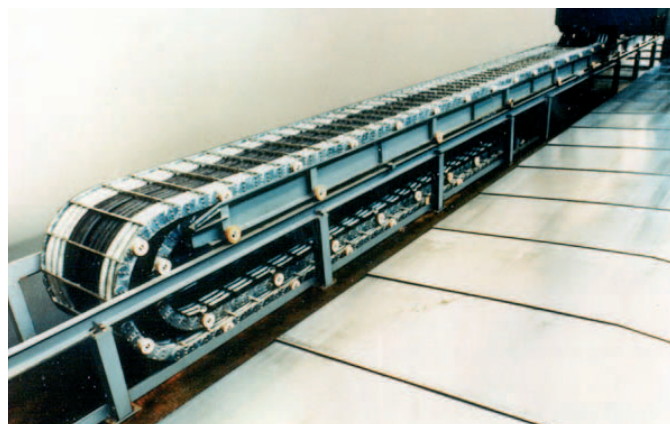

Cable carrier systems – see page 40/41.

LS/LSX Series

S/SX Series

CONDUFLEX  
MOBIFLEX

TRAXLINE  
TOTALTRAX

Accessories

Application  
Examples

# Cable Carrier System Type 225

The TSUBAKI KABELSCHLEPP cable carrier system is designed either as a one-sided system with one cable carrier or as opposing system with two cable carriers.

The cable carriers with running rollers are supported along their entire length by the support carriage which travels with the system. The supporting construction is moved in both directions using a tension cable system. The friction forces occurring on the system are minimal due to the roller support and roller guide of the cable carriers on the support carriage

and of the support carriage on the running frame. To date, TSUBAKI KABELSCHLEPP has supplied systems with the following specifications:

- maximum total travel length  $L_{s \max} = 222 \text{ m}$
- maximum travel speed  $v_{\max} = 4 \text{ m/s}$
- maximum acceleration  $a_{\max} = 8 \text{ m/s}^2$

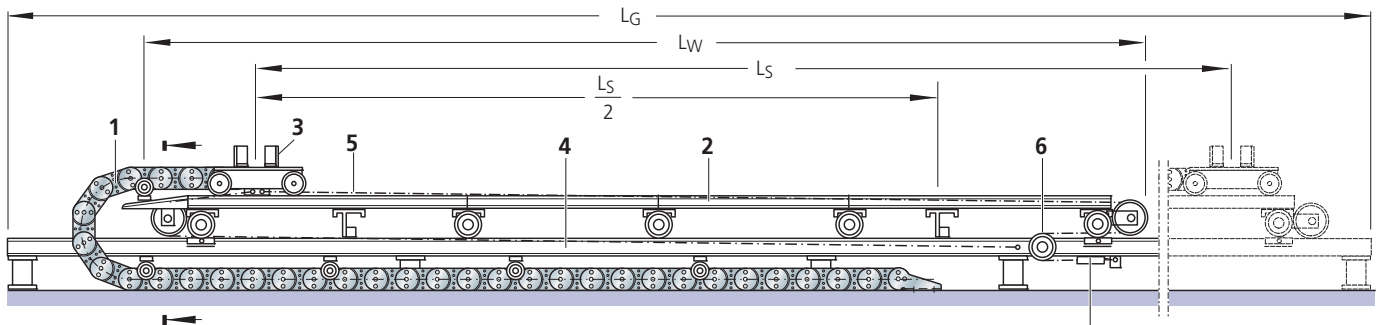

One sided arrangement (schematic illustration)

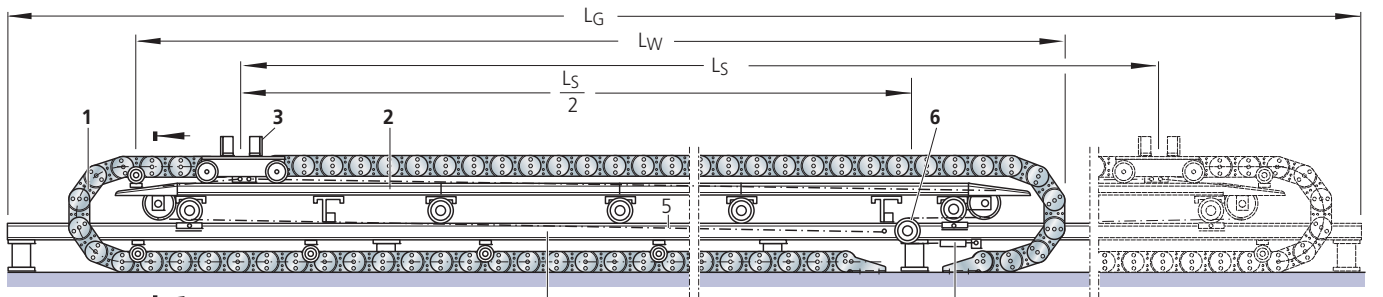

Opposing arrangement (schematic illustration)

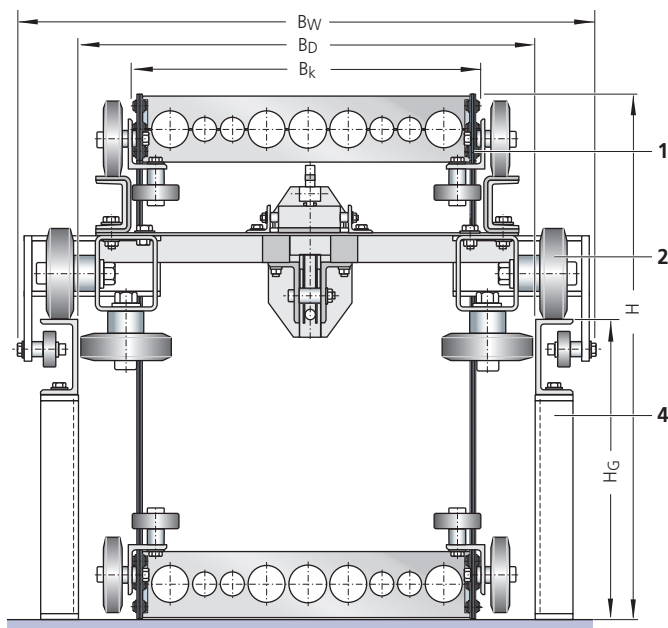

Cross-section view of cable carrier system

The TSUBAKI KABELSCHLEPP cable carrier system Type 225 consists of the following components:

- 1 Cable carrier(s)**  
with running and guide rollers attached to the side
- 2 Support carriage** with running and guide rollers providing support over the entire length
- 3 Driver carriage** with running and guide rollers
- 4 Rolling carriage**
- 5 Tension cable**
- 6 Tension cable roller**
- 7 Tensioning device**

**Abbreviations:**

- $B_D$  = Clear width in rolling carriage
- $B_G$  = Overall width of rolling carriage
- $B_k$  = Width of cable carrier(s)
- $B_w$  = Support carriage width (max. width)
- $H$  = Installation height of cable carrier(s)
- $H_G$  = Rolling carriage height
- $L_G$  = Rolling carriage length
- $L_S$  = Travel length
- $L_W$  = Support carriage length

### Cable Carrier System Type 228

For arrangement of cable carriers running in opposite directions!

The cable carriers with running rollers are supported along their entire length by the support carriage which travels with the system. The support carriage is moved by means of a tension cable system.

This cable carrier system requires less width than the Type 225 cable carrier system. The overall width is only slightly greater than the chain width  $B_k$ .

General view of the cable carrier system (schematic illustration)

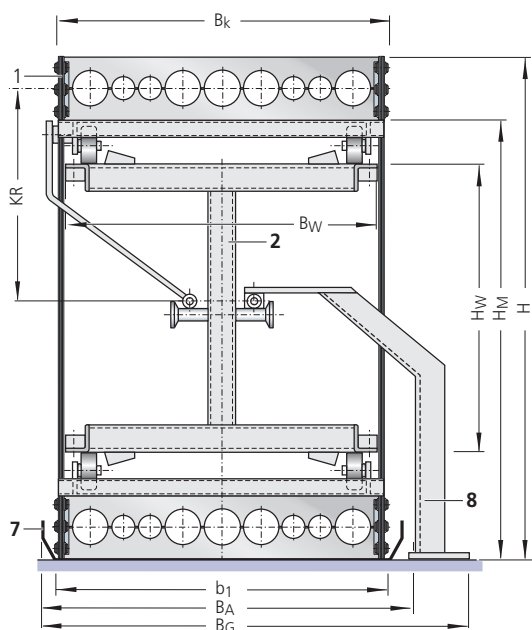
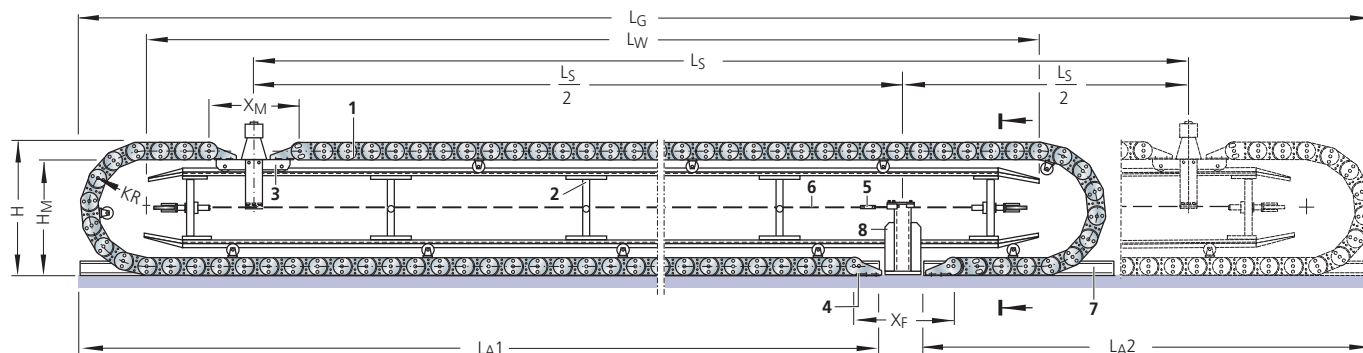

Cross-section view of cable carrier system

**Abbreviations:**

- |   |   |
|---|---|
| $B_A$ = Support tray width                  | $KR$ = Bend radius of cable carriers                |
| $b_1$ = Clear width of support tray         | $L_A$ = Support tray length                         |
| $B_G$ = Overall system width                | $L_S$ = Travel length                               |
| $B_k$ = Cable carrier width                 | $L_W$ = Support carriage length                     |
| $B_W$ = Support carriage width              | $X_F$ = Distance between connections at fixed-point |
| $H$ = Installation height of cable carriers | $X_M$ = Distance between connections at driver      |
| $H_M$ = Driver carriage height              |   |
| $H_W$ = Support carriage height             |   |

The TSUBAKI KABELSCHLEPP cable carrier system Type 228 consists of the following components:

- 1** Cable carrier(s) with running rollers
- 2** Support carriage, supporting carrier(s) along their entire length
- 3** Driver carriage with running rollers
- 4** Fixed point connection
- 5** Cable tensioning device
- 6** Tension cable with guiding rollers
- 7** Support tray
- 8** Tension cable anchor at the fixed point

LS/LX Series

S/SX Series

CONDUFLEX  
MOBIFLEX

TRAXLINE  
TOTALTRAX

Accessories

Application  
Examples

## EBV 07

### Horizontal arrangement rotated 90° – straight

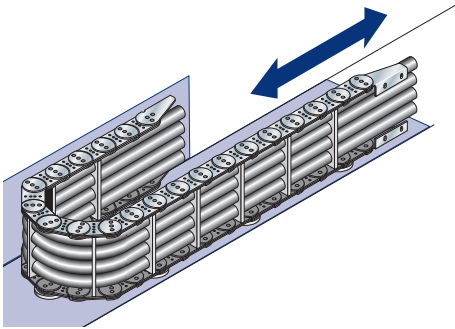

#### Definition:

This installation variant can be designed with all steel cable carriers.

The cable carrier used in the traditional horizontal arrangement is rotated through 90°. It glides on the outside of the chain band on a tray or in a channel by means of special slides or rollers.

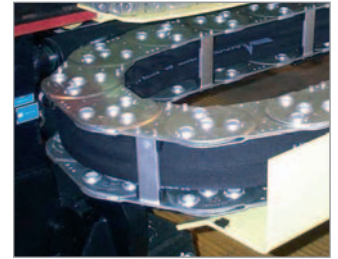

#### Application:

Generally, cable carriers turned through 90° are used if the height of the installation area is insufficient to allow a horizontal installation.

Make sure that cables/hoses are placed in the carrier with sufficient clearance from one another.

The best technical solution for this is the hole stay, which allows for the optimum placement of cables/hoses in carrier.

## Systems for extended travel lengths

### Single-sided arrangement

(with guide channel)

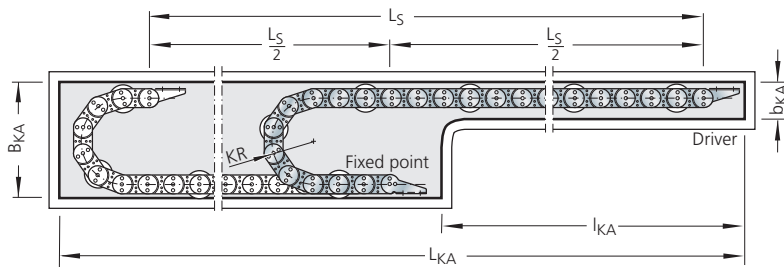

#### Abbreviations:

$b_{KA}$  = Width of restricted channel

$l_{KA}$  = Length of restricted channel

### Opposing arrangement

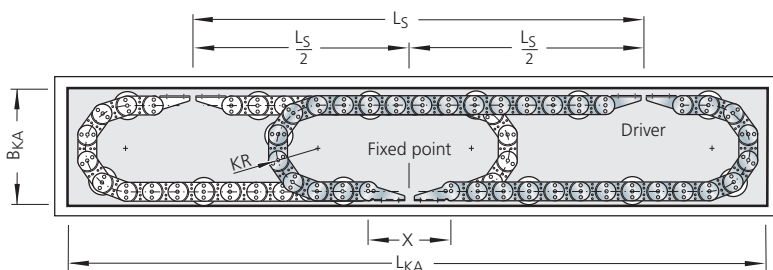

The material and quality of the channel floor must be such that a low-wear process is guaranteed with the lowest frictional forces.

The cable carriers run on plastic gliders, ball castors, steel rollers or steel rollers with rubber tyres.

Distance glides or rollers are mounted to the outside and/or inside of the chain band.

These prevent wearing of the channel walls and guarantee smooth operation of the system (see installation variant EBV 09).

## EBV 09

### Horizontal arrangement rotated 90° – circular

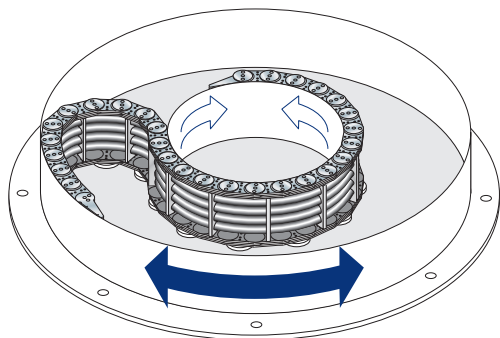

#### Application:

Cable carriers in this configuration will always have to be guided in a channel. The driver can be fitted either on the inside or the outside.

In order for the carrier system to perform a circular motion, a special chain link design is necessary.

The circular – rotated through 90° cable carriers either run on round gliders, ball castors, steel rollers or steel rollers with rubber tyres attached to the lower chain band in a sheet steel channel.

#### Definition:

In this arrangement the cable carrier is rotated through 90° for use with machine components performing circular operations.

Through the combination of bend radius KR and reverse bend radius RKR, the cable carrier deliberately moves in two precisely defined circular movements.

The carrier system is mounted to the inner and outer ring of a guide channel. The moving ring (inner or outer ring) is the driver for this installation.

#### Support and guide elements (possible combinations):

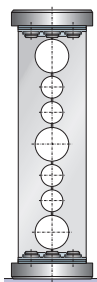

**Glidors**  
on upper and lower  
chain band\*

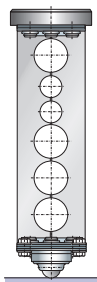

**Glidors** on upper and  
**ball castors** on lower  
chain band

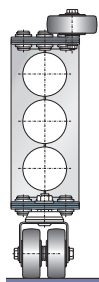

**Glidors** on upper and  
**double guiding rollers**  
on lower chain band



\*) for installations with insufficient carrier installation height  $H_E$  the glider on the upper chain band can be omitted.

The sheet steel guide channel can be delivered in two different versions:

- **Recessed channel**  
for the installation of a single-sided carrier system.
- **Continuous channel**  
for the installation of opposing carrier systems

Spacers for gliders or rollers are mounted to the inside or outside of the upper chain band in order to prevent the cable carriers dragging along the channel walls and to ensure smooth operation of the installation. With long travel lengths or particularly tall installations, a guide carriage is used to stabilize the cable carriers.

### Single-sided arrangement

with detached guide channel  
(schematic illustration)

Angles of rotation of up to **600°** are possible in a single-sided arrangement!

#### Abbreviations:

- $\alpha$  = Fixed point angle
- $\beta$  = Travel length
- $B_E$  = Width of cable carrier
- $b_{KA}$  = Channel width in the narrow section
- $B_{KA}$  = Channel width
- $H_E$  = Height of cable carrier
- $H_{KA}$  = Height of guide channel
- $KR$  = Bend radius
- $R_{KR}$  = Reverse bend radius
- $r_{KA}$  = Internal channel radius
- $R_{KA}$  = External channel radius
- F** = Fixed point
- M 1** = Driver – end position 1
- M 2** = Driver – end position 2

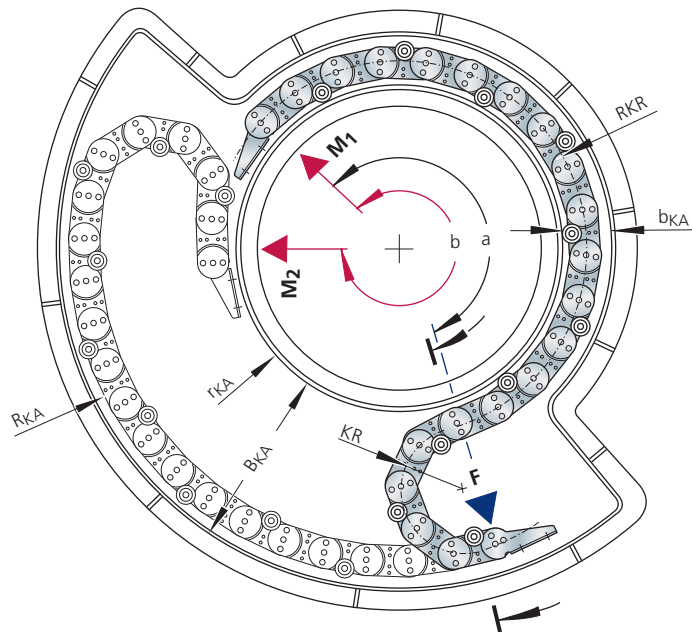

### Opposing arrangement

with guide carriage  
(schematic illustration)

Angles of rotation of up to **500°** are possible with the opposing arrangement!

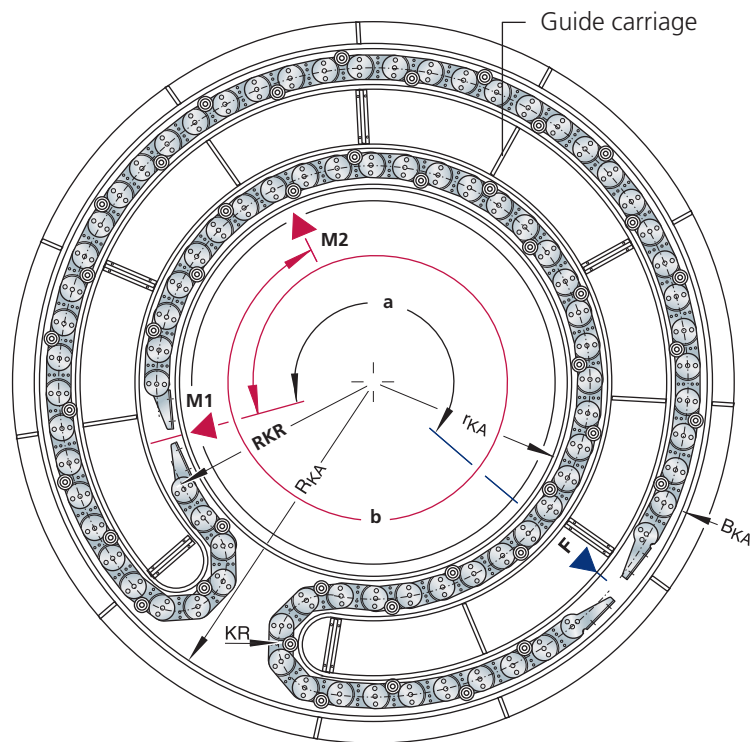

### Channel cross sectional view

Owing to the numerous design options available with this installation variant, please contact us for assistance.

We can supply the complete solution: ready to assemble, installation included if required.

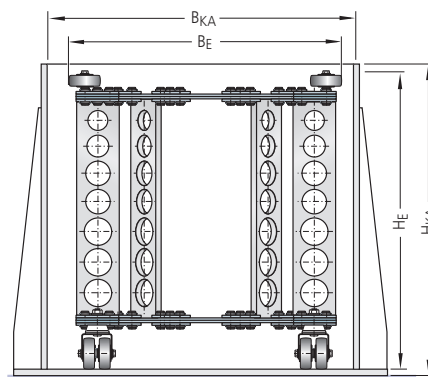



## EBV 10

### Vertical arrangement standing

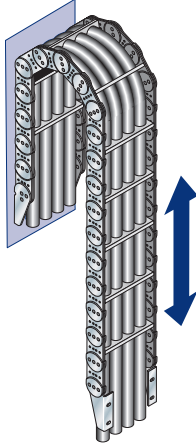

#### Definition:

Mount the cable carrier in a way to ensure parallel movement of the active and passive runs.

No or only the minimum pre-tension should be applied to the cable carrier.

Calculation of the chain length – see page 31.

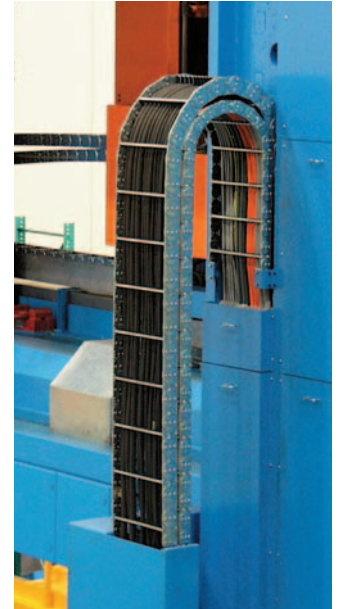

#### Connection elements

The connection elements have to be mounted to the machine (fixed-point/driver) to prevent the cable carrier from tilting to the outside, i.e. the connection has to be **rigid**.

$$H = 2 KR + h_G$$

The distance between the fixed-point and driver connection depends on the selected bend radius.

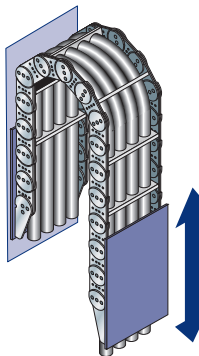
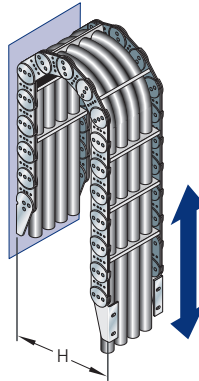

#### Support

Generally, the cable carrier has to be supported at the fixed point and on the outside of the driver.

The length of the support is determined by the additional load, degree to which the carrier is filled, travel length and the selected cable carrier.

#### Direction of movement

In some instances, the complete unit also moves **crosswise** to the carrier standing vertically.

In these cases the carrier needs to be equipped with the appropriate guides to follow this movement.

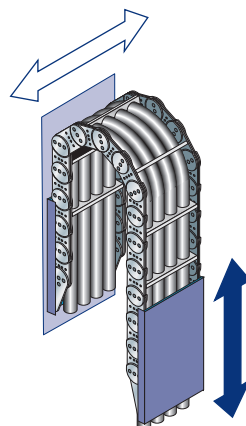

LS/LSX Series

S/SX Series

CONDUFLEX  
MOBIFLEX

TRAXLINE  
TOTALTRAX

Accessories

Application  
Examples

## EBV 11

### Vertical arrangement hanging

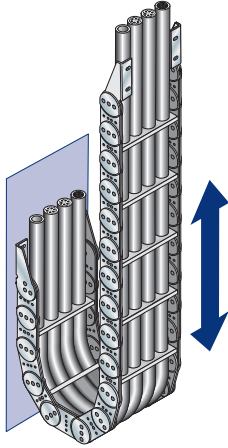

#### Definition:

We differentiate between:

#### Vertical hanging arrangement

Direction of movement of cable carrier:  
**vertical only**

In the case of a purely vertical movement, the cable carrier can be installed without special side supports.

Calculation of the chain length: see page 31.

### Vertical arrangement – hanging

Direction of movement of cable carrier:

#### vertical/horizontal combined

Even with a combined vertical/horizontal movement, the cable carrier can be installed without special side supports.

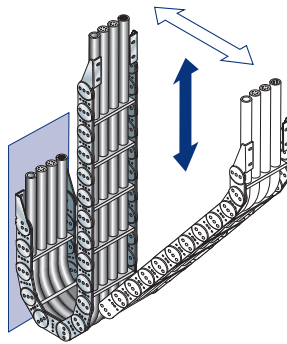

### Vertical arrangement – hanging

Direction of movement of cable carrier:

#### vertical only

If the entire unit moves crosswise and/or along to the hanging cable carrier, an additional side guide must be fitted to the longer cable carriers.

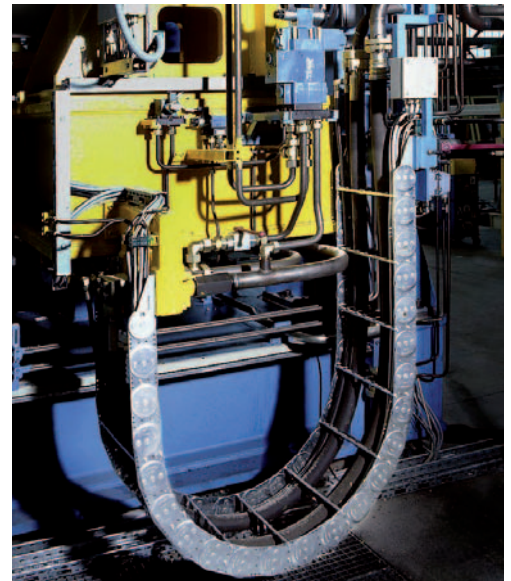
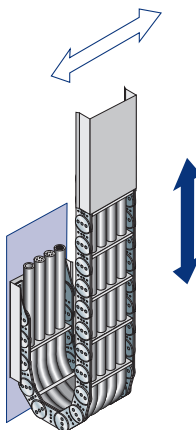

### Generally, the following applies to the vertical hanging arrangement

- The cable carrier must always be installed without any or with only minimal pretension.
- Extreme care should be taken when fixing the cables/hoses to the driver and to the fixed point.

Please comply with the **Guidelines for installing cables/hoses in TSUBAKI KABELSCHLEPP cable carrier systems.**

## EBV 12

### Horizontal/vertical arrangement combined

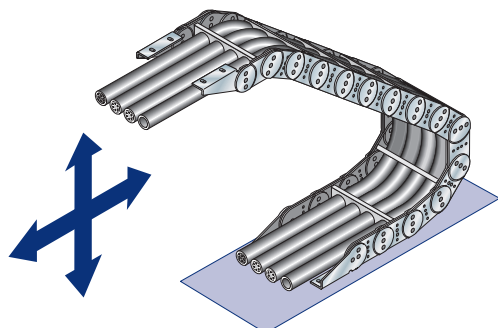

**Definition:**

KABELSCHLEPP cable carriers can also be utilized for combined horizontal/vertical motion ("Multi-axis").

This arrangement requires no special structural preconditions.

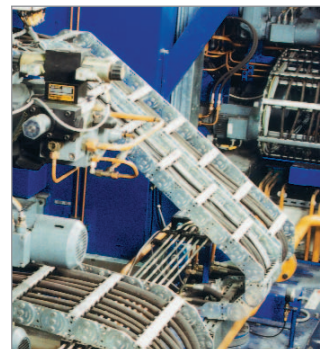

LS/LX Series

S/SX Series

## EBV 13

### Vertical arrangement looped

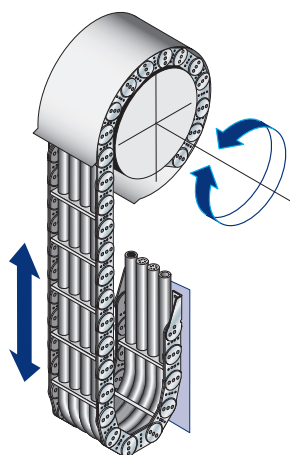

**Definition:**

For this kind of arrangement cable carriers are available in all standard versions.

Depending on spin/acceleration appropriate guide plates should be provided to ensure optimal functionality (see illustration).

CONDUFLEX  
MOBIFLEX

## EBV 14

### Vertical arrangement hanging with bearing bolts

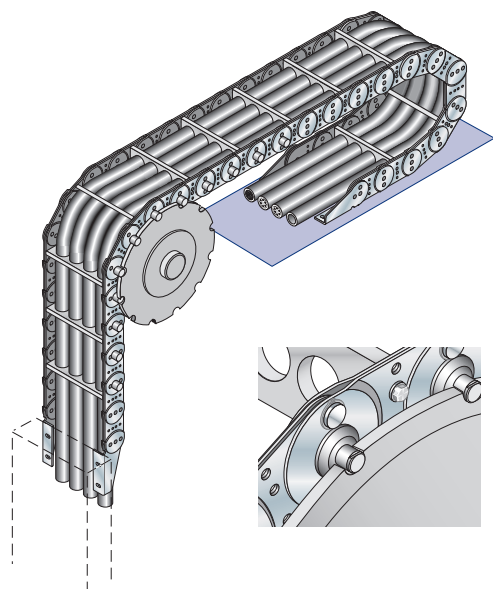

**Definition:**

This vertical arrangement of the cable carrier with additional support elements attached offers the option of using the **cable carrier as a lifting device** for machine components attached to its elements (e.g. control panels, manipulators etc.).

The cable carrier is driven by sprocket wheels.

The pitch circle radius must be equal to or larger than the selected bend radius of the cable carrier.

This installation is either motor driven or a balance weight is used.

Owing to the multitude of design options inherent to this kind of configuration, please consult our technical team about this installation variant.



TRAXLINE  
TOTALTRAX

Accessories

Application  
Examples

Below are some further options which are possible in connection with the installation variants described.

**If the cable carrier cross section is inadequate to accommodate the number of cables/hoses, the following installation options are available:**

### A1 Adjacent arrangement

Possible with all cable carriers and hoses.

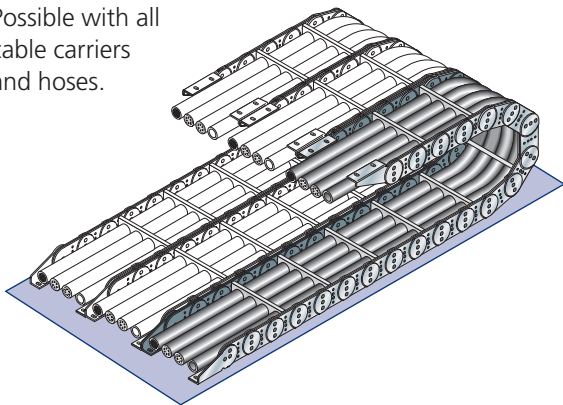

### A3 Nesting arrangement

Possible with all cable carriers and hoses.

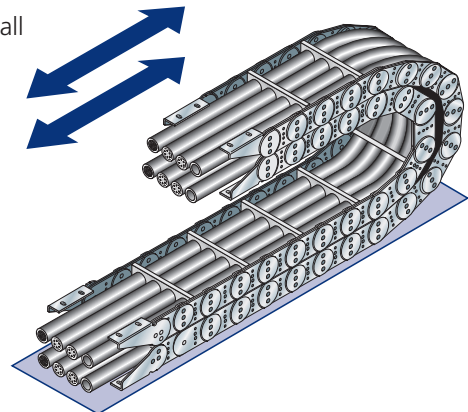

### A2 Multi-band arrangement

Possible with all cable carriers.

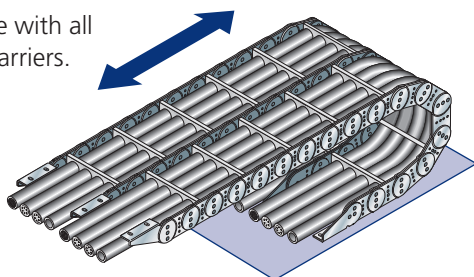

If the available space will not allow a cable carrier system to be installed because of the required width, a **nesting** or **opposing** system can be arranged.

### A4 Opposing arrangement

Possible with all cable carriers and hoses.

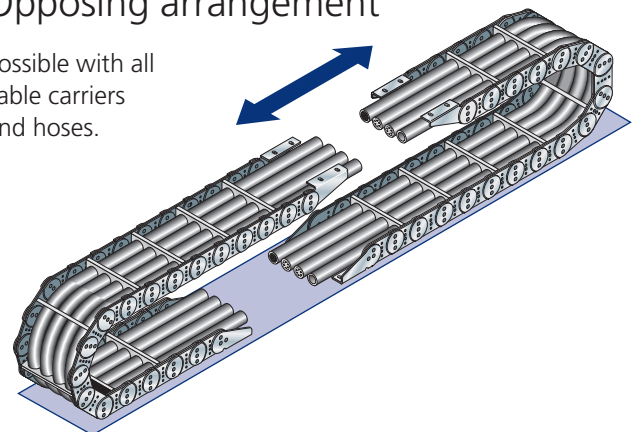

## Laying guidelines for cables and hoses.

Laying cables in cable carriers must be made extremely carefully.

Hoses must be highly flexible and may only contract or expand slightly in length when under pressure.

Information on the properties of hoses with regard to length can be found in the hose manufacturer's catalogue.

Basically, only cables which are suitable for use in cable carriers, such as e.g. KABELSCHLEPP TRAXLINE cables, should be used.



LS/LX Series

S/SX Series

CONDUFLEX MOBIFLEX

The cables and hoses must be able to move freely inside the cable carrier. They must neither be fixed in the cable carrier or bundled together.

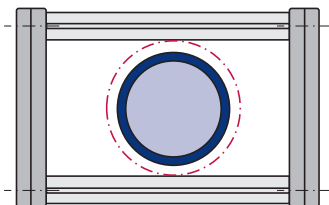

The following are guide values for the dimensions of the required free space:

- for round cables:  
10 % of the cable diameter
- for flat cables:  
10 % each of the cable width/  
cable thickness
- for hoses:  
20 % of the hose diameter

TRAXLINE TOTALTRAX

### Weight distribution for the cable laying

When laying the cables, please ensure that the cable weight is distributed symmetrically across the width of the cable carrier.

The maximum service life of the cable carrier can be achieved by uniform loading.

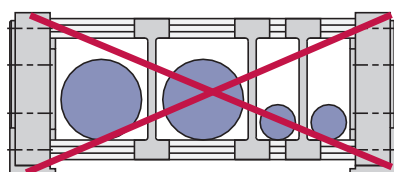

■ Unfavorable weight distribution

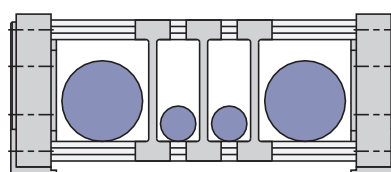

■ Favorable weight distribution

Accessories

Application Examples

**Do not raise looped cables.**

When cutting the cables for laying in the cable carrier, the coil must be arranged tangentially and not in loops for the cutting to length.

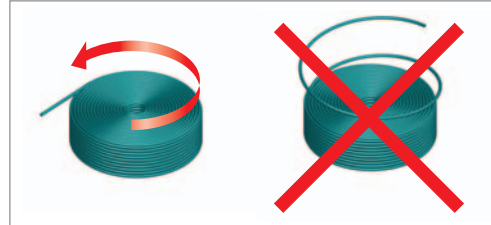

**Uncoil drum commodities without twisting.**

The drum product must be uncoiled without twisting and cut to length when cutting the cables for installing in the cable carrier.

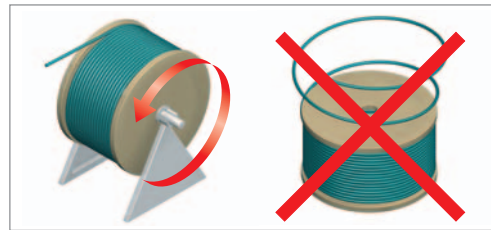

Cables lying next to each other with greatly differing diameters should be separated using dividers. Cables with greatly differing diameters lying directly next to each other must be avoided.

If laying several cables without separators is unavoidable, care should be taken that the remaining free passage height is lower than the smallest cable diameter. Only thus can the cables be prevented from getting wrapped around one another.

In the case of multi-layer laying, we recommend providing a height separation between the individual layers for electrical cables.

Custom-made hole stays or separation by means of dividers prevent cables lying next to each other from rubbing against each other. In many cases, laying every cable in a separate chamber is advantageous.

A height separation must always be provided between flat cables stacked in several layers.

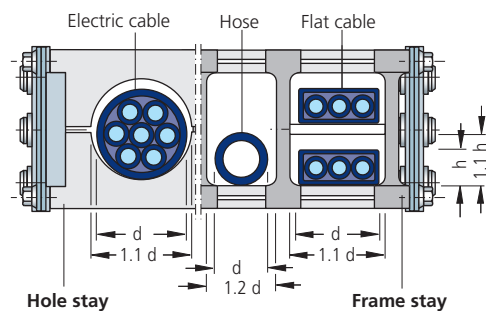
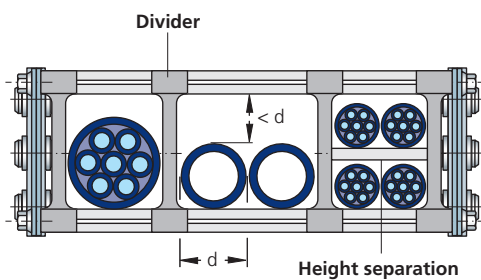

Highly flexible, thin cables with low bending strength should be installed loose side by side and arranged in a protective sheath. The cross section of the protective sheath should be chosen considerably larger than the total of the individual cable cross sections.

As a reference value for measuring the cross section, each cable should have a clearance of approx. 10 % of its diameter.

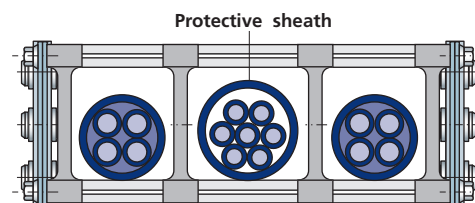

Regardless of the kind of divider used for chain stay cross-sections, the following details have to be taken into consideration:

**Pressure hoses must be able to move freely, as they may contract or expand with pressure fluctuations.**

Contraction or expansion can only be compensated for in the bend radius section of the carrier.

In order to calculate the necessary clearance, please refer to hose manufacturers' information with regard to linear expansion or contraction.

**Basically, it must be ensured that the cables can take the bend radius KR without any force being necessary.**

They must be able to move freely in the longitudinal direction and must not exert any tensile forces on the cable carrier in the chain bend.

In the case of multi-layer laying, the cables must be drawn into the cable carrier in such a way that they have a corresponding clearance between each other even in the bend of the chain.

When there is a cluster of electrical cables in covered cable carriers or in cable carrier tubes, the current carrying capacity of the cables must be designed in accordance with the applicable standards, regulations and recommendations so that the maximum permissible temperatures for the corresponding cable materials and the material of the cable carrier are not exceeded.

Please note that this is a closed system (limited convection) during the design.

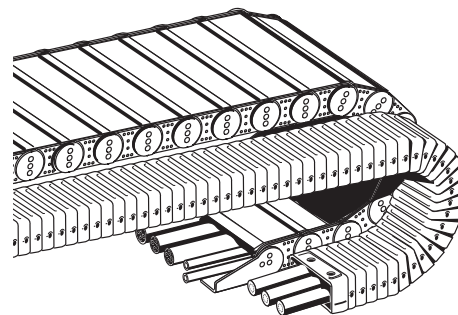
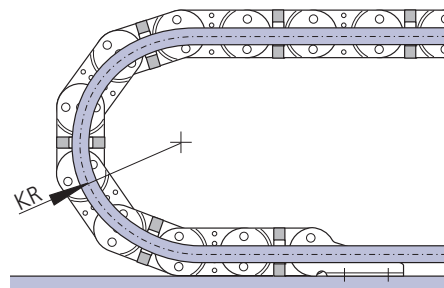
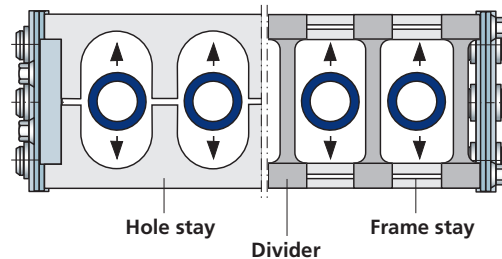

LS/LSX Series

S/SX Series

CONDUFLEX  
MOBIFLEX

TRAXLINE  
TOTALTRAX

Accessories

Application  
Examples

# Strain relief of cables and hoses.

The strain relief of the cables depends on the type of cable, the length of the cable carrier and the installation position:

Generally, it must be ensured that the stress occurs on a large area on the outer sleeve so that individual cores in electrical cables are not crushed and that displacement of the cables is not possible.

- Cables with high flexibility and low inherent stiffness must have strain relief **at the fixed point and at the driver**. Otherwise there is the risk that they will be pressed out between the chain stays.
- In the case of vertically hanging cable carriers, the cables must also have strain relief **at the fixed point and at the driver**.
- In the case of travel lengths within the unsupported area of the cable carrier, electrical cables should preferably have strain relief **at the driver and at the fixed point**.
- Pressure hoses with tailpieces which are bolted in the immediate vicinity of the driver and the fixed point do not need strain relief. If the threaded connection is further away, strain relief analogous to the electrical cables is recommended.

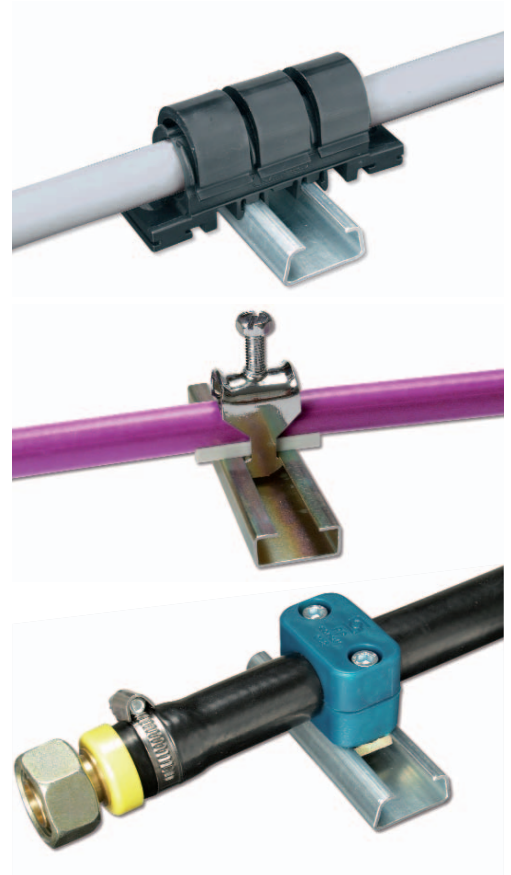

**In the case of long travel lengths in the sliding arrangement, cables should have strain relief according to the following procedure (except cables with low inherent stiffness):**

## Strain relief at the driver/end of the chain

After positioning the chain driver (moving chain end) in the **thrust end position**, the cables on the chain end to be moved have strain relief.

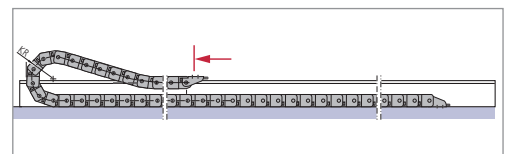

## Correct cable length in the chain

After new positioning of the chain driver (moving chain end) in the **tension end position** of the chain, the cables in the chain bend are checked for tension-free length and if necessary "pushed into the chain".

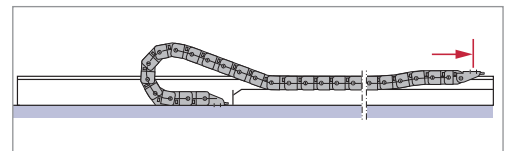

## Strain relief at the fixed point/chain end

The cables finally have strain relief at the fixed point/chain end with this tension-free "insertion length".





# Long service life of the cables.

## Frame stays made of aluminium.

Low jacket wear is an essential requirement for a long service life of the cables in the cable and hose carrier system. As well as the jacket material, the stay material as cable support is also responsible for the jacket wear.

We have examined the wear of different cables depending on the stay material in extensive series of tests.

Thereby, already existing test results have been confirmed several times. Aluminium as a support is very gentle on the sheathing of cables. This result is independent of the cable manufacturer and applies to the most common jacket materials.

As well as the good abrasion index, aluminium is particularly suitable as stay material due to its **high strength for a low intrinsic weight**. Chain widths up to 1000 mm can be achieved without the chain being particularly stressed due to additional weight.

Further information about the material characteristics of the stay material can be found on page 54.

## Save costs due to low jacket wear for cables

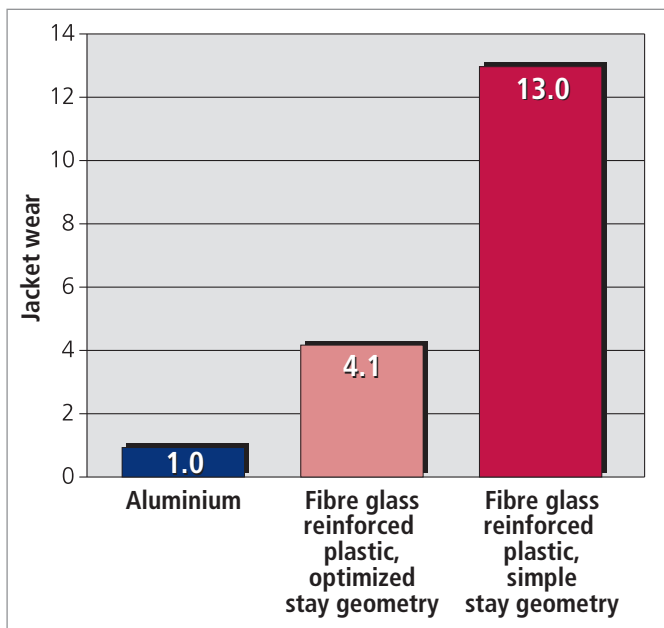

■ Jacket wear of PVC cables against stays scaled against aluminium

**TIP: Jacket wear on aluminium stays**

The jacket wear test shows up to 13 times greater jacket wear of PVC cables on plastic stays as compared with aluminium stays.



LS/LX Series

S/SX Series

CONDUFLEX  
MOBIFLEX

TRAXLINE  
TOTALTRAX

Accessories

Application  
Examples

# Material specifications.

The cable carrier material depends on its intended application. Depending on the expected level of corrosion, we can offer various materials. The zinc-plated and black coated standard versions can be used for low loads. The standard

design, in zinc-plated steel, can be used for light loads. For higher loads the carriers can be chrome-plated. In the case of extremely high specifications the high grade stainless steel option is available.

	Chain band material				
	Steel with zinc coating (standard for S series)	Steel with black special coating (standard for LS series)	Stainless steel	Stainless steel	Stainless steel
	St	Sb	ER 1	ER 1S	ER 2
Corrosion resistance	limited		good corrosion resistance in natural environment media, however without chlorine and salt concentrations (no halogens and no sea water)	Excellent corrosion resistance in the acids environment, for phosphorus and organic acids and media containing chlorides. Significantly better corrosion resistance than ER 1. Insensitive to stress corrosion cracking. Good resistance to sea water.	Excellent corrosion resistance in the acids environment, for phosphorus and organic acids and media containing chlorides. Significantly better corrosion resistance than ER 1. Insensitive to stress corrosion cracking. Good resistance to sea water.
Magnetizability	yes		no	no	present
Mechanical characteristic	high strength, good load-bearing capacity		low strength as standard material; reduced by approx. 30 % for unsupported lengths	low strength as standard material; reduced by approx. 30 % for unsupported lengths	high strength, good load-bearing capacity (as for standard material)
Applications	All application areas which do not require any particular corrosion protection, in particular general mechanical engineering and plant construction, and application areas in which no plastic cable carriers are permitted due to their load-capacity, loading, elasticity and environmental conditions.		Application areas as for the standard material, however with particular requirements for the corrosion resistance.	Application areas as for the standard material, however particularly suitable for environments with <b>salt concentrations</b> such as, e.g. port facilities. Also <b>suitable for foodstuffs</b> .	Typical purposes are: chemicals and petrochemicals industry, offshore, parts and apparatus of the chemical industry, textile industry, cellulose manufacture, dye works, and in the photographic, paint, synthetic resin and rubber industries, shipbuilding

## Material table: Steel cable carriers

Material	Series			
	LS	LSX	S	SX
St			■	
Sb	■			
ER 1		■		■
ER 1S		■		■
ER 2				■

## Material information: Standard stay systems made of aluminium alloy

The advantages of alloys lie in the combination of mechanical, physical and chemical properties of these materials.

- Material: aluminium alloy**
- light, strong, hard, smooth and resistant
  - modern design
  - optimum friction and wear characteristics

- Technical Data:**
- Density: 2.7 g/cm<sup>3</sup>
  - Modulus of Elasticity: 70 kN/mm<sup>2</sup>
  - Electrical conductivity: 28 – 34 m/W mm<sup>2</sup>
  - Thermal conductivity: 1.9 – 2.1 W/k · cm
  - Heat expansion coefficient: 23.4 cm/cm k 10<sup>6</sup>
  - Strength: 215 N/mm<sup>2</sup>
  - Elongation after fracture: 12 %

Light metal alloys show no tendency towards brittleness at low temperatures.

**Application:** Hole stays, frame stay profiles, profiles to separate the cables/hoses in the chain cross-section

Stay systems using special materials are also available for applications with extreme requirements.

### Chemical resistance of the standard plastic parts.

The table on the right shows that plastic components should not be used when exposed to acid agents.

Please contact us regarding materials not listed in the table!

**Standard material:**

KS 7422

Standard color: black

Agent	Percentage of mass	Temperature °C	Resistance
Acetone	TR		●
Formic acid	10		✗
Ammonia (aqueous)	TR	+ 70	■
Ammonia		+ 20	●
Benzine	H	+ 85	●
Benzol	H		●
Bitumen	H		●
Boric Acid (aqueous)	H		●
Butyric acid	20		●
Calcium chloride (aqueous)	GL	+ 23	●
Chlorine, chlorinated water			●
Chlorine water	H		✗
Chromic acid (aqueous)	10		✗
Diesel oil	H		●
Acetic acid aqueous, conc.	95		✗
Acetic acid (aqueous)	10		■
Ethanol	40		●
Ethyl acetate	TR		●
Paints & lacquers			●
Greases and waxes	H		●
Liquid petrol. gas (DIN 51622)			●
Fluorinated hydrocarbons			●
Formaldehyde and polymac.	TR		●
Formaldehyde (aqueous)	30		■
Hydraulic oils	H		●
Potassium hydroxide	10		●
Potassium chloride (aqueous)	10		●
Potassium nitrate (aqueous)	10		●
Methyl acetate	TR		●
Milk	H		●
Lactic acid (aqueous)	10		●
Lactic acid	90		✗
Mineral oil	H		●
Sodium carbonate (aqueous)	10		●
Oil/edible and lubricating	H		●
Oleic acid	H		●
Paraffin, paraffin oil	H		●
Polyester resins	H		●
Propane gas, propyl. hydride	TR		●
Mercury	TR		●
Hydrochloric acid (aqueous)	>20		▽
Hydrochloric acid	2		✗
Lubricants, edible fats	H		●
Vaseline	H		●
Tartaric acid (aqueous)	10		●
Tartaric acid	50		■
Xylene	TR		●
Sulfuric acid	98		▽

**Abbreviations:**

- resistant
- limited resistance
- ✗ non-resistant
- ▽ soluble
- G = saturated diluted solution
- H = commercial grade
- TR = technically pure

LS/LSX Series

S/SX Series

CONDUFLEX  
MOBIFLEX

TRAXLINE  
TOTALTRAX

Accessories

Application  
Examples

# Environmental influences.

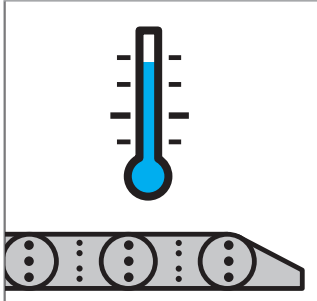

## Temperature

The cable carriers, depending on the stay type, can be used in the following temperature ranges:

Stay type	Constant temperature range
Frame stays with plastic elements	-25 °C to +100 °C
Bolted aluminium stays	-25 °C to +250 °C
Bolted tube stays (Complete steel construction, galvanized)	-25 °C to +400 °C
Tube stays (complete SX version)	-25 °C to +600 °C

Please comply with the permissible temperature range of the cables/hoses to be installed!

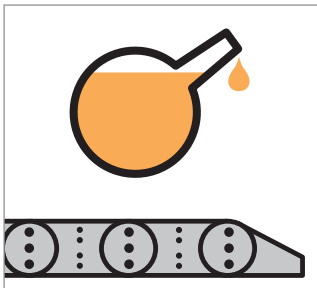

## Chemical Influences

TSUBAKI KABELSCHLEPP cable carriers with steel chain bands are resistant to many chemical influences.

Please note that the cable carriers made of galvanized steel and coated black are not resistant to acids. If the cable carriers are to be used in a harsh environment, we recommend the type with chain bands made from rust-and acid-resistant steel.

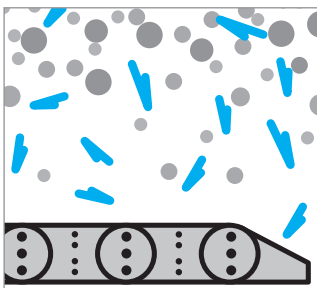

## Dust/Chips

Protection for the power supply lines against dust, contamination or other mechanical influences is provided for our cable carriers with the aluminium cover system or steel band cover.

**Stays with aluminium covers** – see stay variant RMD

**Steel band covers** – see page 172.

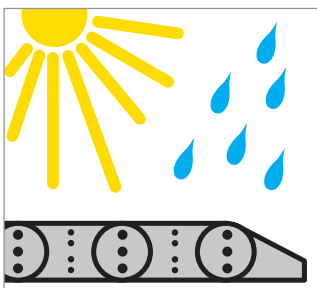

## Humidity/UV Influences

Steel cable carriers can also be used in humid areas or outside, since they are corrosion-resistant.

The plastics used for the dividers are UV resistant.

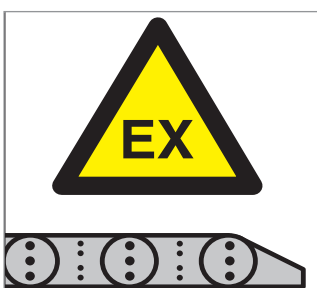

## Explosion Protection

Cable carriers with chain bands made of steel can be used in potentially explosive atmospheres. The cable carriers must be grounded via the end connectors.

**Systems of this type should be planned by our technicians. Please do get in touch with us, we would be happy to advise you.**



### SIMPLE

Stroke system is integrated in the chain link plate – no additional bolts are needed

### RELIABLE

Optional central bolts for applications with high loads\*

### FLEXIBLE

Various cable separation options

### LIGHT

Weight-optimized chain bands, specially coated or stainless steel

**STEEL**  
SPECIAL COATED

**STAINLESS STEEL**  
RUST-FREE

### INDIVIDUAL

Different stay variants of aluminium or steel available in 1 mm section widths

WIDTHSECTIONS



### SPACE SAVING

Favorable ratio of inner to outer width – no peripheral divider necessary

### VERSATILE

Dividers of plastic or steel

### VARIABLE

End connectors for different connection variants

### EASY TO ASSEMBLE

Optional C-rail for strain relief elements fixed in the connection



Lightweight steel cable carriers

# LS Series

Chain bands made of specially coated steel



# LSX Series

Chain bands made of rust and acid resistant steel

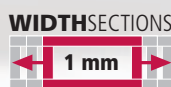

## Economically priced, light steel chains – with improved dynamic characteristic values

The chains are very light and yet very stable due to the weight-optimized link plate design. The unsupported length for the LS series is significantly higher as compared with plastic chains of the same size.

This makes the LS/LSX series approx. 40 % lighter than our steel chains of the S/SX series:

- weight-optimized, single-part chain link plates
- integrated radius and pre-tension stops – no separate bolts needed

Further details about chain design can be found on page 26.

Many stay variants with different stay cross sections make possible individual adaptation of the chain to the application. The laid cables and hoses can be optimally separated using the wide range of dividers and height separators.

A steel band cover for protection of the cables is possible on request.

## Overview of dimensions

Type	Height $h_i$	Clear width		Chain width		Pitch $t$	Page
		$B_i$ min	$B_i$ max	$B_k$ min	$B_k$ max		
LS/LSX 1050	58	84	584	100	600	105	61

Dimensions are dependent on the stay variant. Multi-band chains are possible for larger widths.

### \* Design guidelines for central bolts and stay arrangement:

- Chain length > 4 m: central bolts or stay arrangement on every chain link necessary
- Chain width  $B_{St}$  > 400 mm: central bolts or stay arrangement on every chain link necessary
- Use of support rollers: central bolts and stay arrangement on every chain link necessary





## Type LS 1050

Steel chain bands

## Type LSX 1050

Stainless steel chain bands



**2D/3D-Data**  
kabelschlepp.de/cad-gb

### Materials

**Chain bands and end connectors:**

**LS 1050:** Steel with special coating

**LSX 1050:** grade rust and acid resistant steel

**Standard stay material:** aluminium alloy\*

**Dividers:** plastic\*\*

→ see material properties, page 54



### Chain width

customer-specific

available in 1 mm width sections



### Chain pitch

105 mm

### Bend radii

various **standard bend radii**

from 105 – 430 mm; intermediate radii upon request

\* See description for the respective stay variant for details.

\*\* Stay variant RR: Dividers of steel.

### Stay variant RS

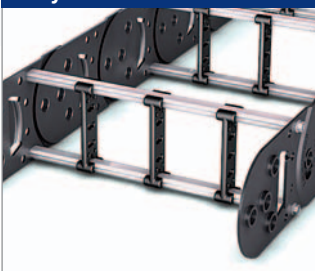

Clearance height  $h_i = 58 \text{ mm}$

➤ from page 63

### Stay variant RV



Clearance height  $h_i = 58 \text{ mm}$

➤ from page 65

### Stay variant RMA



Clearance height  $h_{i \text{ max}} = 200 \text{ mm}$

➤ from page 69

### Stay variant RR



Clearance height  $h_i = 54 \text{ mm}$

➤ from page 70

### Stay variant LG



max. hole  $\varnothing = 48 \text{ mm}$

➤ from page 71

## Type LS 1050 / LSX 1050

### Rolling schematic illustration unsupported arrangement

Chain pitch  $t$  = 105 mm  
 Height  $h_G$  = 80 mm  
 Connection height  $H$  =  $2 KR + 120$  mm  
 Connection length  $l_1$  = 117 mm  
 (see connection dimensions)

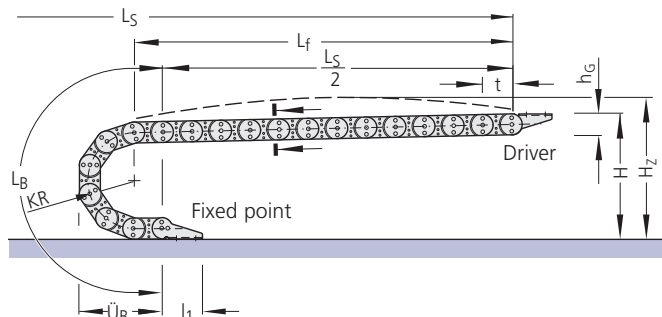

A flat and level surface is required for the cable carrier to extend and retract reliably.  
 Under certain conditions, a support tray needs to be installed (see page 167).

### Variable sizes

depending on the bend radius

Dimensions in mm

Bend radius	105	125	155	195	260	295	325	365	430
Bend length $L_B$	540	603	697	823	1027	1137	1231	1357	1561
Bend overhang $\ddot{U}_B$	250	270	300	340	405	440	470	510	575
Height $H$ (unsupported)	330	370	430	510	640	710	770	850	980

#### Chain length:

$$L_K \approx \frac{L_S}{2} + L_B$$

rounded to pitch 105 mm

#### Installation height\*:

$$H_z = H + z$$

Pre-tension  $z \approx 6$  mm/m chain length  
 \*required clear height

## Load diagramm

### Unsupported length $L_f$ and travel length $L_S$ without support

depending on the additional load (see design guidelines).

Load diagram for an intrinsic chain weight  $q_k$  of 3.8 kg/m.

If the intrinsic chain weight  $q_k$  of 3.8 kg/m is exceeded, the permissible additional load is reduced by the difference.

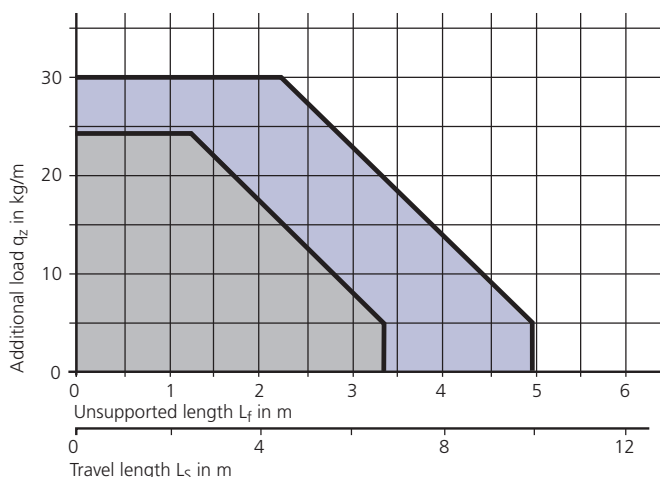

■ LS 1050 with black special coating

■ LSX 1050 material ER 1, ER 15 and LS 1050 with galvanized surface

## Type LS 1050 / LSX 1050

### Stay variant RS 2 – with bolted stays

- frame stay RS made of aluminium – standard design
- for lightweight to medium loads
- **Standard stay arrangement:\***  
on every 2nd chain link.  
Stays can be fitted on every chain link, please specify when placing your order.
- bolted stays for maximum stability

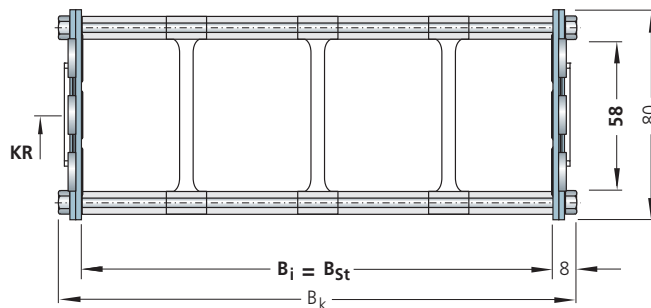
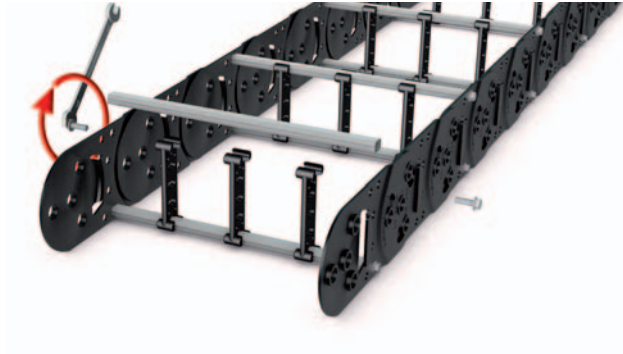

All chain cross sections according to sectional information in the schematic illustration.

#### Chain width:

$$B_k = B_i + 16 \text{ mm}$$

$$B_k \text{ min} = 100 \text{ mm}$$

$$B_k \text{ max} = 400 \text{ mm}$$

#### Stay width:

$$B_{St} = B_i$$

$$B_{St} = B_k - 16 \text{ mm}$$

### Intrinsic chain weight

#### for two band chains

depending on the chain width.

Weight of the chain bands:  
3.4 kg/m (excluding stays)

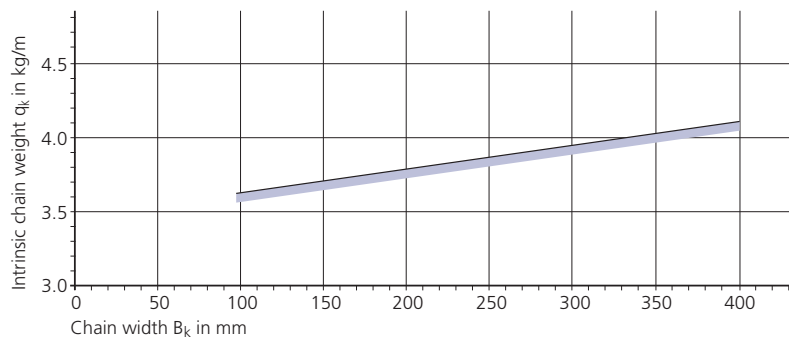

### Divider system TS 0 for stay variant RS 2

The dividers are **movable**.

$s_T$	= 4 mm
$a_T \text{ min}$	= 7 mm
$a_x \text{ min}$	= 14 mm

\* see also „Design guidelines for central bolts and stay arrangements“ on page 59.

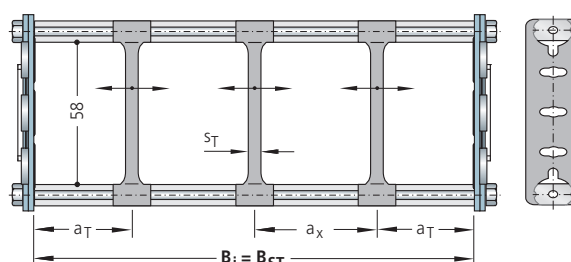

Example for ordering – divider system TS 0

TS 0	/	3
Divider system		Number of dividers $n_T$

# Type LS 1050 / LSX 1050

## Stay variant RS 2 – with bolted stays

### Divider system TS 1 for stay variant RS 2 with continuous height subdivision

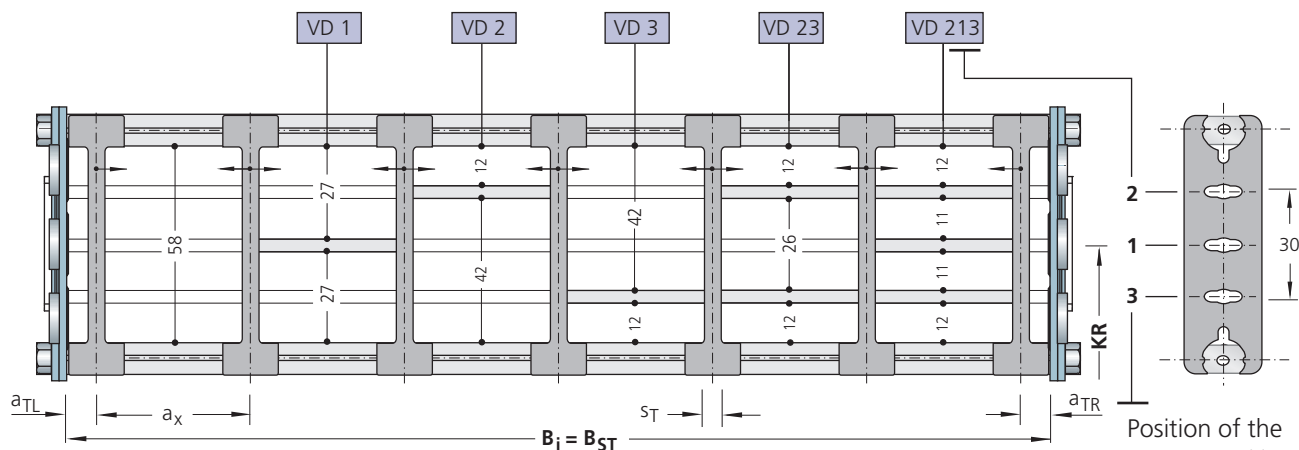

The dividers are movable. Height subdivision: Aluminium profile 11 x 4 mm

$s_T$	= 4 mm
$a_{T \min}$	= 7 mm
$a_{T \max}$	= 25 mm
$a_{x \min}$	= 14 mm
$n_{T \min}$	= 2

**Example for ordering – divider system TS 1 with continuous height subdivision**

<b>TS 1</b>	-	<b>VD 1</b>	/	<b>7</b>
Divider system		Height subdivision variant		Number of dividers $n_T$

### Divider system TS 2 for stay variant RS 2 with grid subdivision (1 mm grid)

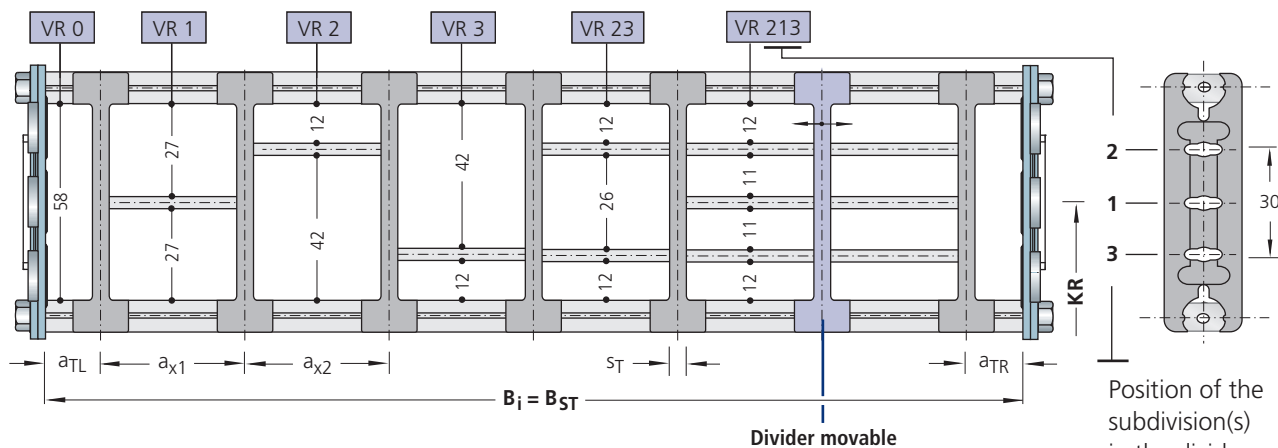

The dividers are fixed by the height subdivision, the complete divider system is movable. Optional movable dividers ( $s_T = 4 \text{ mm}$ ) are available.

Height subdivision: Aluminium profile 11 x 4 mm

$s_T$	= 4 mm
$a_{T \min}$	= 7 mm
$a_{x \min}$	= 20 mm (with height subdivision)
$a_{x \min}$	= 14 mm (for VR 0)
$n_{T \min}$	= 2

**Example for ordering – divider system TS 2 with grid subdivision**

<b>TS 2</b>	-	<b>K 1</b>	-	<b>VR 0</b>	/	<b>50</b>
Divider system		Chamber		Variant of the height subdivision in chamber		Installation interval (mm)
			<b>K 2</b>		<b>VR 23</b>	

Please state the chambers from left to right and the dimensions  $a_T/a_x$  when ordering. Possibly enclose a sketch with dimensions.

## Type LS 1050 / LSX 1050

### Stay variant RV – frame stay, reinforced design

- frame stay RV made of aluminium – reinforced design
- for medium to heavy loads and for large chain width
- **Standard stay arrangement:\***  
on every 2nd chain link.  
Stays can be fitted on every chain link, please specify when placing your order.
- bolted stays for maximum stability

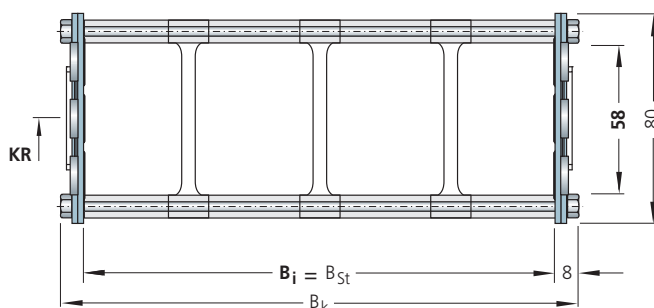
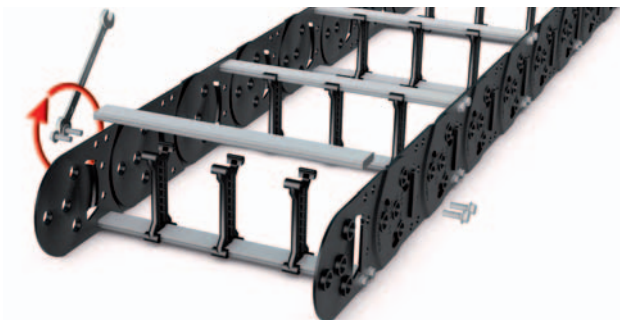

All chain cross sections according to sectional information in the schematic illustration.

#### Chain width:

$$B_k = B_i + 16 \text{ mm}$$

$$B_{k \text{ min}} = 100 \text{ mm}$$

$$B_{k \text{ max}} = 600 \text{ mm}$$

#### Stay width:

$$B_{st} = B_i$$

$$B_{st} = B_k - 16 \text{ mm}$$

### Intrinsic chain weight

#### for two band chains

depending on the chain width.

Weight of the chain bands:  
3.4 kg/m (excluding stays)

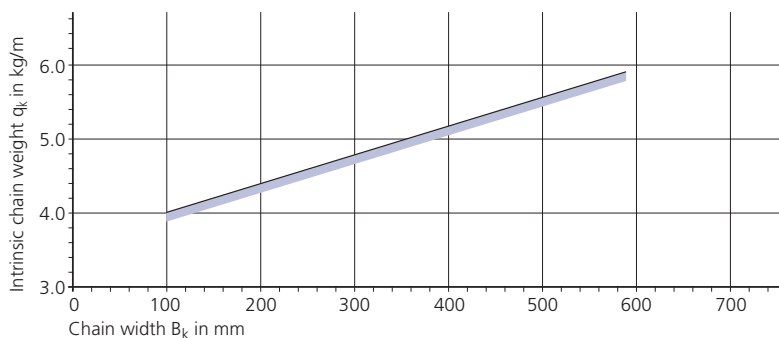

### Divider system TS 0 for stay variant RV

The dividers are **movable**.

$s_T$	= 4 mm
$a_T \text{ min}$	= 7 mm
$a_x \text{ min}$	= 14 mm

\* see also „Design guidelines for central bolts and stay arrangements“ on page 59.

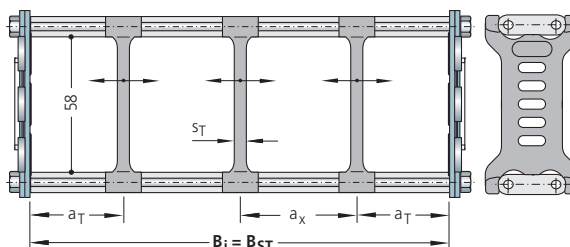

**Example for ordering – divider system TS 0**

<b>TS 0</b>	/	<b>3</b>
Divider system		Number of dividers $n_T$

# Type LS 1050 / LSX 1050

## Stay variant RV – frame stay, reinforced design

### Divider system TS 1 for stay variant RV with continuous height subdivision

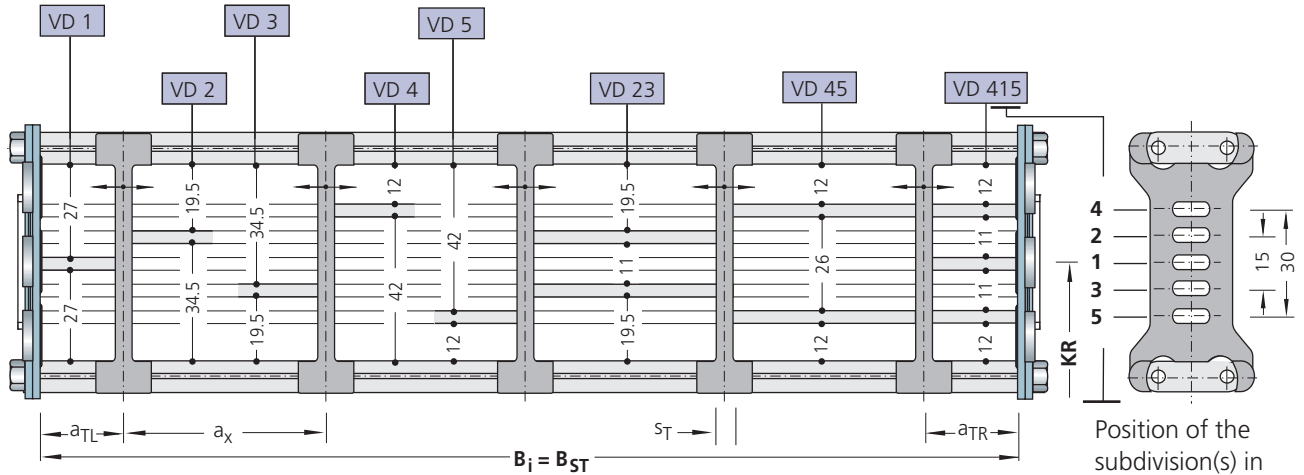

The dividers are movable. Height subdivision: Aluminium profile 11 x 4 mm

$s_T$	= 4 mm
$a_{T \min}$	= 7 mm
$a_{T \max}$	= 25 mm
$a_{x \min}$	= 14 mm
$n_T \min$	= 2

**Example for ordering – divider system TS 1 with continuous height subdivision**

<b>TS 1</b>	-	<b>VD 1</b>	/	<b>5</b>
Divider system		Height subdivision variant		Number of dividers $n_T$

### Divider system TS 2 for stay variant RV with grid subdivision (1 mm grid)

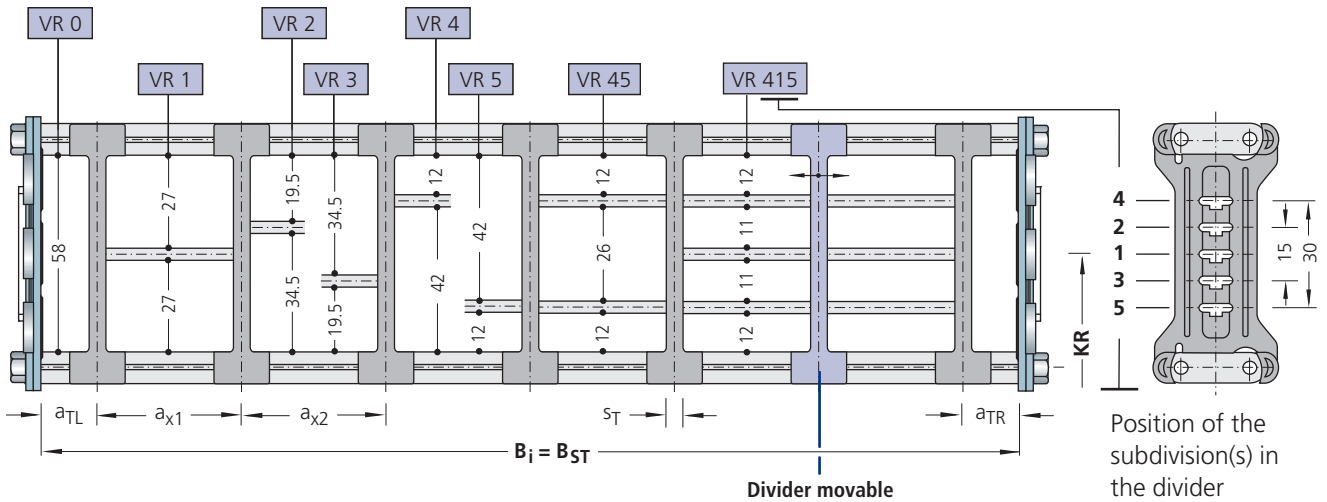

The dividers are fixed by the height subdivision, the complete divider system is movable. Optional movable dividers ( $s_T = 4 \text{ mm}$ ) are available.

Height subdivision: Aluminium profile 11 x 4 mm

$s_T$	= 6 mm
$a_{T \min}$	= 8 mm
$a_{x \min}$	= 20 mm (with height subdivision)
$a_{x \min}$	= 16 mm (for VR 0)
$n_T \min$	= 2

**Example for ordering – divider system TS 2 with grid subdivision**

<b>TS 2</b>	-	<b>K 1</b>	-	<b>VR 0</b>	/	<b>40</b>
Divider system	-	<b>K 2</b>	-	<b>VR 45</b>	/	<b>60</b>
		Chamber		Variant of the height subdivision in chamber		Installation interval (mm)

Please state the chambers from left to right and the dimensions  $a_T/a_x$  when ordering. Possibly enclose a sketch with dimensions.

## Type LS 1050 / LSX 1050

### Stay variant RV – frame stay, reinforced design

Divider system TS 3 for stay variant RV:

Section subdivision with partitions made of plastic or aluminium

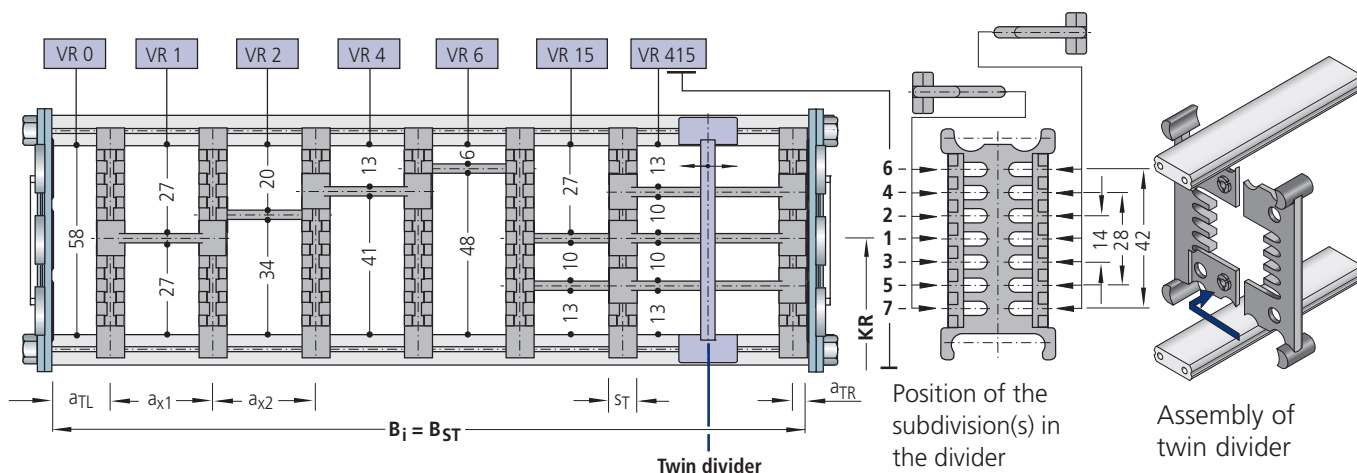

The dividers are fixed by the partitions, the complete divider system is movable.

Optional movable **twin dividers** ( $s_T = 4 \text{ mm}$ ) are available.

Twin dividers can also be assembled at a later date.

$s_T$	= 8 mm
$a_{T \text{ min}}$	= 4 mm
$a_{x \text{ min}}$	= see partitions dimensions
$n_T \text{ min}$	= 2

**Example for ordering – divider system TS 3**  
with partitions made of plastic

TS 3	-	K 1	-	VR 0	/	34
Divider system		Chamber		Variant of the height subdivision in chamber		Installation interval (mm)
		K 2		VR 1	/	38

Please state the chambers from left to right and the dimensions  $a_T/a_x$  when ordering. Possibly enclose a sketch with dimensions.

Please state additional twin dividers when ordering.

### Dimensions of the partitions for TS 3

Partitions made of plastic (Standard)

Dimensions in mm

$a_x$ (Center to center distance, dividers)									
16	18	23	28	32	33	38	43	48	58
64	68	78	80	88	96	112	128	144	160
176	192	208							

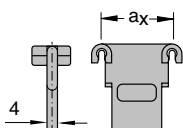

When using **partitions with  $a_x > 112 \text{ mm}$** , there must be an additional central support with a **twin divider**. Twin dividers are suitable for subsequent installation in the partition system.

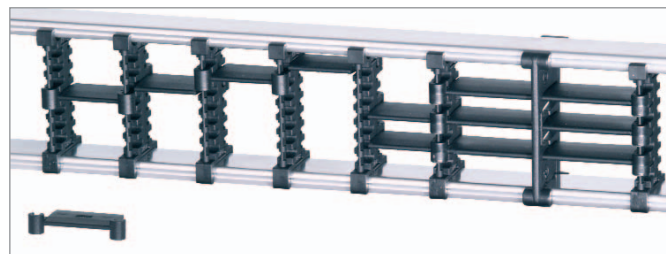

**Alternatively**, partitions made of aluminium in 1 mm section widths ( $a_x \text{ min} = 42 \text{ mm}$ ) are also available.

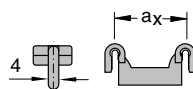

## Type LS 1050 / LSX 1050

### Stay variant RV – frame stay, reinforced design

Divider system TS 4 for stay variant RV:  
Half dividers and continuous height subdivision

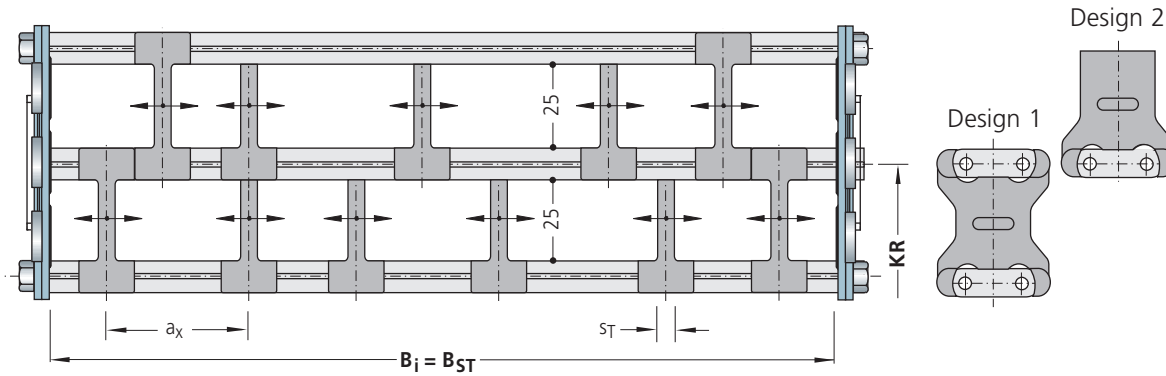

The half dividers are movable. Height subdivision: **Aluminium profile 27 x 8 mm.**  
At least 2 half dividers with wrap-around on both sides (design 1) must be installed in the top and bottom chambers in the vicinity of the chain band.

$s_T$	= 4 mm
$a_x \text{ min}$	= 15 mm

#### Ordering – divider system TS 4 with half dividers and continuous height subdivision

Please enclose a sketch with dimensions.  
Please state the  $a_T$  /  $a_x$  working clearances.



## Type LS 1050 / LSX 1050

### Stay variant RMA – mounting frame stay

- for very large cable diameters such as with air hoses
- cables with diameters greater than the clearance height of the chain links can be routed
- installed on the inside or outside in the bend radius according to preference
- **Standard stay arrangement:\***  
on every 2nd chain link.  
Stays can be fitted on every chain link, please specify when placing your order.
- bolted stays for maximum stability

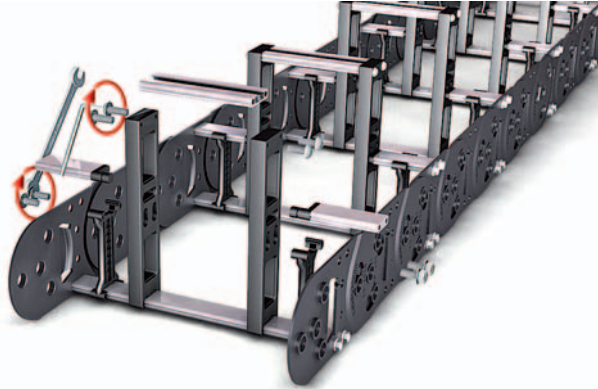

#### Chain width:

$$B_k = B_i + 16 \text{ mm}$$

$$B_{k \text{ min}} = 200 \text{ mm}$$

$$B_{k \text{ max}} = 400 \text{ mm}$$

$$B_{i1 \text{ min}} = 35 \text{ mm}$$

$$B_{i2 \text{ min}} = 84 \text{ mm}$$

$$B_{i3 \text{ min}} = 35 \text{ mm}$$

$$S_{TA} = 15 \text{ mm}$$

#### Stay width:

$$B_{St} = B_i$$

$$B_{St} = B_k - 16 \text{ mm}$$

#### Available passage heights

$$H_i = 130, 160, 200 \text{ mm}$$

#### Assembly on the inside –

observe minimum bend radius (half-stayed arrangement):

$$H_i = 130 \text{ mm: } KR_{\text{min}} = 195 \text{ mm}$$

$$H_i = 160 \text{ mm: } KR_{\text{min}} = 260 \text{ mm}$$

$$H_i = 200 \text{ mm: } KR_{\text{min}} = 260 \text{ mm}$$

Minimum bend radius full-stayed – please ask us about it.

The cable carrier must be supported on the chain band and not on the stays.

### Intrinsic chain weight

#### for two band chains

depending on the chain width.

Weight of the chain bands:  
3.4 kg/m (excluding stays)

\* see also „Design guidelines for central bolts and stay arrangements“ on page 59.

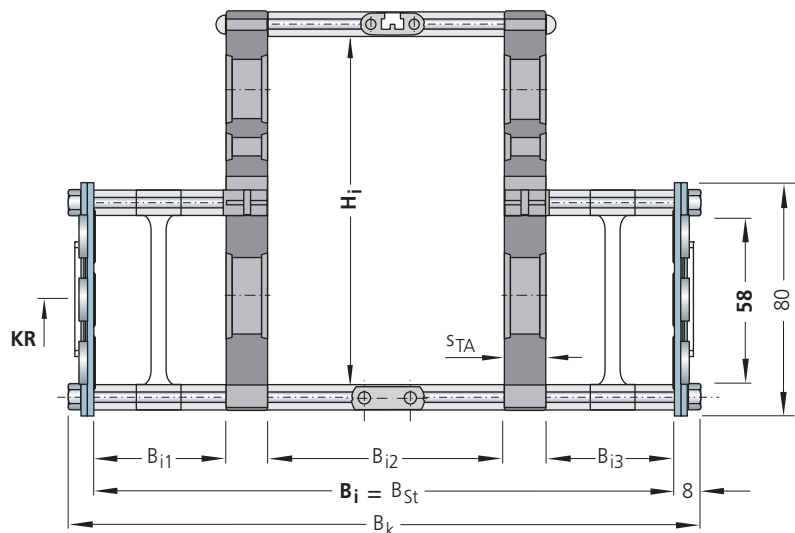

All chain cross sections according to sectional information in the schematic illustration.

On account of the design parameters to be observed, we ask you to contact our technical consultants.

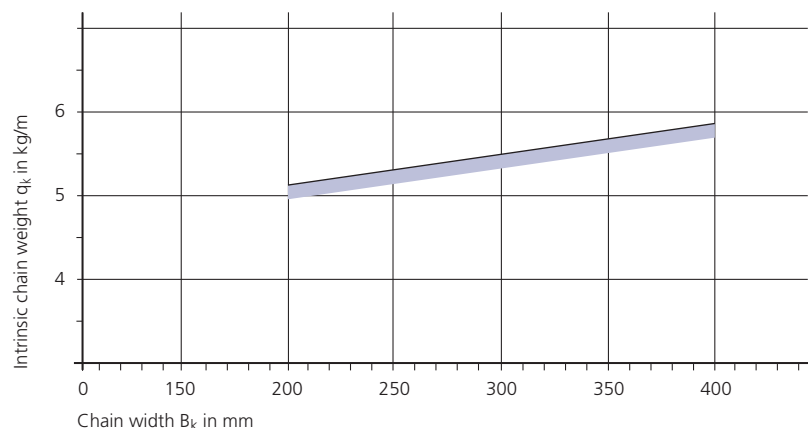

# Type LS 1050 / LSX 1050

## Stay variant RR – frame stay, tube design

- gentle cable support due to rotating metal tubes
- ideal when using media hoses with "soft" sheaths
- possible materials of the axles, tubes and dividers:
  - axles, tubes and dividers made of zinc plated (**standard**)
  - axles, tubes and dividers made of stainless steel ER 1
- **Standard stay arrangement:\***  
on every 2nd chain link.  
Stays can be fitted on every chain link, please specify when placing your order.
- bolted stays for maximum stability

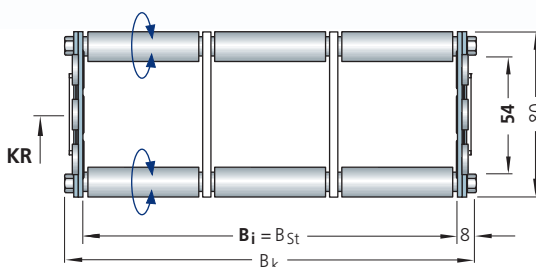

All chain cross sections according to sectional information in the schematic illustration.

### Chain width:

$$B_k = B_i + 16 \text{ mm}$$

$$B_k \text{ min} = 100 \text{ mm}$$

$$B_k \text{ max} = 500 \text{ mm}$$

### Stay width:

$$B_{St} = B_i$$

$$B_{St} = B_k - 16 \text{ mm}$$

## Intrinsic chain weight

for two band chains  
depending on the chain width.

Weight of the chain bands:  
3.4 kg/m (excluding stays)

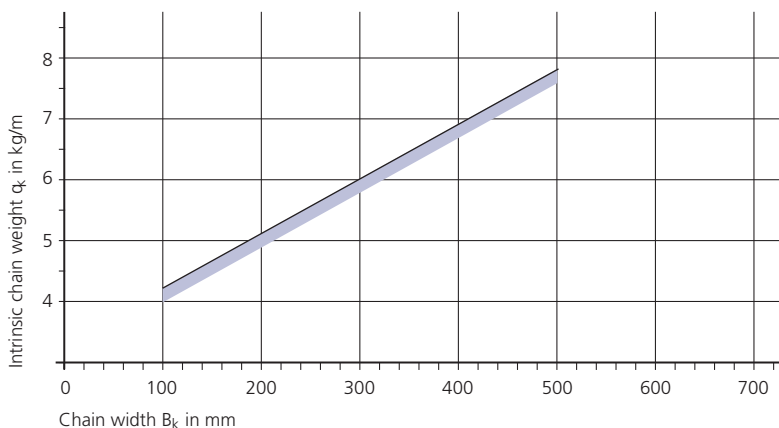

## Divider systems TS 0 and TS 1 for stay variant RR

The dividers are **fixed**.

$s_T$	= 4 mm
$a_T \text{ min}$	= 20 mm
$a_T \text{ max}$	= 25 mm
$a_x \text{ min}$	= 20 mm
$n_T \text{ min}$	= 2 (for TS 1)

\* see also „Design guidelines for central bolts and stay arrangements“ on page 59.

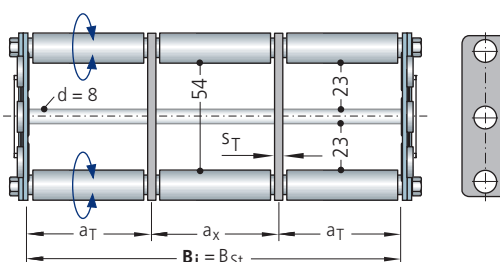

### Example for ordering – divider system

<b>TS 0</b>	/	<b>2</b>
Divider system		Number of dividers $n_T$

Please state the  $a_T/a_x$  working clearances when ordering. Possibly enclose a sketch with dimensions.

## Type LS 1050 / LSX 1050

### Stay variant LG – hole stay made of aluminium, split design

- optimum cable guidance in the neutral bending line is possible
- drilling pattern individually adapted to the application
- high stability due to solid construction
- split design as standard for easy laying of the cables
- **Standard stay arrangement:\***  
on every 2nd chain link.  
Stays can be fitted on every chain link, please specify when placing your order.
- bolted stays for maximum stability  
– also available not split

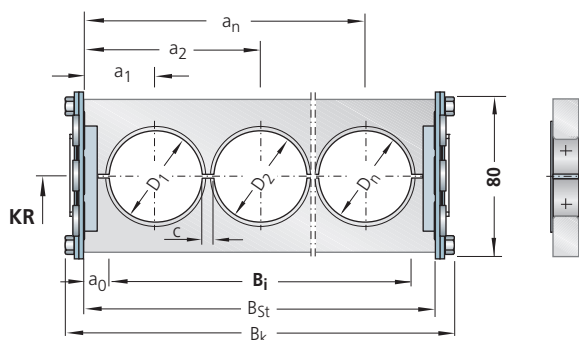
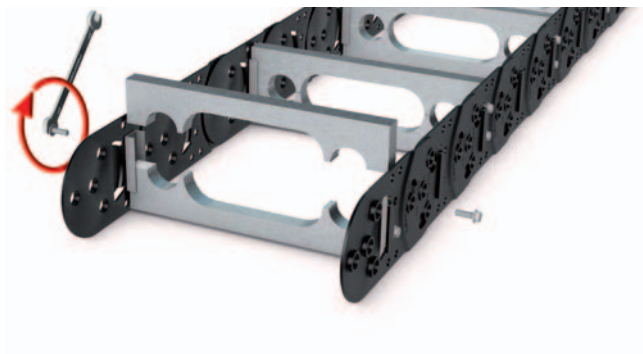

All chain cross sections according to sectional information in the schematic illustration.

#### Chain width:

$$B_k = \sum D + \sum c + 46 \text{ mm}$$

$$B_k \text{ min} = 100 \text{ mm}$$

$$B_k \text{ max} = 600 \text{ mm}$$

#### Stay width:

$$B_{St} = \sum D + \sum c + 28 \text{ mm}$$

$$B_i = B_{St} - 2 a_0$$

$$B_{St} = B_k - 18 \text{ mm}$$

$$D_{\text{max}} = 48 \text{ mm}$$

$$c_{\text{min}} = 4 \text{ mm}$$

$$a_{0 \text{ min}} = 14 \text{ mm}$$

### Intrinsic chain weight

#### for two band chains

depending on the chain width.

Hole area of the hole stay is approx. 50 %

Weight of the chain bands:  
3.4 kg/m (excluding stays)

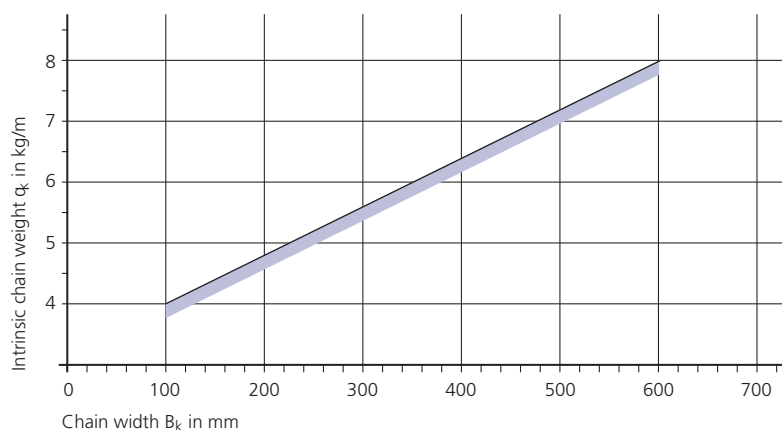

\* see also „Design guidelines for central bolts and stay arrangements“ on page 55.

# Type LS 1050 / LSX 1050

## Fixed point connection

### Connection variant FA

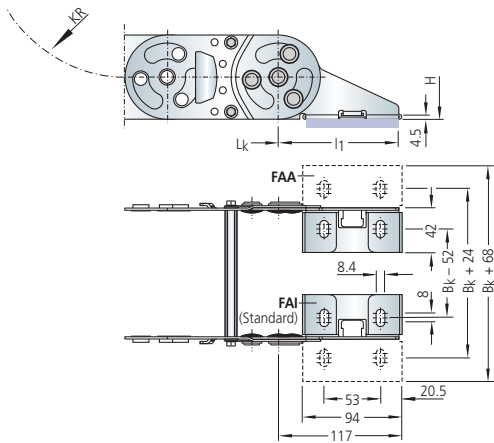

## Driver connection

### Connection variant MA

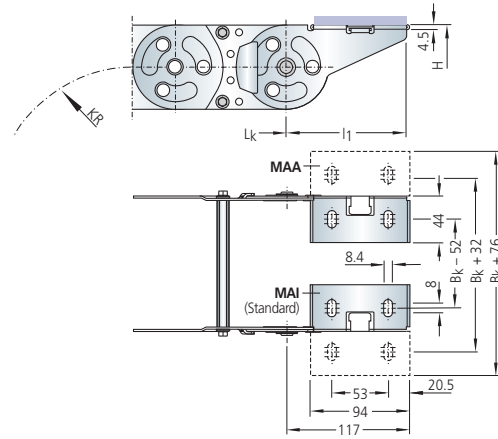

### Connection variant MI

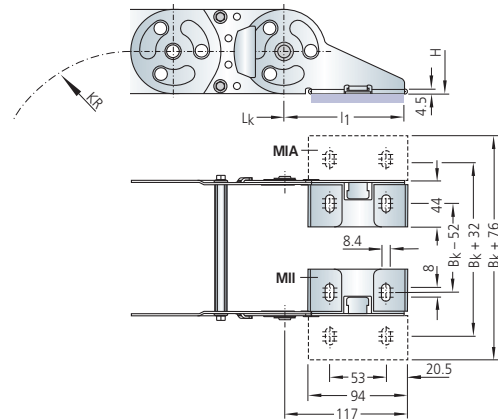

Different connection variants for fixed point and driver are possible according to the drawing information. Different end connectors are needed for different connection variants.

Please state the desired connection variant according to the ordering key (see page 73).

## Strain relief devices

The C-Rails are fixed together with the end connectors and thus do not have to be bolted separately.

### Length of the C-Rail $L_p$ :

Fixed point:  $L_p = B_i$

Driver:  $L_p = B_i + 4 \text{ mm}$

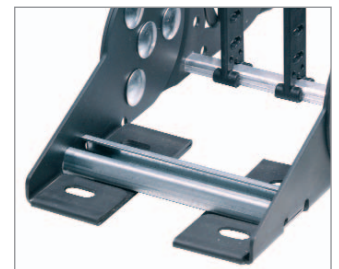

■ C-Rail fixed in the end connector.

### Dimensions C-Rail

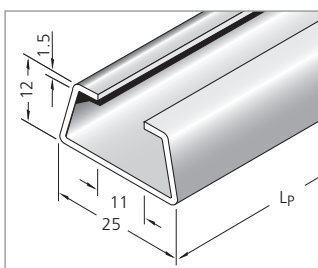

**Integratable C-Rail**  
suitable for all commercially available brackets (slot width 11 – 12 mm).

**Material**  
Steel

**Item-No.**  
3934



■ Inserting the C-Rail in the end connector.

## Type LS 1050 / LSX 1050

### Ordering – cable carrier

Cable carrier					
<b>LS 1050</b>	<b>180</b>	<b>RS 2</b>	<b>125</b>	<b>Sb</b>	<b>2415</b>
Type	Stay width B <sub>St</sub> in mm	Stay variant	Bend radius KR in mm	Chain band material	Chain length L <sub>k</sub> in mm (with- out connection)

#### Chain band materials:

Sb = specially coated steel  
ER 1 = stainless steel  
ER 1S = sea water resistant stainless steel

More information:  
See material overview on page 54.

### Ordering – divider system

Divider system	
<b>TS 0</b>	<b>4</b>
Divider system	Number of dividers n <sub>T</sub>

See also the sample order for the respective divider system.

### Ordering – connection

Connection					
<b>F</b>	<b>A</b>	<b>A</b>	<b>M</b>	<b>I</b>	<b>A</b>
Fixed point	Connection type	Connection surface	Driver	Connection type	Connection surface

If no order designation for the connection is stated, we supply the connection variant **FAI/MAI (Standard)**.

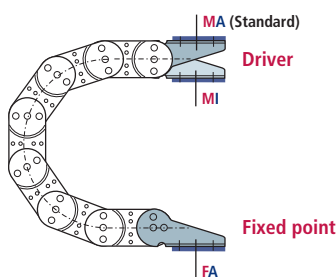

**F – Fixed point**  
**M – Driver**

**Connection type**  
**A** – Bolts facing outward (Standard)  
**I** – Bolts facing inward

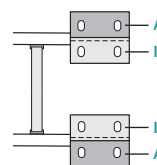

**Connection surface**  
**I** – Connector surface inside (< B<sub>k</sub>)  
**A** – Connector surface outside (> B<sub>k</sub>)

Guide channels  
➤ from page 166

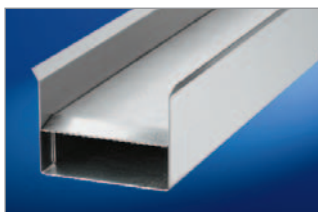

Strain relief devices  
➤ from page 173



Cables for cable carrier systems  
➤ in our TRAXLINE Cables for Motion Catalogue.



**LONG SERVICE LIFE**

Link design with special bolts for a long service life

**FLEXIBLE**

Various cable separation options

**VERSATILE**

Dividers of plastic or steel

**ROBUST**

Extremely robust chain bands, zinc plated or made of stainless steel

**STEEL**  
ZINC-PLATED

**STAINLESS STEEL**  
RUST-FREE

**INDIVIDUAL**

Different stay variants of aluminium or steel available in 1 mm section widths



**VARIABLE**

End connectors for different connection variants

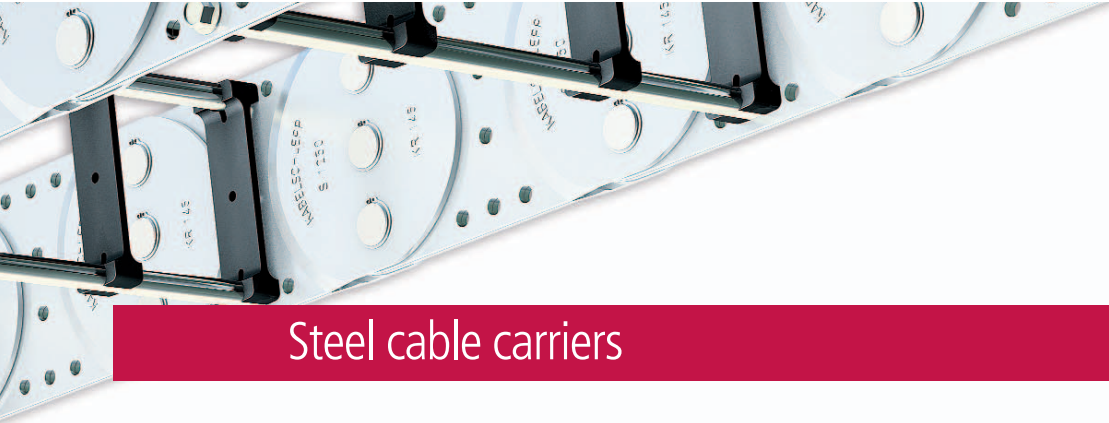

Steel cable carriers

# S Series

Chain bands made of zinc-plated steel

**STEEL**  
ZINC-PLATED

# SX Series

Chain bands made of rust and acid resistant steel

**STAINLESS  
STEEL**  
RUST-FREE

**Extremely robust and stable steel chains –  
for heavy mechanical loads and harsh environmental conditions**

Cable carriers tried and tested for many years with chain bands made of steel or stainless steel.

This makes the S/SX series very stable and robust:

- very stable chain link plates which each consist of two single plates
- link design with multiple stroke system and special bolts
- bolted stay system, solid end connectors



Further details about chain design can be found on page 26.

**Large unsupported lengths** and **high possible additional loads** are possible due to the extremely stable design. The link design with special bolts also makes simple shortening or lengthening of the chain possible. The installation of sectional parts on the construction site is also possible easily and quickly. The individual chain sections are connected together with the link bolts.

Covering the cable carrier with an aluminium cover system or steel band cover is possible for protecting the cables against hot chips or severe contamination.

Many stay variants with different stay cross sections and stay materials make possible an individual adaptation of the chain to the application and optimum laying of the cables and hoses.

## Overview of dimensions

Type	Height $h_i$	Chain width		Pitch $t$	Page
		$B_k$ min	$B_k$ max		
S/SX 0650	31	70	500	65	77
S/SX 0950	46	125	600	95	89
S/SX 1250	72	130	800	125	101
S/SX 1800	108	180	1000	180	121
S/SX 2500	183	250	1200	250	131
S/SX 3200	220	250	1500	320	137

Dimensions are dependent on the stay variant. Multi-band chains are possible for larger widths. See page 143 for values for types S/SX 5000-7000.





## Type S 0650

Steel chain bands

## Type SX 0650

Stainless steel chain bands

### Materials

Chain bands and end connectors:

**S 0650:** Steel, zinc-plated

**SX 0650:** grade rust and acid resistant steel

Standard stay material: aluminium alloy\*

Dividers and end pieces: plastic

→ see material properties, page 54

**STEEL**  
ZINC-PLATED  
**STAINLESS**  
STEEL  
RUST-FREE

### Chain width

customer-specific

available in 1 mm width sections



### Chain pitch

65 mm

### Bend radii

various **standard bend radii**

from 75 – 400 mm; intermediate radii upon request

\* See description for the respective stay variant for details.

2D/3D-Data  
kabelschlepp.de/cad-gb



### Stay variant RS

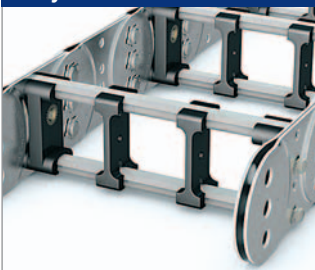

Clearance height  $h_j = 31 \text{ mm}$

➤ from page 79

### Stay variant RMA



Clearance height  $h_{j \text{ max}} = 200 \text{ mm}$

➤ from page 81

### Stay variant RR



Clearance height  $h_j = 26 \text{ mm}$

➤ from page 82

### Stay variant LG



max. hole  $\varnothing = 40 \text{ mm}$

➤ from page 83

### Stay variant RMD

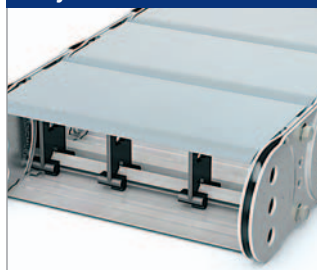

Clearance height  $h_j = 30 \text{ mm}$

➤ from page 84

# Type S 0650 / SX 0650

## Rolling schematic illustration unsupported arrangement

- Chain pitch  $t = 65 \text{ mm}$
- Height  $h_G = 50 \text{ mm}$
- Connection height  $H = 2 \text{ KR} + 75 \text{ mm}$  (unsupported)
- Connection length  $l_1 = 95/25 \text{ mm}$   
(see connection dimensions)

A flat and level surface is required for the cable carrier to extend and retract reliably. Under certain conditions, a support tray needs to be installed (see page 169).

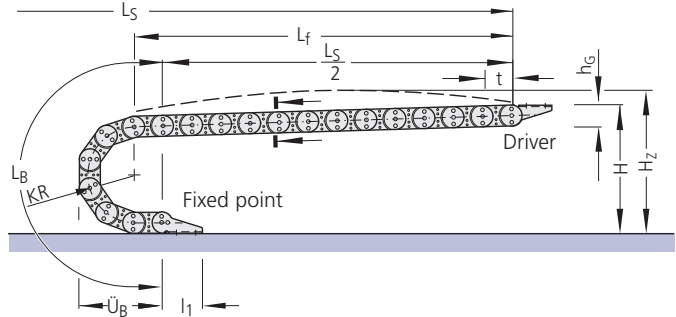

### Variable sizes

depending on the bend radius

Dimensions in mm

Bend radius	75	95	115	125	135	145	155	175	200	250	300	400
Bend length $L_B$	496	558	621	653	684	716	747	810	888	1045	1202	1516
Bend overhang $\ddot{U}_B$	230	250	270	280	290	300	310	330	355	405	455	555
Height $H$ (unsupported)	225	265	305	325	345	365	385	425	475	575	675	875

#### Chain length:

$$L_k \approx \frac{L_S}{2} + L_B$$

rounded to pitch 65 mm

#### Installation height\*:

$$H_Z = H + z$$

Pre-tension  $z \approx 10 \text{ mm/m}$  chain length  
\*required clear height

## Load diagramm

### Unsupported length $L_f$ and travel length $L_S$ without support

depending on the additional load (see design guidelines).

Load diagram for an intrinsic chain weight  $q_k$  of 4.5 kg/m.

If the intrinsic chain weight  $q_k$  of 4.5 kg/m is exceeded, the permissible additional load is reduced by the difference.

For circular operations, combinations of KR/RKR are possible. Please contact us for details.

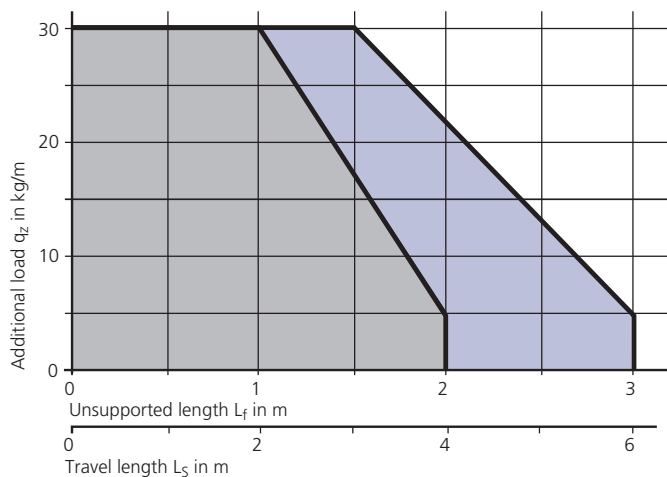

- S 0650 material zinc-plated steel
- SX 0650 material ER 2
- SX 0650 material ER 1 / ER 1S

## Type S 0650 / SX 0650

### Stay variant RS 2 – with bolted stays

- frame stay RS made of aluminium – standard design
- for lightweight to medium loads
- **Standard stay arrangement:** on every 2nd chain link. Stays can be fitted on every chain link, please specify when placing your order.
- bolted stays for maximum stability

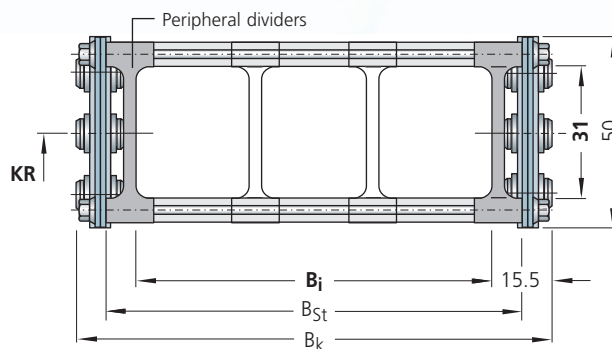
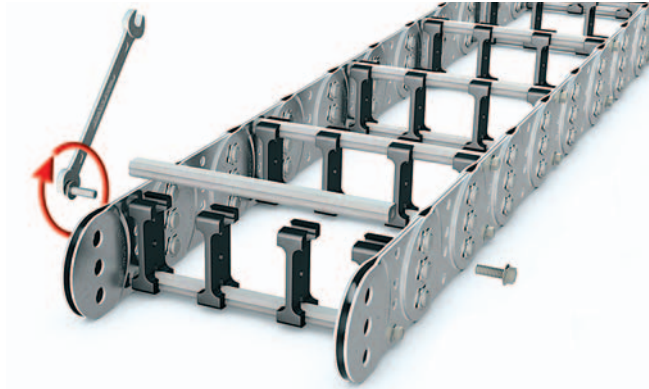

All chain cross sections according to sectional information in the schematic illustration.

The peripheral dividers are an integral part of the stay system and must not be ordered separately.

### Intrinsic chain weight

for two band chains  
depending on the chain width.

Weight of the chain bands:  
3.6 kg/m (excluding stays)

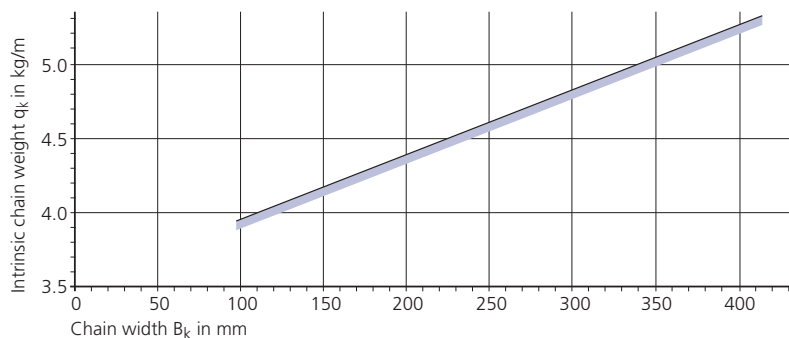

### Divider system TS 0 for stay variant RS 2

The dividers are **movable**.

$s_T$	= 3 mm
$a_{T \min}$	= 11.5 mm
$a_{x \min}$	= 13 mm

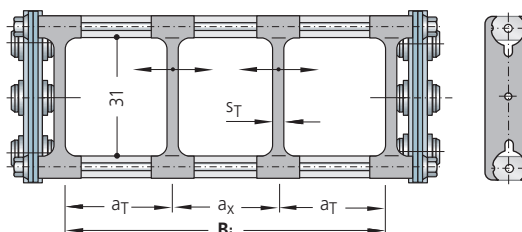

Example for ordering  
– divider system TS 0

TS 0	/	2
Divider system		Number of dividers nT

## Type S 0650 / SX 0650

### Stay variant RS 1 – with a detachable stay

- frame stay RS made of aluminium – solid design
- for lightweight to medium loads
- **Standard opening options:**
  - Outside:** The cable carrier can be opened quickly and easily simply by rotating the stays through 90°.
  - Inside:** Screwed stays
  - Optional:** Bolted on the outside and opening inwards, please state when ordering.
- **Standard stay arrangement:** on every 2nd chain link. Stays can be fitted on every chain link, please specify when placing your order.

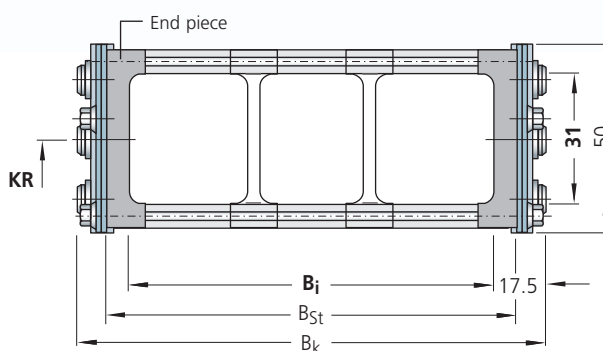
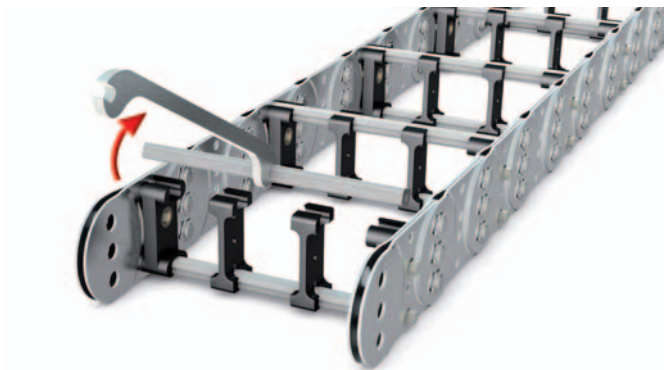

All chain cross sections according to sectional information in the schematic illustration.

The end pieces are an integral part of the stay system and must not be ordered separately.

#### Chain width:

$$B_k = B_i + 35 \text{ mm}$$

$$B_{k \text{ min}} = 100 \text{ mm}$$

$$B_{k \text{ max}} = 300 \text{ mm}$$

#### Stay width:

$$B_{St} = B_i + 20 \text{ mm}$$

$$B_{St} = B_k - 15 \text{ mm}$$

### Intrinsic chain weight

#### for two band chains

depending on the chain width.

Weight of the chain bands:

3.6 kg/m (excluding stays)

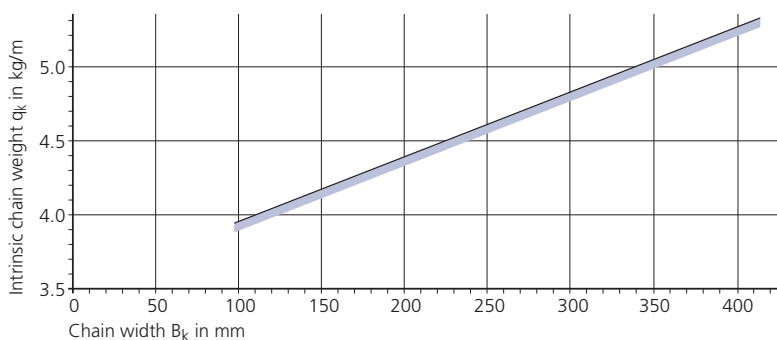

### Divider system TS 0 for stay variant RS 1

The dividers are **movable**.

$s_T$	= 3 mm
$a_T \text{ min}$	= 11.5 mm
$a_x \text{ min}$	= 13 mm

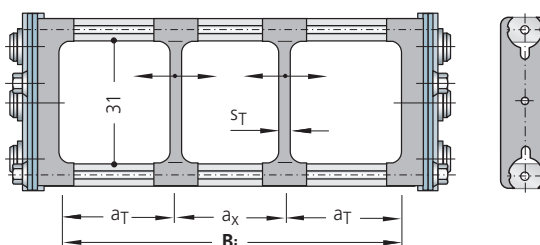

**Example for ordering – divider system TS 0**

<b>TS 0</b>	/	<b>2</b>
Divider system		Number of dividers $n_T$

## Type S 0650 / SX 0650

### Stay variant RMA – mounting frame stay

- for very large cable diameters such as with air hoses
- cables with diameters greater than the clearance height of the chain links can be routed
- installed on the inside or outside in the bend radius according to preference
- **Standard stay arrangement:**  
on every 2nd chain link.  
Stays can be fitted on every chain link, please specify when placing your order.
- bolted stays for maximum stability

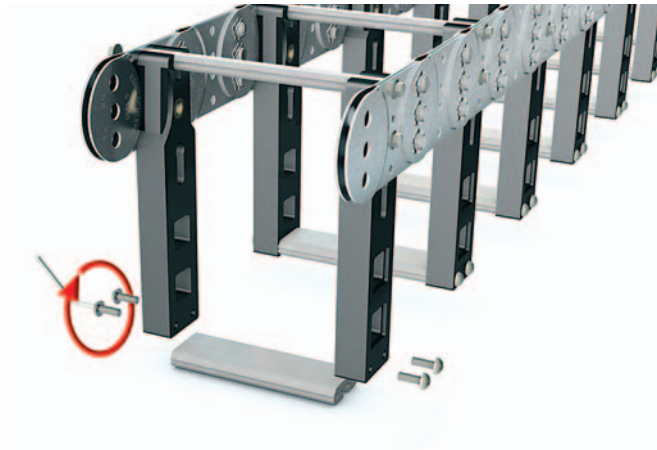

#### Chain width:

$$B_k = B_i + 45 \text{ mm}$$

$$B_{k \text{ min}} = 200 \text{ mm}$$

$$B_{k \text{ max}} = 400 \text{ mm}$$

#### Stay width:

$$B_{St} = B_i + 30 \text{ mm}$$

$$B_{St} = B_k - 15 \text{ mm}$$

#### Available passage heights:

$$H_i = 130, 160, 200 \text{ mm}$$

#### Assembly on the inside –

observe minimum bend radius  
(half-stayed arrangement):

$$H_i = 130 \text{ mm: } KR_{\text{min}} = 175 \text{ mm}$$

$$H_i = 160 \text{ mm: } KR_{\text{min}} = 220 \text{ mm}$$

$$H_i = 200 \text{ mm: } KR_{\text{min}} = 300 \text{ mm}$$

Minimum bend radius full-stayed –  
please ask us about it.

The cable carrier must be supported  
on the chain band and not on the stays.

### Intrinsic chain weight

#### for two band chains

depending on the chain width.

Weight of the chain bands:  
3.6 kg/m (excluding stays)

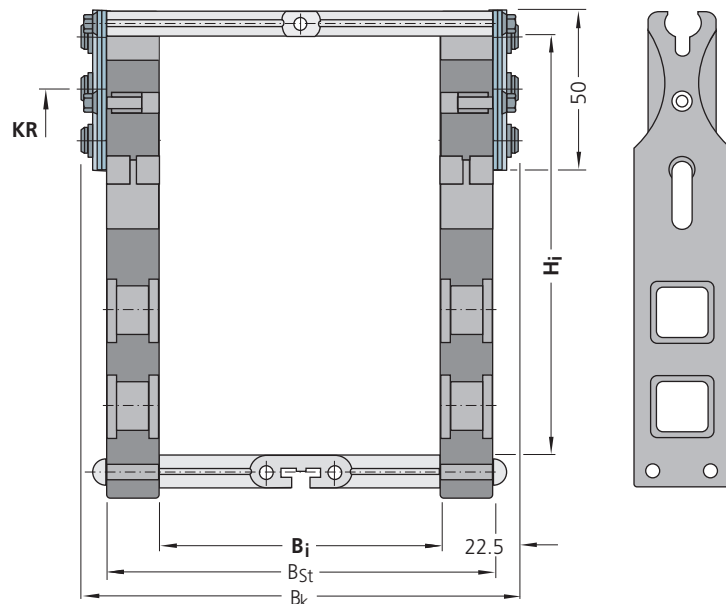

All chain cross sections according to the section information in the schematic illustration.

On account of the design parameters to be observed, we ask you to contact our technical consultants.

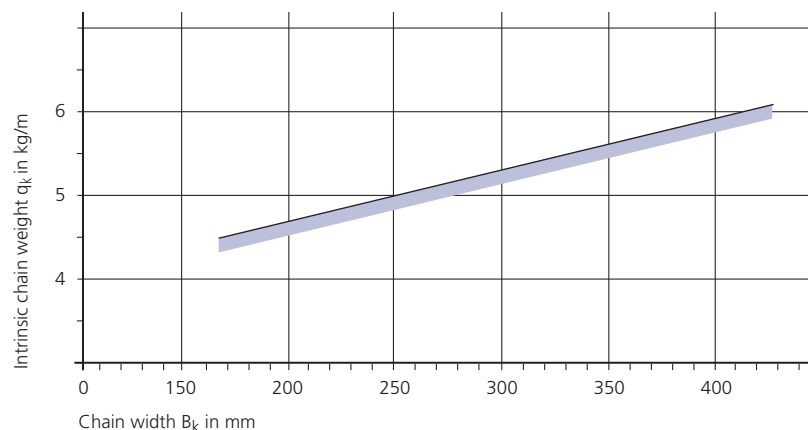

# Type S 0650 / SX 0650

## Stay variant RR – frame stay, tube design

- gentle cable support due to rotating metal tubes
- ideal when using media hoses with "soft" sheaths
- possible materials of the axles, tubes and dividers:
  - axles and tubes, zinc-plated steel with plastic dividers (**standard**)
  - axles, tubes and dividers made of zinc-plated steel
  - axles, tubes and dividers made of stainless steel ER 1, ER 1S
- Standard stay arrangement:** on every 2nd chain link. Stays can be fitted on every chain link, please specify when placing your order.
- bolted stays for maximum stability

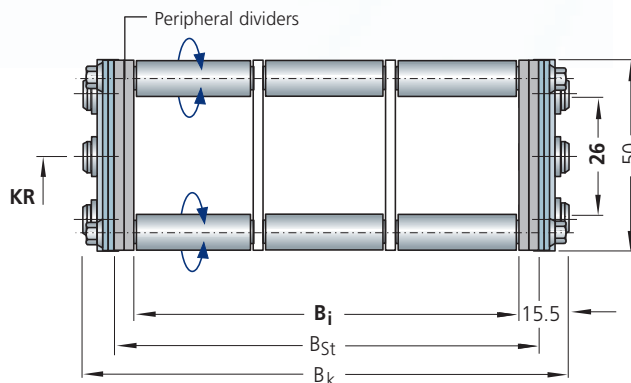
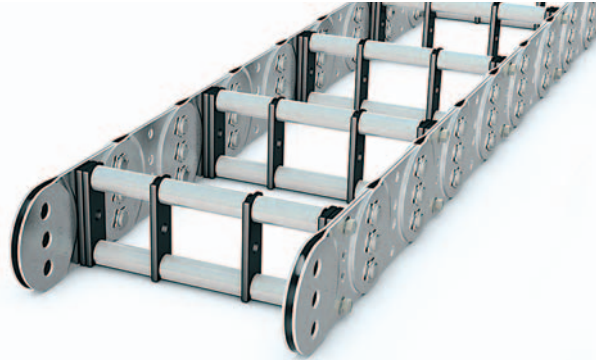

All chain cross sections according to sectional information in the schematic illustration.

The peripheral dividers are an integral part of the stay system and must not be ordered separately.

### Chain width:

$$B_k = B_i + 31 \text{ mm}$$

$$B_{k \text{ min}} = 100 \text{ mm}$$

$$B_{k \text{ max}} = 400 \text{ mm}$$

### Stay width:

$$B_{St} = B_i + 16 \text{ mm}$$

$$B_{St} = B_k - 15 \text{ mm}$$

## Intrinsic chain weight

for two band chains

depending on the chain width.

Weight of the chain bands:  
3.6 kg/m (excluding stays)

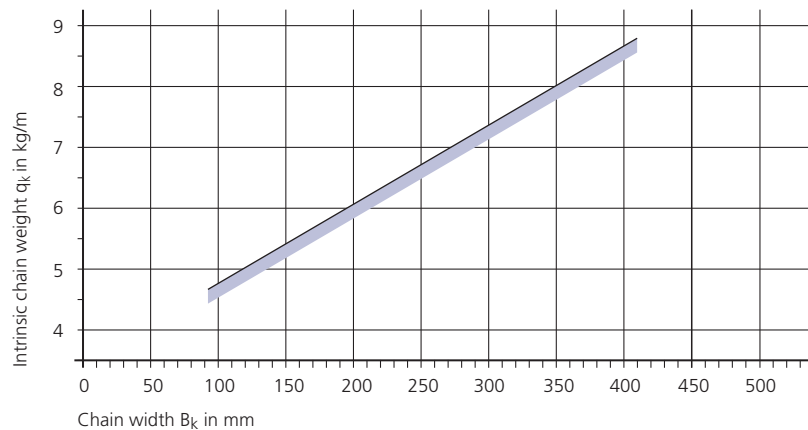

## Divider systems TS 0 and TS 1 for stay variant RR

The dividers are **fixed**.

**TS 0:** without height subdivision

**TS 1:** with continuous centric height subdivision

$s_T$	= 4 mm
$a_T \text{ min}$	= 20 mm
$a_x \text{ min}$	= 25 mm

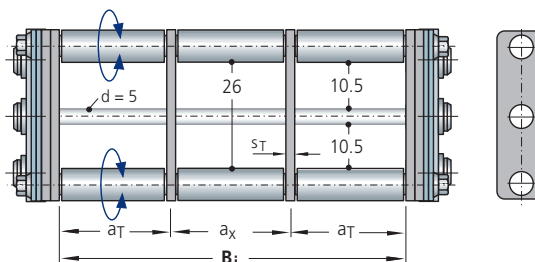

**Example for ordering – divider system**

<b>TS 0</b>	/	<b>2</b>
Divider system		Number of dividers $n_T$

Please state the dimensions  $a_T/a_x$  when ordering. Possibly enclose a sketch with dimensions.

## Type S 0650 / SX 0650

### Stay variant LG – hole stay made of aluminium, split design

- optimum cable guidance in the neutral bending line is possible
- drilling pattern individually adapted to the application
- high stability due to solid construction
- split design as standard for easy laying of the cables
- **Standard stay arrangement:**  
on every 2nd chain link.  
Stays can be fitted on every chain link, please specify when placing your order.
- bolted stays for maximum stability  
– also available not split

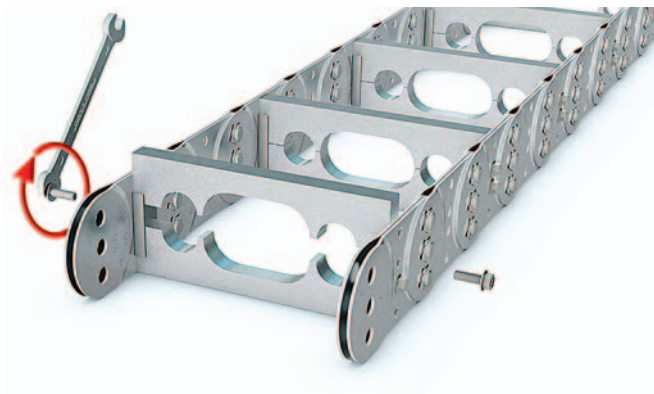

#### Chain width:

$$B_k = \sum D + \sum c + 35 \text{ mm}$$

$$B_{k \text{ min}} = 70 \text{ mm}$$

$$B_{k \text{ max}} = 500 \text{ mm}$$

#### Stay width:

$$B_{St} = \sum D + \sum c + 18 \text{ mm}$$

$$B_i = B_{St} - 2 a_0$$

$$B_{St} = B_k - 17 \text{ mm}$$

$$D_{\text{max}} = 40 \text{ mm}$$

$$c_{\text{min}} = 4 \text{ mm}$$

$$a_{0 \text{ min}} = 9 \text{ mm}$$

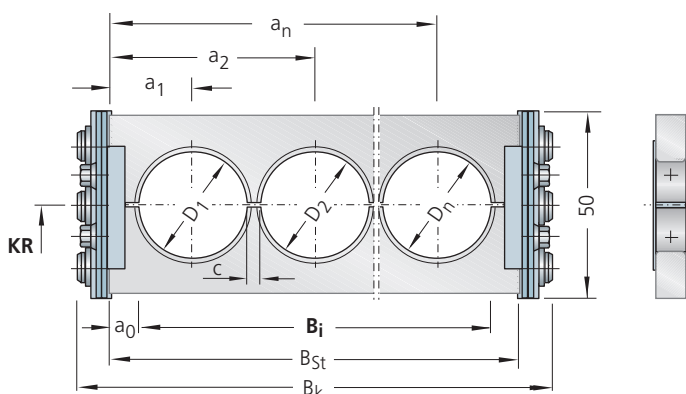

All chain cross sections according to sectional information in the schematic illustration.

### Intrinsic chain weight

#### for two band chains

depending on the chain width.

Hole area of the hole stay is approx. 50 %

Weight of the chain bands:  
3.6 kg/m (excluding stays)

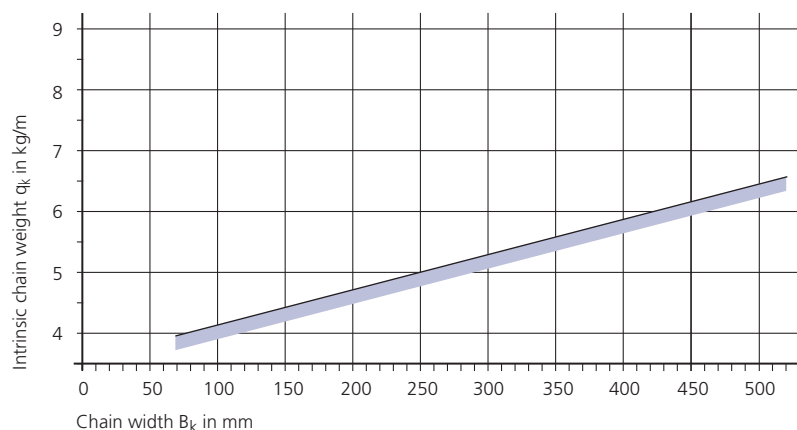

## Type S 0650 / SX 0650

### Stay variant RMD – covered cable carrier, STEEL-TUBE

- **aluminium cover system** for protecting the cables and hoses
- for applications where chips or severe contamination occur
- bolted aluminium cover for maximum stability

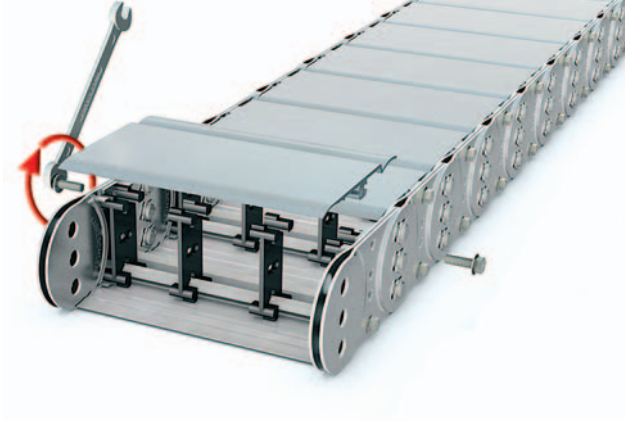

Steel band covers are also available as light-weight, economically priced alternatives to covering with the aluminium cover system, see page 172.



#### Chain width:

$$B_k = B_i + 35 \text{ mm}$$

$$B_{k \text{ min}} = 100 \text{ mm}$$

$$B_{k \text{ max}} = 500 \text{ mm}$$

#### Stay width:

$$B_{St} = B_i + 20 \text{ mm}$$

$$B_{St} = B_k - 15 \text{ mm}$$

#### Minimum bend radius

$$KR_{\text{min}} = 115 \text{ mm}$$

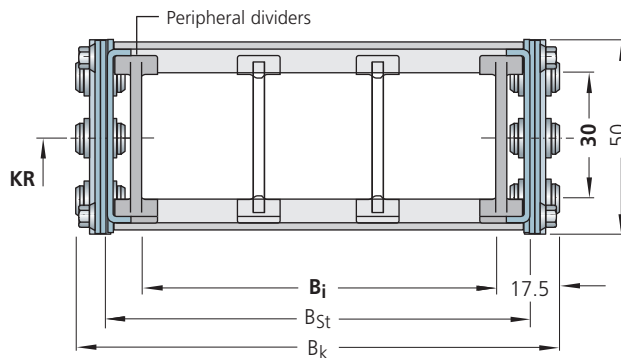

All chain cross sections according to sectional information in the schematic illustration.

The peripheral dividers are an integral part of the stay system and must not be ordered separately.

### Intrinsic chain weight

#### for two band chains

depending on the chain width.

Weight of the chain bands:  
3.6 kg/m (excluding stays)

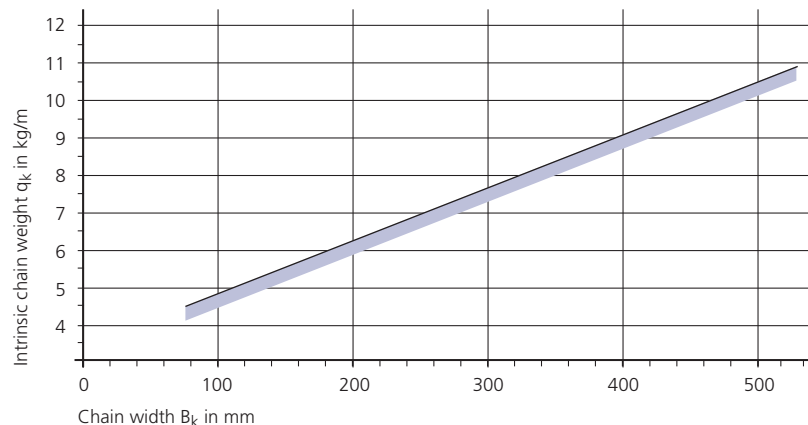



## Type S 0650 / SX 0650

### Stay variant RMD – covered cable carrier, STEEL-TUBE

#### Divider systems TS 0 and TS 1 for stay variant RMD

The dividers are **movable**.

**TS 0:** without height subdivision

**TS 1:** with continuous centric height subdivision

$s_T$	= 3 mm
$a_{T \text{ min}}$	= 11.5 mm
$a_{x \text{ min}}$	= 13 mm

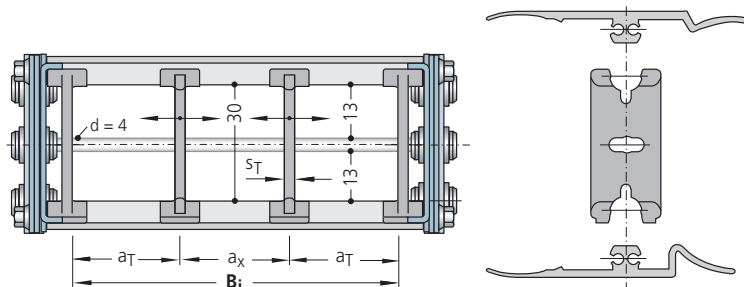

**Example for ordering – divider system**

<b>TS 0</b>	/	<b>2</b>
Divider system		Number of dividers $n_T$

# Type S 0650 / SX 0650

## Fixed point connection

### Connection variant FA

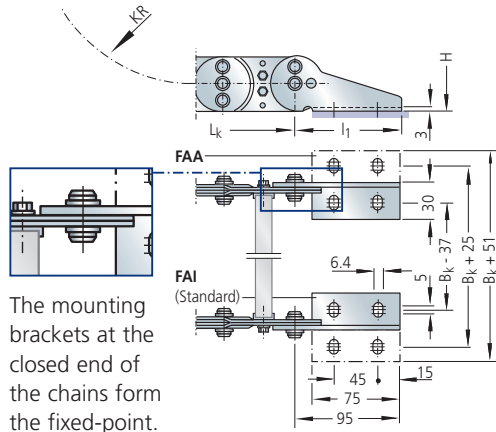

### Connection variant FI

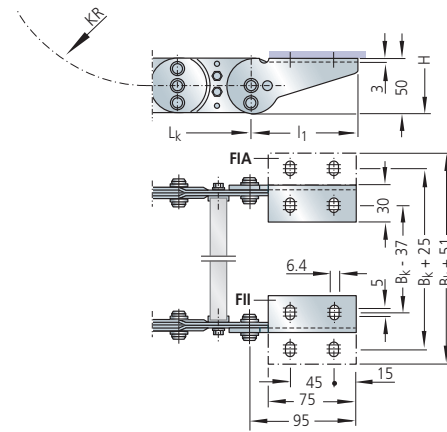

### Connection variant FH

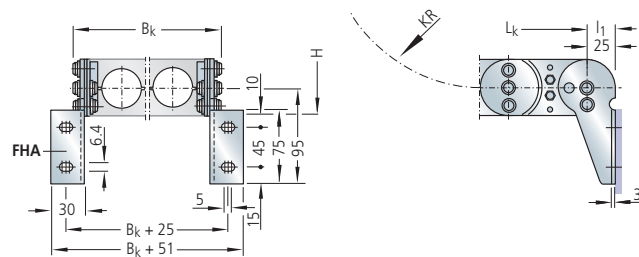

### Connection variant FK

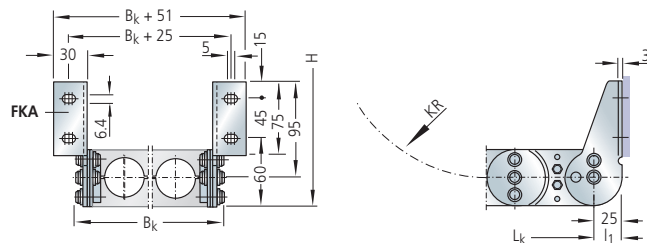

Different connection variants for fixed point and driver are possible according to the drawing information and are realized by different assembly of the connecting pieces.

The connection variants can also be changed at a later date if required.

Please state the desired connection variant according to the ordering key (see page 88).

## Type S 0650 / SX 0650

### Driver connection

#### Connection variant MA

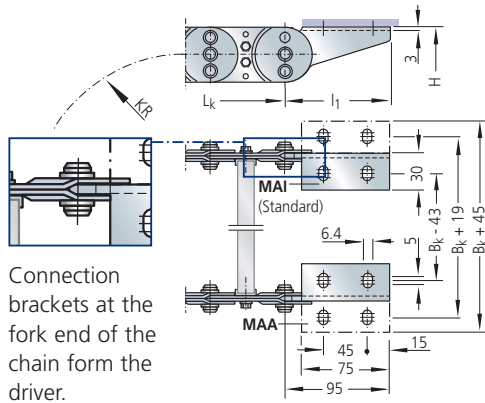

#### Connection variant MI

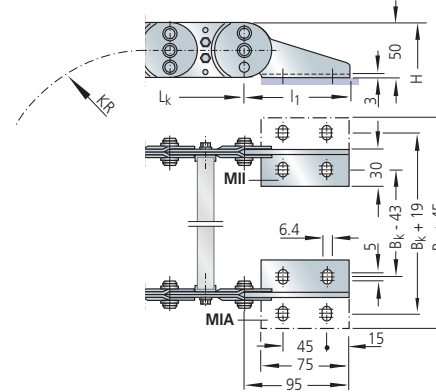

#### Connection variant MH

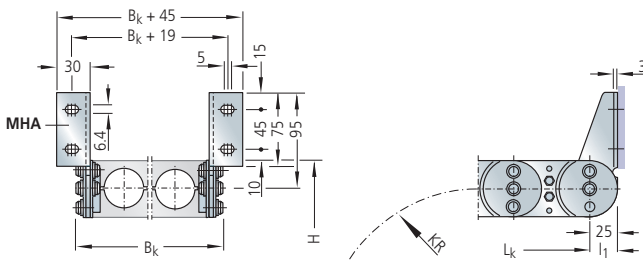

#### Connection variant MK

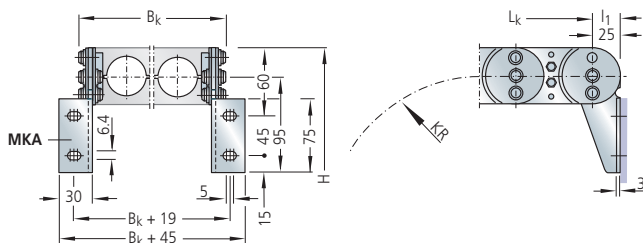

# Type S 0650 / SX 0650

## Ordering – cable carrier

Cable Carrier					
<b>S 0650</b>	<b>180</b>	<b>LG</b>	<b>135</b>	<b>St</b>	<b>1430</b>
Type	Stay width B <sub>St</sub> in mm	Stay variant	Bend radius KR in mm	Chain band material	Chain length L <sub>k</sub> in mm (with- out connection)

### Chain band materials:

- St = zinc-plated steel
- ER 1 = stainless steel
- ER 1S = sea water resistant stainless steel
- ER 2 = high-strength stainless steel

More information:  
See material overview on page 54.

## Ordering – divider system

Divider system	
<b>TS 0</b>	<b>4</b>
Divider system	Number of dividers n <sub>T</sub>

See also the sample order for the respective divider system.

## Ordering – connection

Connection					
<b>F</b>	<b>A</b>	<b>A</b>	<b>M</b>	<b>K</b>	<b>A</b>
Fixed point	Connection type	Connection surface	Driver	Connection type	Connection surface

If no order designation for the connection is stated, we supply the connection variant **FAI/MAI (Standard)**.

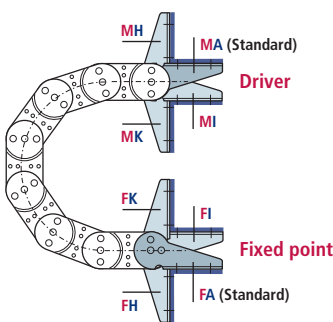

- F** – Fixed point
- M** – Driver

### Connection type

- A** – Bolts facing outward (Standard)
- I** – Bolts facing inward
- H** – Threaded joint, rotated by 90° to the outside
- K** – Threaded joint, rotated by 90° to the inside

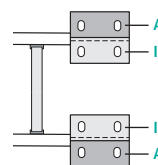

### Connection surface

- I** – Connector surface inside (< B<sub>k</sub>)
- A** – Connector surface outside (> B<sub>k</sub>)

The connecting surfaces on the driver and fixed point can be mounted on the outside or inside according to preference.

The connection type can easily be altered at a later date.

Guide channels  
➤ from page 166

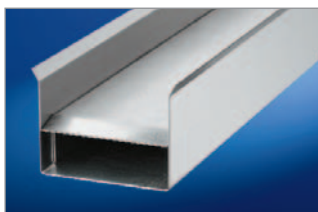

Strain relief devices  
➤ from page 173



Cables for cable carrier systems  
➤ in our TRAXLINE Cables for Motion catalogue.



## Type S 0950

Steel chain bands

## Type SX 0950

Stainless steel chain bands



2D/3D-Data  
[kabelschlepp.de/cad-gb](http://kabelschlepp.de/cad-gb)

### Materials

Chain bands and end connectors:

**S 0950:** Steel, zinc-plated

**SX 0950:** grade rust and acid resistant steel

Standard stay material: aluminium alloy\*

Dividers and end pieces: plastic

→ see material properties, page 54

**STEEL**  
ZINC-PLATED  
**STAINLESS**  
**STEEL**  
RUST-FREE

### Chain width

customer-specific

available in 1 mm width sections



### Chain pitch

95 mm

### Bend radii

various standard bend radii

from 125 – 600 mm; intermediate radii upon request

\* See description for the respective stay variant for details.

### Stay variant RS



Clearance height  $h_j = 46$  mm

➤ from page 91

### Stay variant RM

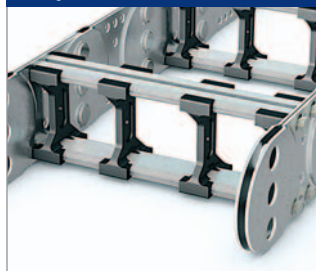

Clearance height  $h_j = 43$  mm

➤ from page 93

### Stay variant RMR



Clearance height  $h_j = 40$  mm

➤ from page 94

### Stay variant RR



Clearance height  $h_j = 42$  mm

➤ from page 95

### Stay variant LG



max. hole  $\varnothing = 48$  mm

➤ from page 96

### Stay variant RMD

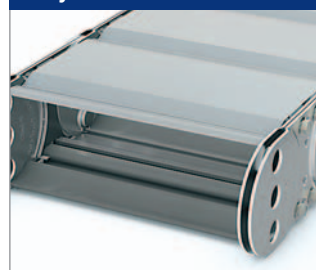

Clearance height  $h_j = 44$  mm

➤ from page 97

# Type S 0950 / SX 0950

## Rolling schematic illustration unsupported arrangement

- Chain pitch  $t = 95 \text{ mm}$
- Height  $h_G = 68 \text{ mm}$
- Connection height  $H = 2 \text{ KR} + 102 \text{ mm}$  (unsupported)
- Connection length  $l_1 = 125/34 \text{ mm}$  (see connection dimensions)

A flat and level surface is required for the cable carrier to extend and retract reliably.  
Under certain conditions, a support tray needs to be installed (see page 167).

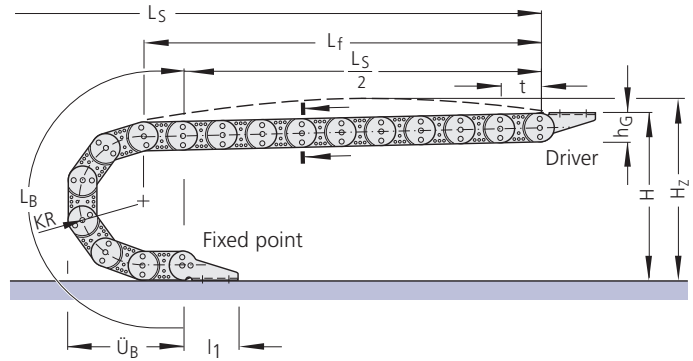

### Variable sizes

depending on the bend radius

Bend radius	Dimensions in mm									
	125	140	170	200	260	290	320	350	410	600
Bend length $L_B$	773	820	914	1008	1197	1291	1385	1480	1668	2264
Bend overhang $\ddot{U}_B$	350	365	395	425	485	515	545	575	635	825
Height $H$ (unsupported)	352	382	442	502	622	682	742	802	922	1302

#### Chain length:

$$L_k \approx \frac{L_s}{2} + L_B$$

rounded to pitch 95 mm

#### Installation height\*:

$$H_z = H + z$$

Pre-tension  $z \approx 10 \text{ mm/m}$  chain length  
\*required clear height

## Load diagramm

### Unsupported length $L_f$ and travel length $L_s$ without support

depending on the additional load (see design guidelines).

Load diagram for an intrinsic chain weight  $q_k$  of 7.6 kg/m.

If the intrinsic chain weight  $q_k$  of 7.6 kg/m is exceeded, the permissible additional load is reduced by the difference.

For circular operations, combinations of KR/RKR are possible.  
Please contact us for details.

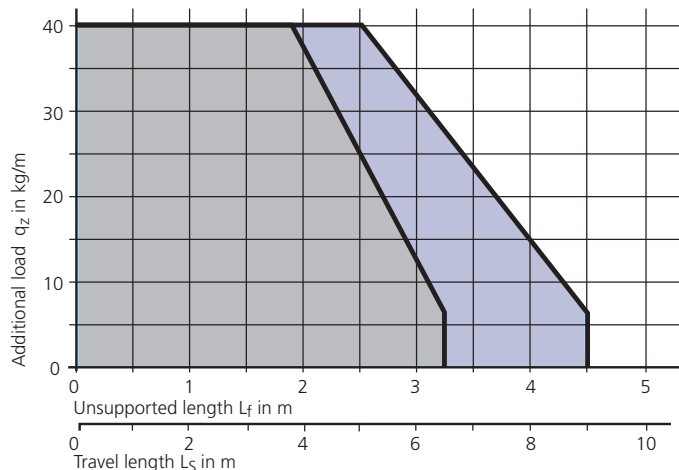

- S 0950 material zinc plated steel
- SX 0950 material ER 2
- SX 0950 material ER 1 / ER 1S

## Type S 0950 / SX 0950

### Stay variant RS 2 – with bolted stays

- frame stay RS made of aluminium – standard design
- for lightweight to medium loads
- **Standard stay arrangement:** on every 2nd chain link. Stays can be fitted on every chain link, please specify when placing your order.
- bolted stays for maximum stability

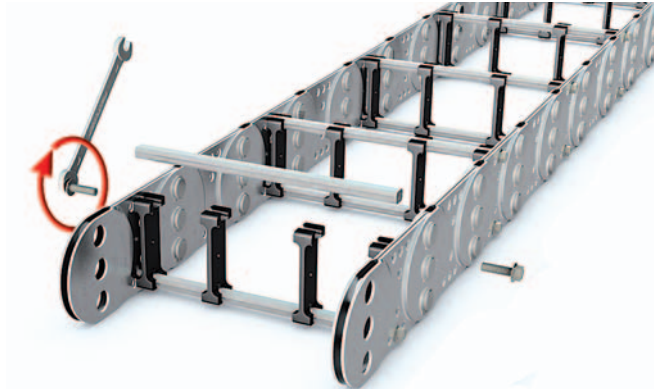

#### Chain width:

$$B_k = B_i + 37 \text{ mm}$$

$$B_k \text{ min} = 150 \text{ mm}$$

$$B_k \text{ max} = 400 \text{ mm}$$

#### Stay width:

$$B_{St} = B_i + 18 \text{ mm}$$

$$B_{St} = B_k - 19 \text{ mm}$$

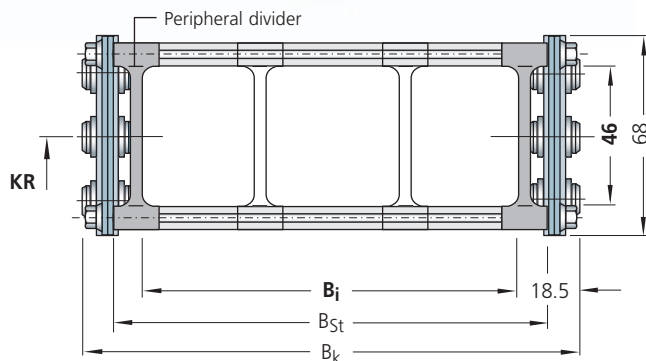

All chain cross sections according to sectional information in the schematic illustration.

The peripheral dividers are an integral part of the stay system and must not be ordered separately.

### Intrinsic chain weight

for two band chains

depending on the chain width.

Weight of the chain bands:

7.2 kg/m (excluding stays)

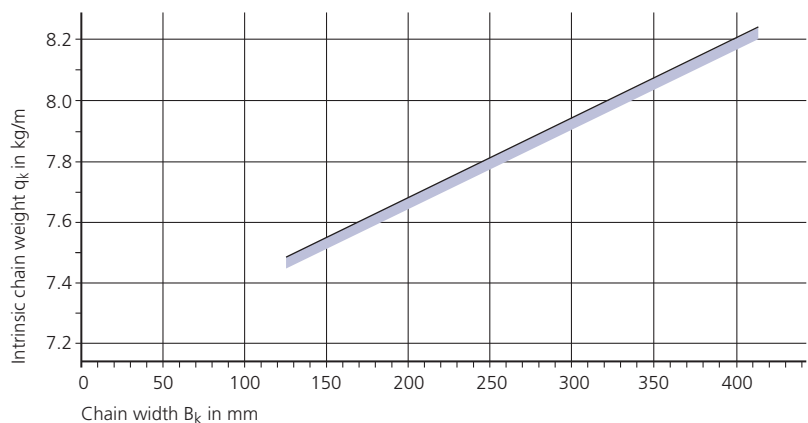

### Divider system TS 0 for stay variant RS 2

The dividers are **movable**.

$s_T$	= 4 mm
$a_T \text{ min}$	= 12 mm
$a_x \text{ min}$	= 14 mm

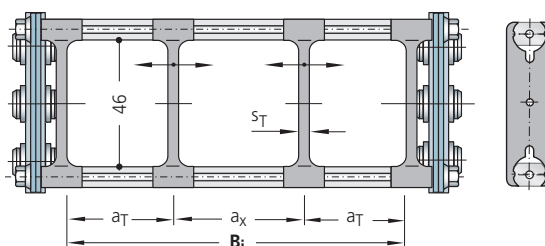

Example for ordering – divider system TS 0

<b>TS 0</b>	/	<b>2</b>
Divider system		Number of dividers $n_T$

# Type S 0950 / SX 0950

## Stay variant RS 1 – with a detachable stay

- frame stay RS made of aluminium – standard design
- for lightweight to medium loads
- **Standard opening options:**
  - Outside:** The cable carrier can be opened quickly and easily simply by rotating the stays through 90°.
  - Inside:** Screwed stays
  - Optional:** Bolted on the outside and opening inwards, please state when ordering.
- **Standard stay arrangement:** on every 2nd chain link. Stays can be fitted on every chain link, please specify when placing your order.

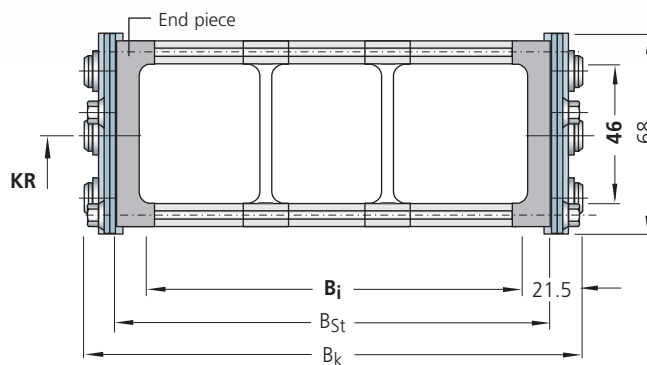

**All chain cross sections according to sectional information in the schematic illustration.**

The end pieces are an integral part of the stay system and must not be ordered separately.

### Chain width:

$$B_k = B_i + 43 \text{ mm}$$

$$B_k \text{ min} = 150 \text{ mm}$$

$$B_k \text{ max} = 300 \text{ mm}$$

### Stay width:

$$B_{St} = B_i + 24 \text{ mm}$$

$$B_{St} = B_k - 19 \text{ mm}$$

## Intrinsic chain weight

for two band chains

depending on the chain width.

Weight of the chain bands:  
7.2 kg/m (excluding stays)

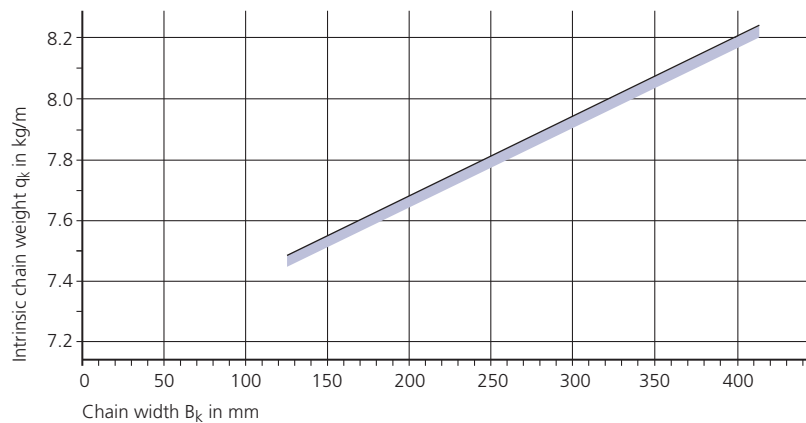

## Divider system TS 0 for stay variant RS 1

The dividers are **movable**.

$s_T$	= 4 mm
$a_T \text{ min}$	= 12 mm
$a_x \text{ min}$	= 14 mm

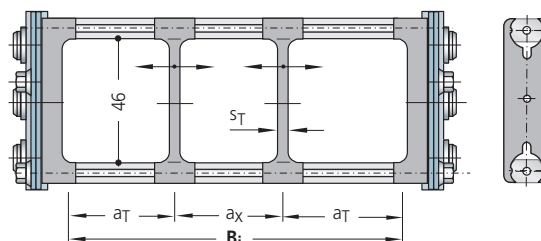

**Example for ordering – divider system TS 0**

<b>TS 0</b>	<b>/</b>	<b>2</b>
Divider system		Number of dividers nT



## Type S 0950 / SX 0950

### Stay variant RM – frame stay, solid design

- frame stay RM made of aluminium – solid design
- for heavy loads – maximum chain widths possible
- **Standard stay arrangement:** on every 2nd chain link. Stays can be fitted on every chain link, please specify when placing your order.
- bolted stays for maximum stability

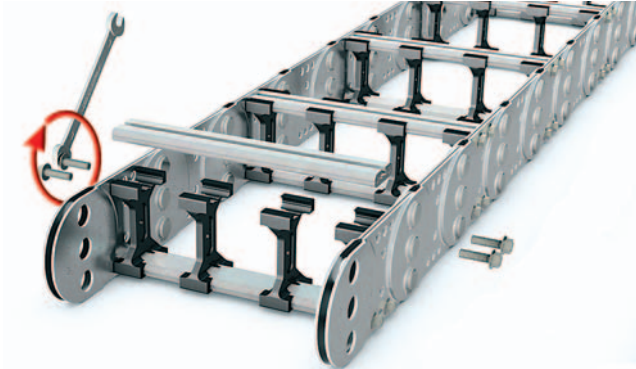

#### Chain width:

$$B_k = B_i + 37 \text{ mm}$$

$$B_k \text{ min} = 125 \text{ mm}$$

$$B_k \text{ max} = 600 \text{ mm}$$

#### Stay width:

$$B_{St} = B_i + 18 \text{ mm}$$

$$B_{St} = B_k - 19 \text{ mm}$$

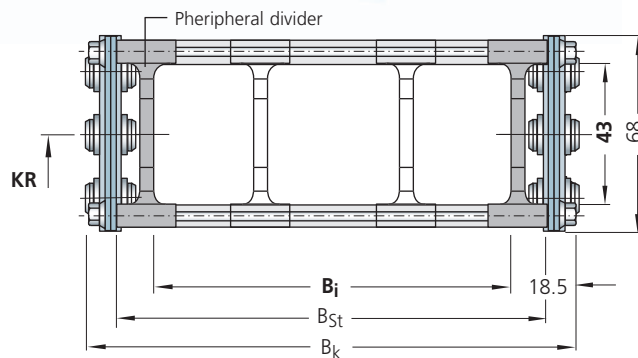

All chain cross sections according to sectional information in the schematic illustration.

The peripheral dividers are an integral part of the stay system and must not be ordered separately.

### Intrinsic chain weight

for two band chains

depending on the chain width.

Weight of the chain bands:  
7.2 kg/m (excluding stays)

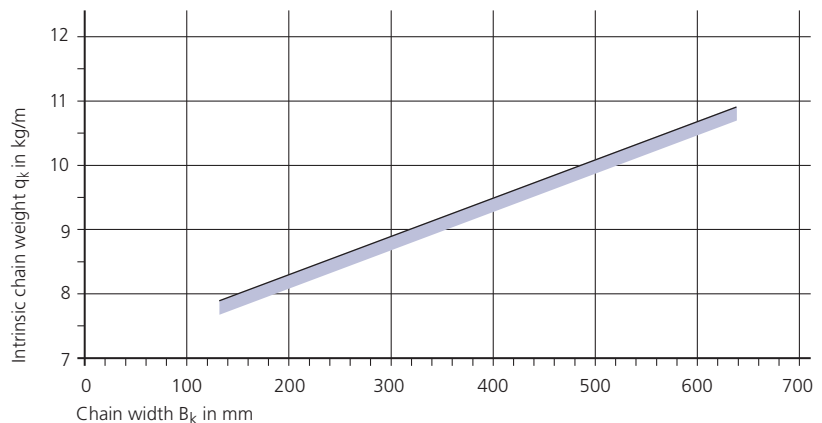

### Divider system TS 0 for stay variant RM

The dividers are **movable**.

$s_T$	= 4 mm
$a_{T \text{ min}}$	= 10 mm
$a_{x \text{ min}}$	= 14 mm

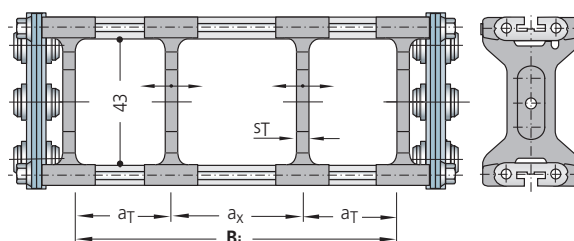

Example for ordering  
– divider system TS 0

<b>TS 0</b>	<b>2</b>
Divider system	Number of dividers $n_T$

# Type S 0950 / SX 0950

## Stay variant RMR – frame stay with plastic roller system

- gentle cable support due to rotatable plastic rollers
- ideal when using media hoses with "soft" sheaths
- stay profile made of aluminium – rollers made of plastic
- plastic dividers in roller version
- **Standard stay arrangement:**  
on every 2nd chain link.  
Stays can be fitted on every chain link, please specify when placing your order.
- bolted stays for maximum stability

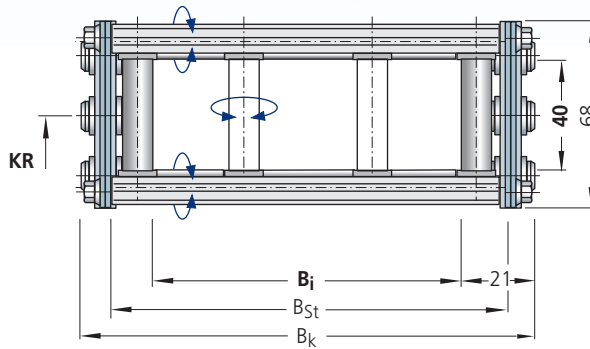
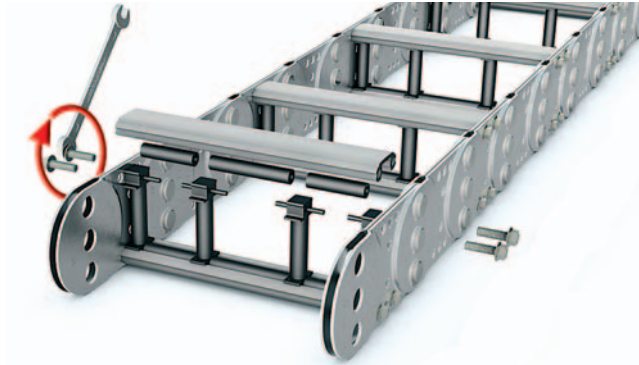

All chain cross sections according to the section information in the schematic illustration.

### Chain width:

$$B_k = B_i + 42 \text{ mm}$$

$$B_{k \text{ min}} = 150 \text{ mm}$$

$$B_{k \text{ max}} = 600 \text{ mm}$$

### Stay width:

$$B_{St} = B_i + 23 \text{ mm}$$

$$B_{St} = B_k - 19 \text{ mm}$$

## Intrinsic chain weight

### for two band chains

depending on the chain width.

Weight of the chain bands:  
7.2 kg/m (excluding stays)

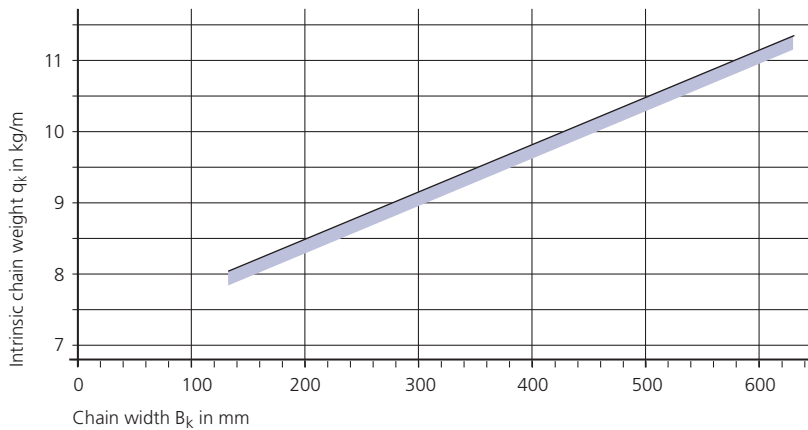

## Divider system TS 0 for stay variant RMR

The standard dividers are **fixed**.

Moveable dividers ( $s_T = 4 \text{ mm}$ ) can be used as an option. Please specify when placing your order.

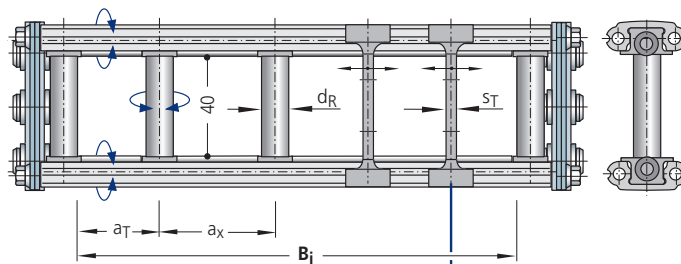

### Example for ordering – divider system TS 0

<b>TS 0</b>	/	<b>2</b>
Divider system		Number of dividers $n_T$

Please state the dimensions  $a_T/a_x$  when ordering. Possibly enclose a sketch with dimensions.

$d_R$	= 10 mm
$a_T \text{ min}$	= 11.5 mm
$a_x \text{ min}$	= 37 mm

## Type S 0950 / SX 0950

### Stay variant RR – frame stay, tube design

- gentle cable support due to rotating metal tubes
- ideal when using media hoses with "soft" sheaths
- possible materials of the axles, tubes and dividers:
  - axles, zinc-plated steel with plastic dividers (**Standard**)
  - axles and dividers made of zinc-plated steel
  - axles and dividers made of stainless steel ER 1, ER 1S

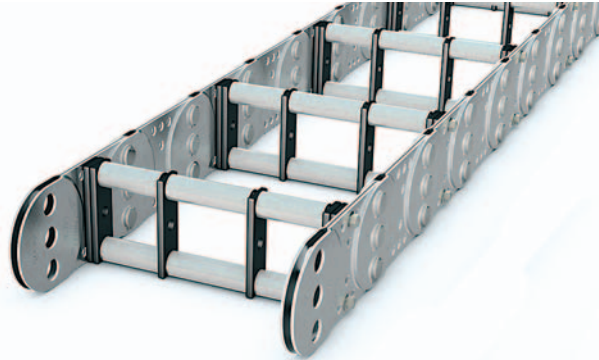

- Standard stay arrangement:** on every 2nd chain link. Stays can be fitted on every chain link, please specify when placing your order.
- bolted stays for maximum stability

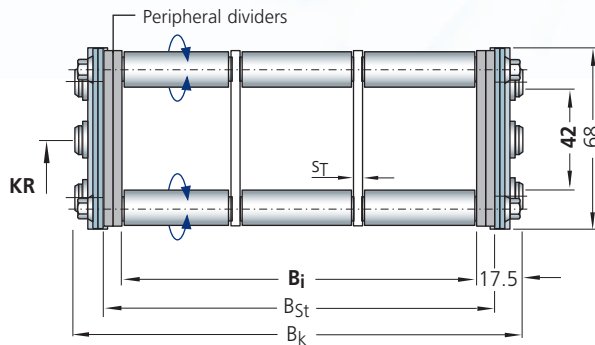

#### Chain width:

$$B_k = B_i + 35 \text{ mm}$$

$$B_{k \text{ min}} = 150 \text{ mm}$$

$$B_{k \text{ max}} = 500 \text{ mm}$$

#### Stay width:

$$B_{St} = B_i + 16 \text{ mm}$$

$$B_{St} = B_k - 19 \text{ mm}$$

### Intrinsic chain weight

#### for two band chains

depending on the chain width.

Weight of the chain bands:  
7.2 kg/m (excluding stays)

All chain cross sections according to sectional information in the schematic illustration.

The peripheral dividers are an integral part of the stay system and must not be ordered separately.

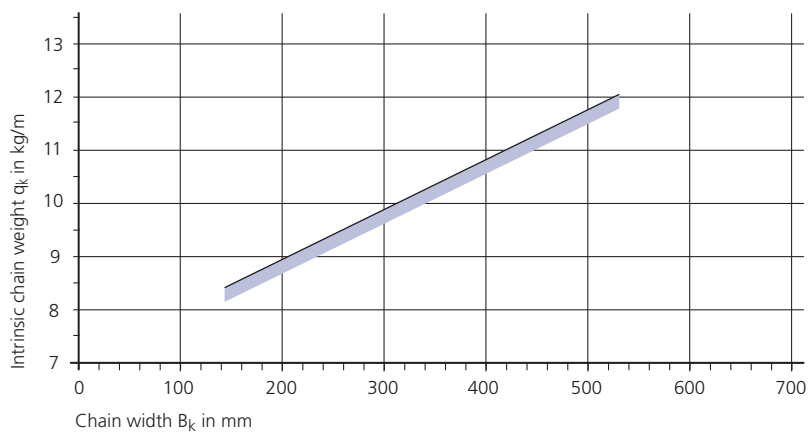

### Divider systems TS 0 and TS 1 for stay variant RR

The dividers are **fixed**.

**TS 0:** without height subdivision

**TS 1:** with continuous centric height subdivision

$s_T$	= 4 mm
$a_T \text{ min}$	= 20 mm
$a_X \text{ min}$	= 20 mm

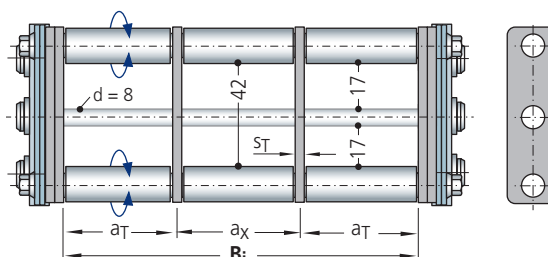

#### Example for ordering – divider system

<b>TS 0</b>	/	<b>2</b>
Divider system		Number of dividers $n_T$

Please state the dimensions  $a_T/a_X$  when ordering. Possibly enclose a sketch with dimensions.

## Type S 0950 / SX 0950

### Stay variant LG – hole stay made of aluminium, split design

- optimum cable guidance in the neutral bending line is possible
- drilling pattern individually adapted to the application
- high stability due to solid construction
- split design as standard for easy laying of the cables
- **Standard stay arrangement:**  
on every 2nd chain link.  
Stays can be fitted on every chain link, please specify when placing your order.
- bolted stays for maximum stability  
– also available not split

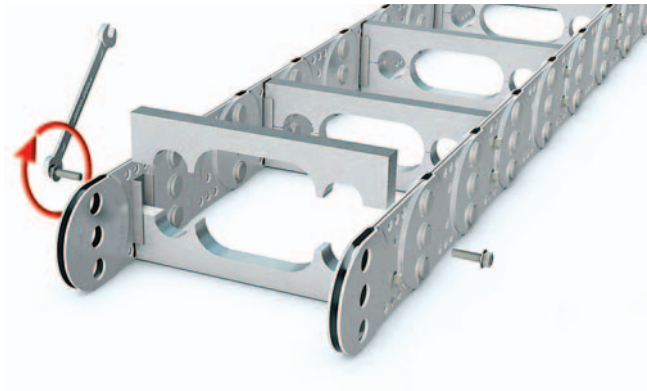

#### Chain width:

$$B_k = \sum D + \sum c + 43 \text{ mm}$$

$$B_k \text{ min} = 125 \text{ mm}$$

$$B_k \text{ max} = 600 \text{ mm}$$

#### Stay width:

$$B_{St} = \sum D + \sum c + 22 \text{ mm}$$

$$B_i = B_{St} - 2 a_0$$

$$B_{St} = B_k - 21 \text{ mm}$$

$$D_{\text{max}} = 48 \text{ mm}$$

$$c_{\text{min}} = 4 \text{ mm}$$

$$a_{0 \text{ min}} = 11 \text{ mm}$$

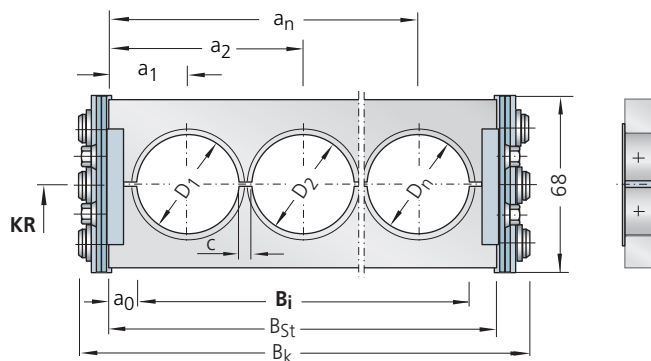

All chain cross sections according to sectional information in the schematic illustration.

### Intrinsic chain weight

#### for two band chains

depending on the chain width.

Hole area of the hole stay is approx. 50 %

Weight of the chain bands:

7.2 kg/m (excluding stays)

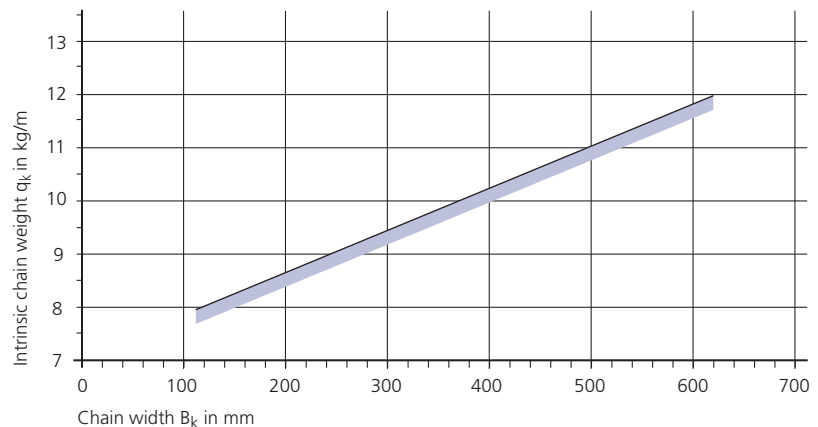

## Type S 0950 / SX 0950

### Stay variant RMD – covered cable carrier, STEEL-TUBE

- **aluminium cover system** for protecting the cables and hoses
- for applications where chips or severe contamination occur
- bolted aluminium cover for maximum stability

Steel band covers are also available as light-weight, economically priced alternatives to covering with the aluminium cover system, see page 172.

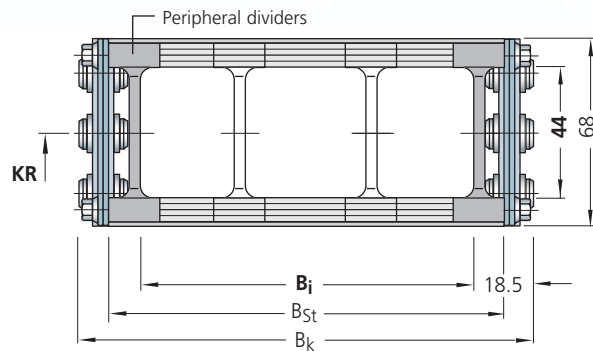
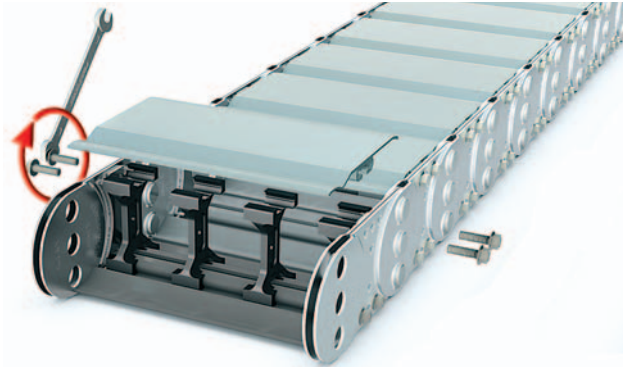

#### Chain width:

$$B_k = B_i + 37 \text{ mm}$$

$$B_{k \text{ min}} = 125 \text{ mm}$$

$$B_{k \text{ max}} = 600 \text{ mm}$$

#### Stay width:

$$B_{St} = B_i + 18 \text{ mm}$$

$$B_{St} = B_k - 19 \text{ mm}$$

#### Minimum bend radius

$$KR_{\text{min}} = 170 \text{ mm}$$

#### Intrinsic chain weight

##### for two band chains

depending on the chain width.

Weight of the chain bands:  
7.2 kg/m (excluding stays)

All chain cross sections according to sectional information in the schematic illustration.

The peripheral dividers are an integral part of the stay system and must not be ordered separately.

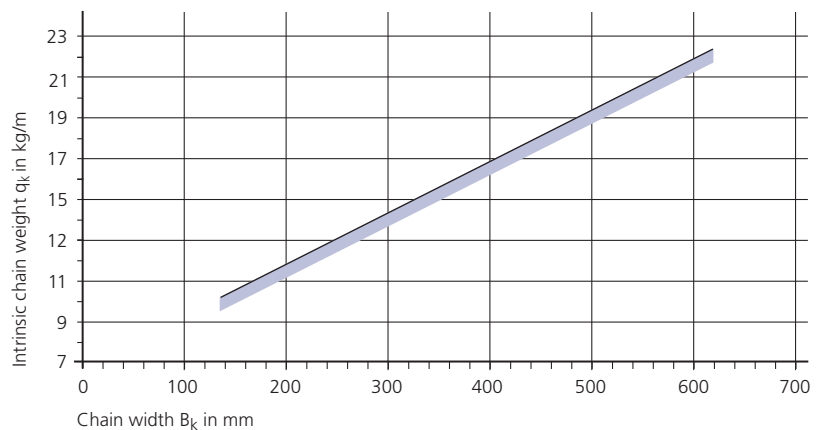

### Divider system TS 0 for stay variant RMD

The dividers are **movable**.

$s_T$	= 4 mm
$a_{T \text{ min}}$	= 12 mm
$a_{x \text{ min}}$	= 14 mm

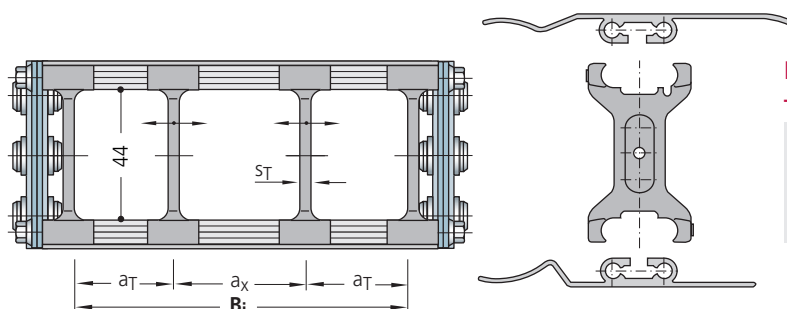

Example for ordering – divider system TS 0

TS 0	/	2
Divider system		Number of dividers $n_T$

# Type S 0950 / SX 0950

## Fixed point connection

### Connection variant FA

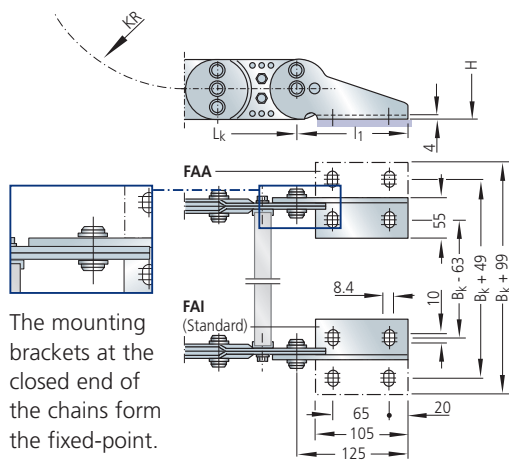

The mounting brackets at the closed end of the chains form the fixed-point.

### Connection variant FI

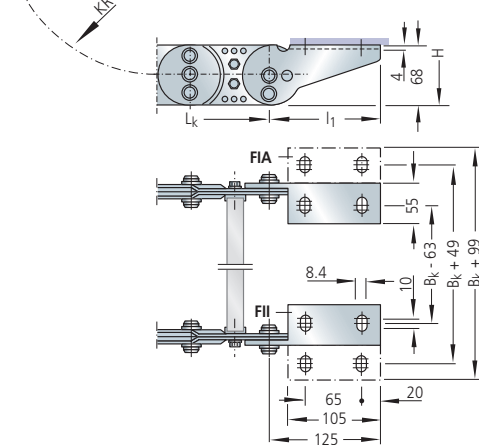

### Connection variant FH

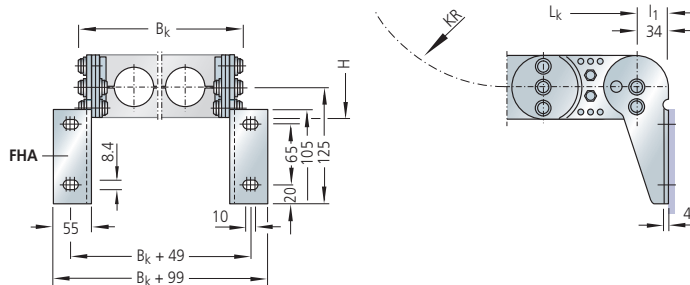

### Connection variant FK

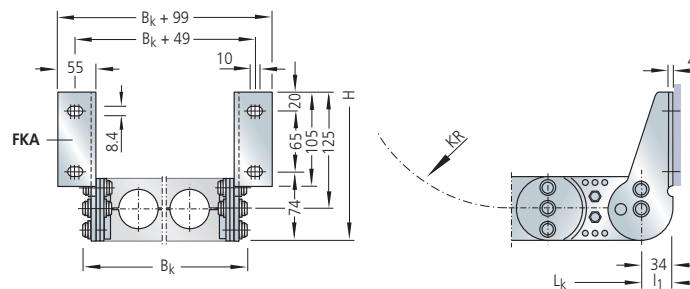

Different connection variants for fixed point and driver are possible according to the drawing information and are realized by different assembly of the connecting pieces.

The connection variants can also be changed at a later date if required.

Please state the desired connection variant according to the ordering key (see page 100).

### Type S 0950 / SX 0950

#### Driver connection

##### Connection variant MA

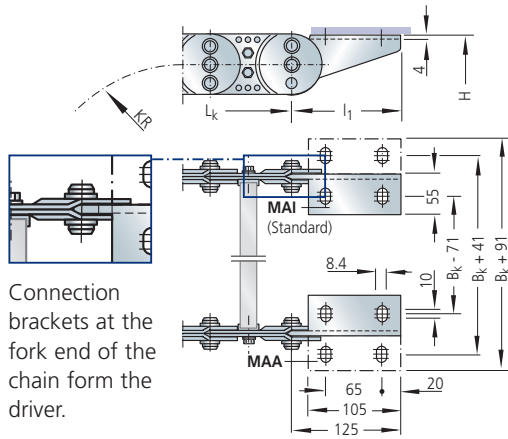

Connection brackets at the fork end of the chain form the driver.

##### Connection variant MI

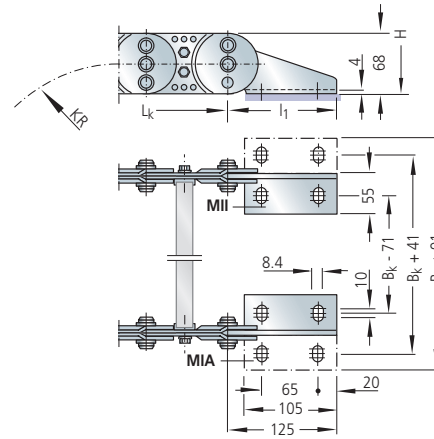

##### Connection variant MH

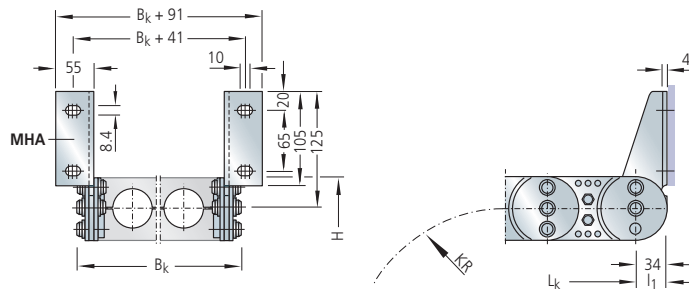

##### Connection variant MK

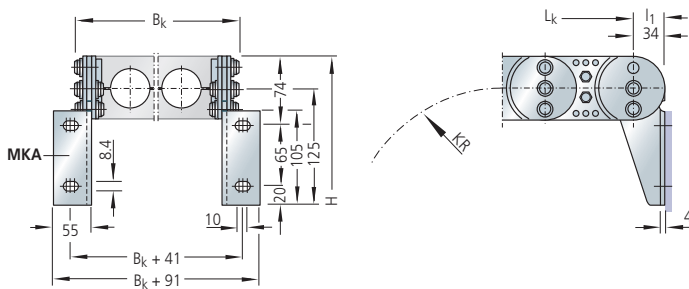

# Type S 0950 / SX 0950

## Ordering – cable carrier

Cable Carrier					
<b>S 0950</b>	<b>300</b>	<b>RS 1</b>	<b>200</b>	<b>St</b>	<b>2375</b>
Type	Stay width B <sub>St</sub> in mm	Stay variant	Bend radius KR in mm	Chain band material	Chain length L <sub>k</sub> in mm (with- out connection)

### Chain band materials:

- St = zinc-plated steel
- ER 1 = stainless steel
- ER 1S = sea water resistant stainless steel
- ER 2 = high-strength stainless steel

More information:  
See material overview on page 54.

## Ordering – divider system

Divider system	
<b>TS 0</b>	<b>4</b>
Divider system	Number of dividers n <sub>T</sub>

See also the sample order for the respective divider system.

## Ordering – connection

Connection					
<b>F</b>	<b>A</b>	<b>A</b>	<b>M</b>	<b>K</b>	<b>A</b>
Fixed point	Connection type	Connection surface	Driver	Connection type	Connection surface

If no order designation for the connection is stated, we supply the connection variant **FAI/MAI (Standard)**.

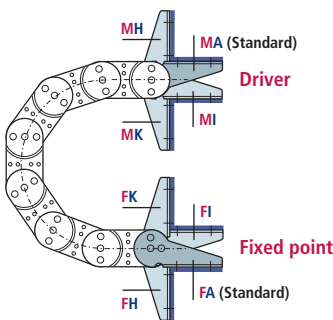

- F** – Fixed point
- M** – Driver
- Connection type**
- A** – Bolts facing outward (Standard)
- I** – Bolts facing inward
- H** – Threaded joint, rotated by 90° to the outside
- K** – Threaded joint, rotated by 90° to the inside

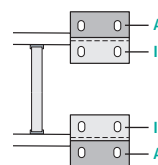

- Connection surface**
- I** – Connector surface inside (< B<sub>k</sub>)
- A** – Connector surface outside (> B<sub>k</sub>)

The connecting surfaces on the driver and fixed point can be mounted on the outside or inside according to preference.

The connection type can easily be altered at a later date.

Guide channels  
➤ from page 166

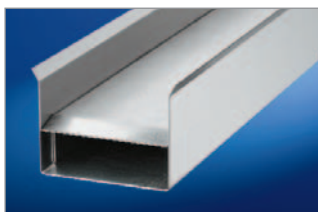

Strain relief devices  
➤ from page 173



Cables for cable carrier systems  
➤ in our TRAXLINE Cables for Motion catalogue.





## Type S 1250

Steel chain bands

## Type SX 1250

Stainless steel chain bands



2D/3D-Data  
[kabelschlepp.de/cad-gb](http://kabelschlepp.de/cad-gb)

### Materials

Chain bands and end connectors:

**S 1250:** Steel, zinc-plated

**SX 1250:** grade rust and acid resistant steel

Standard stay material: aluminium alloy\*

Dividers and end pieces: plastic

→ see material properties, page 54

**STEEL**  
ZINC-PLATED  
**STAINLESS**  
**STEEL**  
RUST-FREE

### Chain width

customer-specific

available in 1 mm width sections

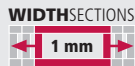

### Chain pitch

125 mm

### Bend radii

various standard bend radii

from 145 – 1000 mm; intermediate radii upon request

\* See description for the respective stay variant for details.

Also available with straight link plates: Type S/SX 1252 – please contact us!

### Stay variant RS



Clearance height  $h_j = 72$  mm

► from page 103

### Stay variant RV

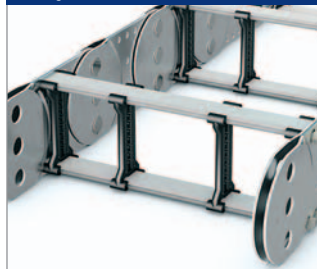

Clearance height  $h_j = 72$  mm

► from page 105

### Stay variant RM



Clearance height  $h_j = 69$  mm

► from page 109

### Stay variant RMA



Clearance height  $h_{j \max} = 200$  mm

► from page 112

### Stay variant RMR



Clearance height  $h_j = 66$  mm

► from page 113

### Stay variant RR



Clearance height  $h_j = 66$  mm

► from page 114

### Stay variant LG

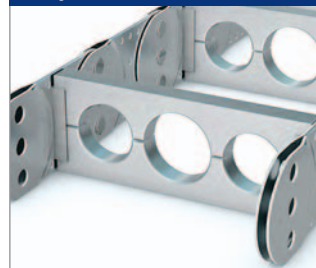

max. hole  $\varnothing = 74$  mm

► from page 115

### Stay variant RMD



Clearance height  $h_j = 69$  mm

► from page 116

# Type S 1250 / SX 1250

## Rolling schematic illustration unsupported arrangement

- Chain pitch  $t = 125 \text{ mm}$
- Height  $h_G = 94 \text{ mm}$
- Connection height  $H = 2 \text{ KR} + 141 \text{ mm}$  (unsupported)
- Connection length  $l_1 = 155/47 \text{ mm}$  (see connection dimensions)

A flat and level surface is required for the cable carrier to extend and retract reliably.  
Under certain conditions, a support tray needs to be installed (see page 169).

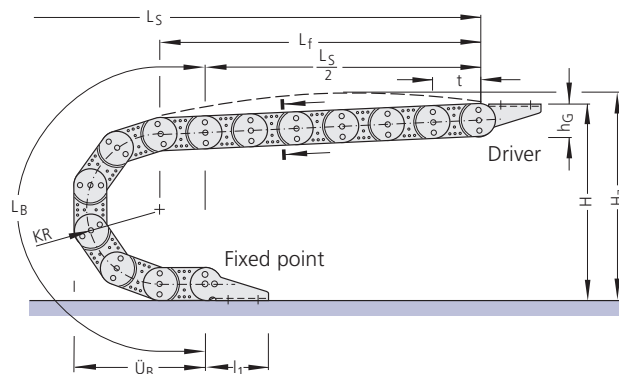

### Variable sizes

depending on the bend radius

Bend radius	Dimensions in mm												
	145	200	220	260	300	340	380	420	460	500	540	600	1000
Bend length $L_B$	955	1128	1191	1317	1442	1568	1694	1820	1945	2071	2196	2385	3640
Bend overhang $\ddot{U}_B$	442	497	517	557	597	637	677	717	757	797	837	897	1297
Height $H$ (unsupported)	431	541	581	661	741	821	901	981	1061	1141	1221	1341	2141

**Chain length:**  

$$L_k \approx \frac{L_s}{2} + L_B$$

rounded to pitch 125 mm

**Installation height\*:**  

$$H_z = H + z$$

Pre-tension  $z \approx 10 \text{ mm/m}$  chain length  
 \*required clear height

## Load diagramm

**Unsupported length  $L_f$  and travel length  $L_s$  without support** depending on the additional load (see design guidelines).

Load diagram for an intrinsic chain weight  $q_k$  of 13 kg/m.

If the intrinsic chain weight  $q_k$  of 13 kg/m is exceeded, the permissible additional load is reduced by the difference.

For circular operations, combinations of KR/RKR are possible. Please contact us for details.

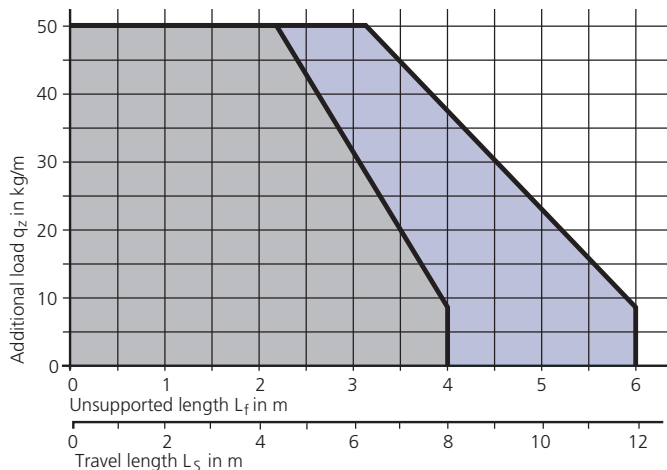

- S 1250 material zinc-plated steel
- SX 1250 material ER 2
- SX 1250 material ER 1 / ER 1S

## Type S 1250 / SX 1250

### Stay variant RS 2 – with bolted stays

- frame stay RS made of aluminium – standard design
- for lightweight to medium loads
- **Standard stay arrangement:** on every 2nd chain link. Stays can be fitted on every chain link, please specify when placing your order.
- bolted stays for maximum stability

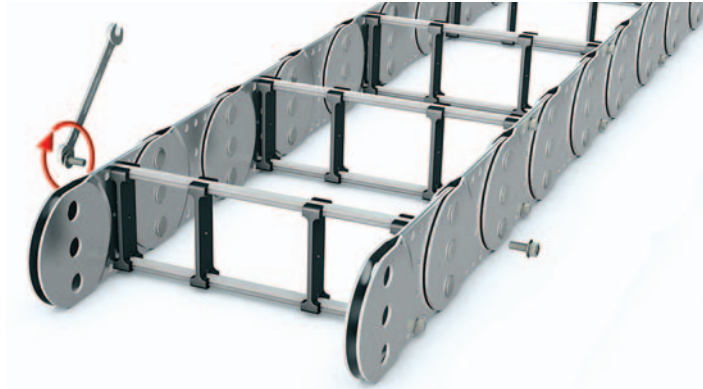

#### Chain width:

$$B_k = B_i + 44 \text{ mm}$$

$$B_k \text{ min} = 200 \text{ mm}$$

$$B_k \text{ max} = 500 \text{ mm}$$

#### Stay width:

$$B_{St} = B_i + 20 \text{ mm}$$

$$B_{St} = B_k - 24 \text{ mm}$$

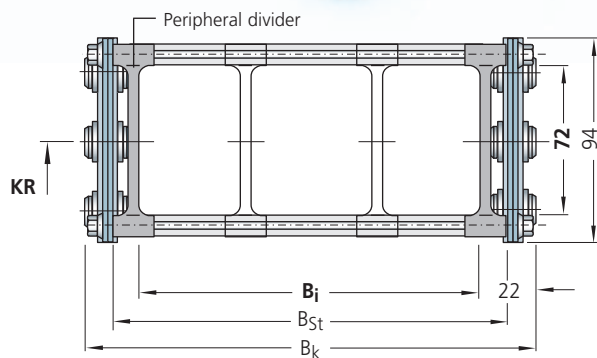

All chain cross sections according to sectional information in the schematic illustration.

The peripheral dividers are an integral part of the stay system and must not be ordered separately.

### Intrinsic chain weight

for two band chains

depending on the chain width.

Weight of the chain bands:  
12 kg/m (excluding stays)

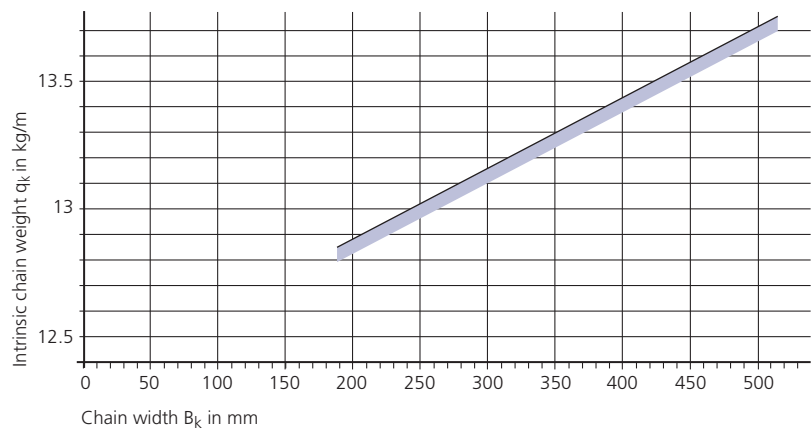

### Divider system TS 0 for stay variant RS 2

The dividers are **movable**.

$s_T$	= 5 mm
$a_T \text{ min}$	= 12.5 mm
$a_x \text{ min}$	= 15 mm

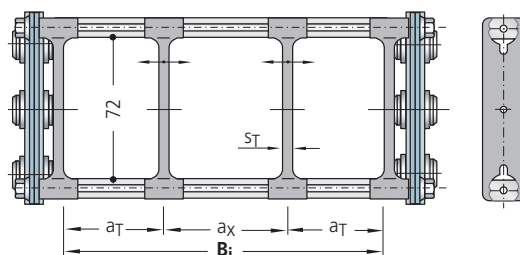

Example for ordering – divider system TS 0

<b>TS 0</b>	/	<b>2</b>
Divider system		Number of dividers $n_T$

# Type S 1250 / SX 1250

## Stay variant RS 1 – with a detachable stay

- frame stay RS made of aluminium – standard design
- for lightweight to medium loads
- **Standard opening options:**
  - Outside:** The cable carrier can be opened quickly and easily simply by rotating the stays through 90°.
  - Inside:** Screwed stays
  - Optional:** Bolted on the outside and opening inwards, please state when ordering.
- **Standard stay arrangement:** on every 2nd chain link. Stays can be fitted on every chain link, please specify when placing your order.

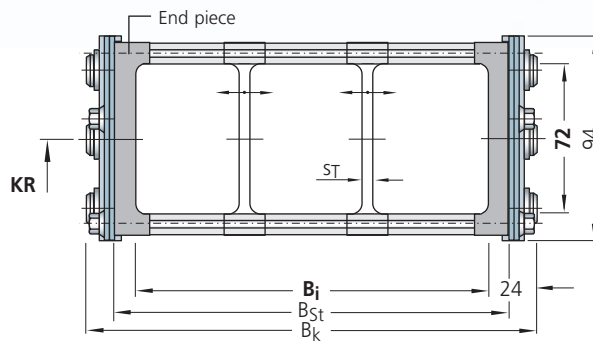
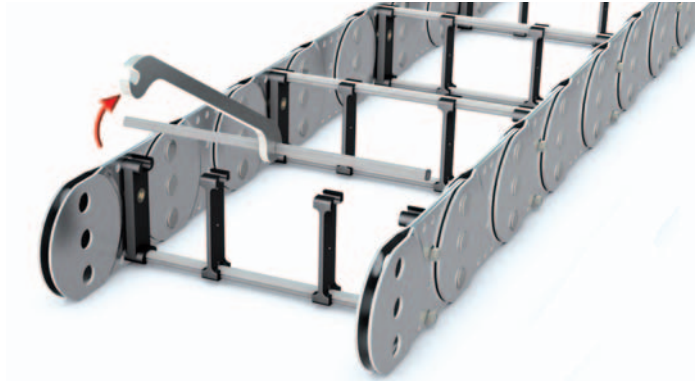

### Chain width:

$$B_k = B_i + 48 \text{ mm}$$

$$B_{k \text{ min}} = 200 \text{ mm}$$

$$B_{k \text{ max}} = 400 \text{ mm}$$

### Stay width:

$$B_{St} = B_i + 24 \text{ mm}$$

$$B_{St} = B_k - 24 \text{ mm}$$

All chain cross sections according to sectional information in the schematic illustration.

The end pieces are an integral part of the stay system and must not be ordered separately.

## Intrinsic chain weight

for two band chains

depending on the chain width.

Weight of the chain bands:  
12 kg/m (excluding stays)

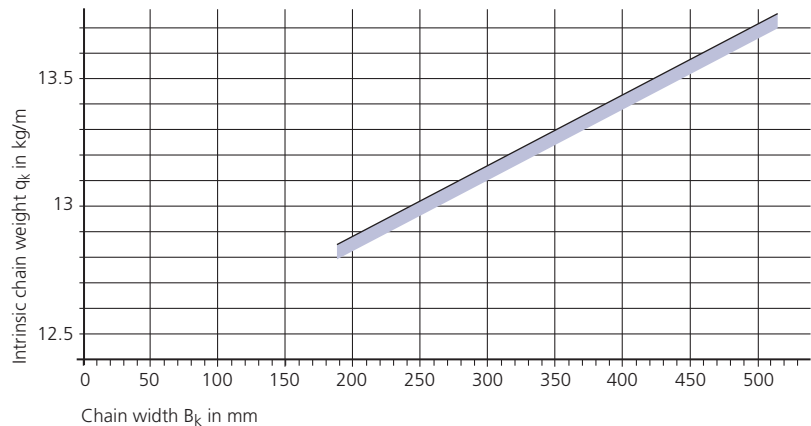

## Divider system TS 0 for stay variant RS 1

The dividers are **movable**.

$s_T$	= 5 mm
$a_T \text{ min}$	= 12.5 mm
$a_x \text{ min}$	= 15 mm

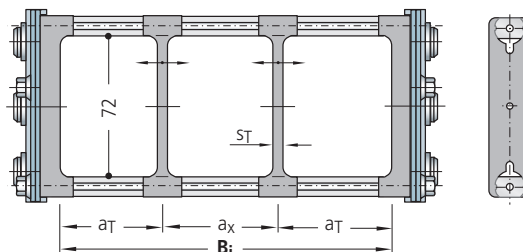

**Example for ordering – divider system TS 0**

<b>TS 0</b>	/	<b>2</b>
Divider system		Number of dividers $n_T$

## Type S 1250 / SX 1250

### Stay variant RV – frame stay, reinforced design

- frame stay RV made of aluminium – reinforced design
- for medium to heavy loads and for large chain width
- **Standard stay arrangement:** on every 2nd chain link. Stays can be fitted on every chain link, please specify when placing your order.
- bolted stays for maximum stability

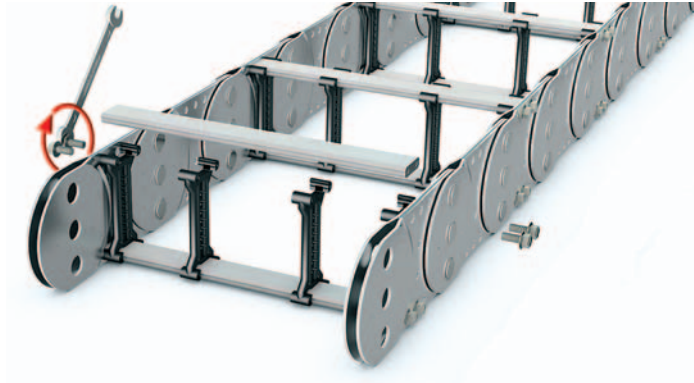

#### Chain width:

$$B_k = B_i + 46 \text{ mm}$$

$$B_{k \text{ min}} = 200 \text{ mm}$$

$$B_{k \text{ max}} = 600 \text{ mm}$$

#### Stay width:

$$B_{St} = B_i + 22 \text{ mm}$$

$$B_{St} = B_k - 24 \text{ mm}$$

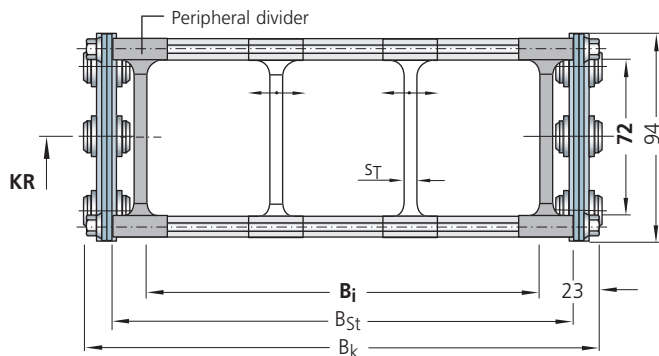

All chain cross sections according to sectional information in the schematic illustration.

The peripheral dividers are an integral part of the stay system and must not be ordered separately.

### Intrinsic chain weight

for two band chains  
depending on the chain width.

Weight of the chain bands:  
12 kg/m (excluding stays)

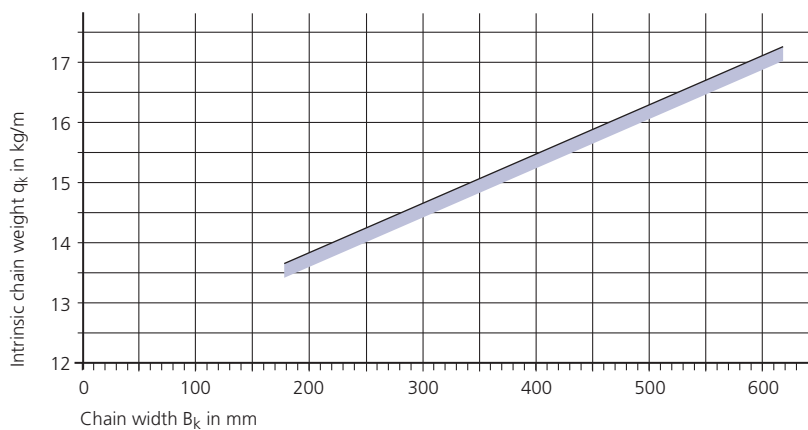

### Divider system TS 0 for stay variant RV

The dividers are **movable**.

$s_T$	= 6 mm
$a_{T \text{ min}}$	= 13 mm
$a_{x \text{ min}}$	= 16 mm

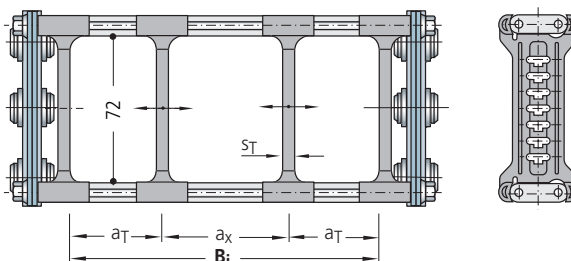

Example for ordering  
– divider system TS 0

TS 0	/	2
Divider system		Number of dividers $n_T$

# Type S 1250 / SX 1250

## Stay variant RV – frame stay, reinforced design

### Divider system TS 1 for stay variant RV with continuous height subdivision

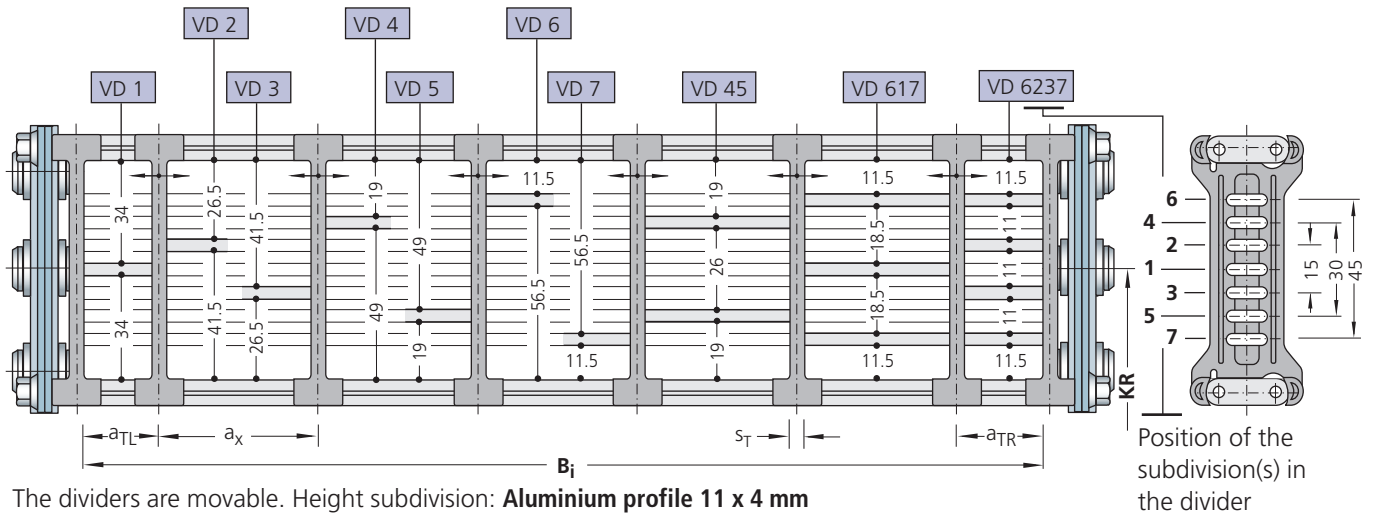

The dividers are movable. Height subdivision: **Aluminium profile 11 x 4 mm**

$s_T$	= 6 mm
$a_{T \min}$	= 13 mm
$a_{x \min}$	= 16 mm
$n_T \min$	= 2

**Example for ordering – divider system TS 1 with continuous height subdivision**

<b>TS 1</b> Divider system	-	<b>VD 1</b> Height subdivision variant	/	<b>6</b> Number of dividers $n_T$
-------------------------------	---	---	---	--------------------------------------

### Divider system TS 2 for stay variant RV with grid subdivision (1 mm grid)

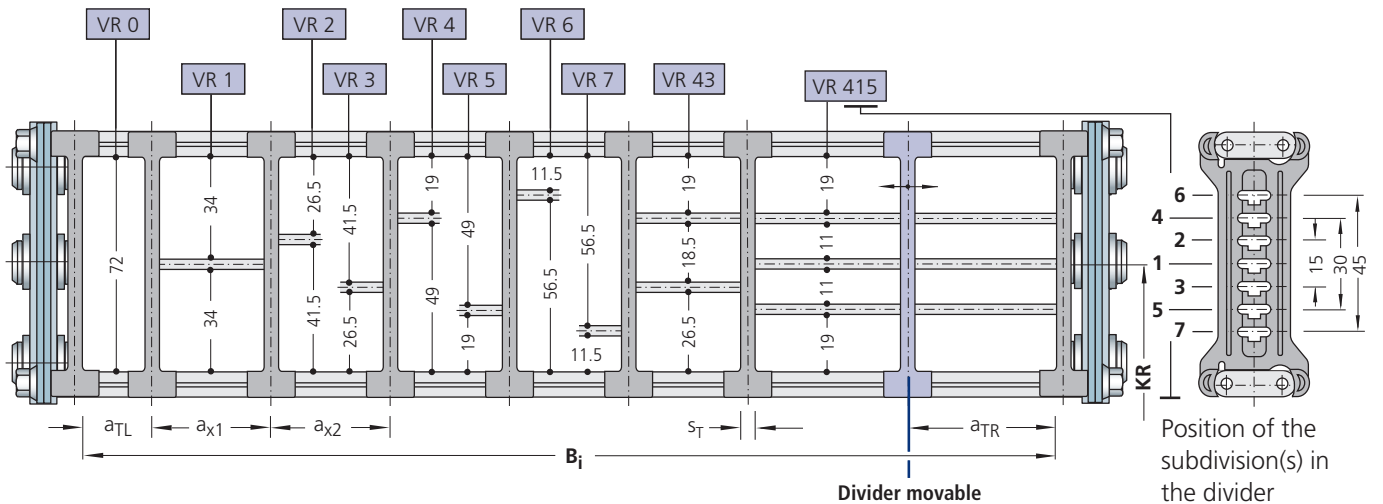

The dividers are fixed by the height subdivision, the complete divider system is movable. Optional movable **dividers ( $s_T = 6$  mm)** are available.

Height subdivision: **Aluminium profile 11 x 4 mm**

$s_T$	= 6 mm
$a_{T \min}$	= 13 mm
$a_{x \min}$	= 20 mm (with height subdivision)
$a_{x \min}$	= 16 mm (for VR 0)
$n_T \min$	= 2

**Example for ordering – divider system TS 2 with grid subdivision**

<b>TS 2</b> Divider system	-	<b>K 1</b> Chamber	-	<b>VR 0</b> Variant of the height subdivision in chamber	/	<b>40</b> Installation interval (mm)
		<b>K 2</b>		<b>VR 1</b>	/	<b>42</b>

Please state the chambers from left to right and the dimensions  $a_T/a_x$  when ordering. Possibly enclose a sketch with dimensions.

## Type S 1250 / SX 1250

### Stay variant RV – frame stay, reinforced design

Divider system TS 3 for stay variant RV:

Section subdivision with partitions made of plastic or aluminium

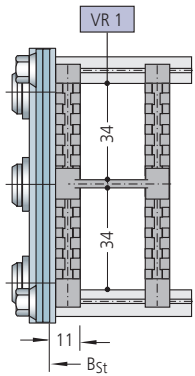
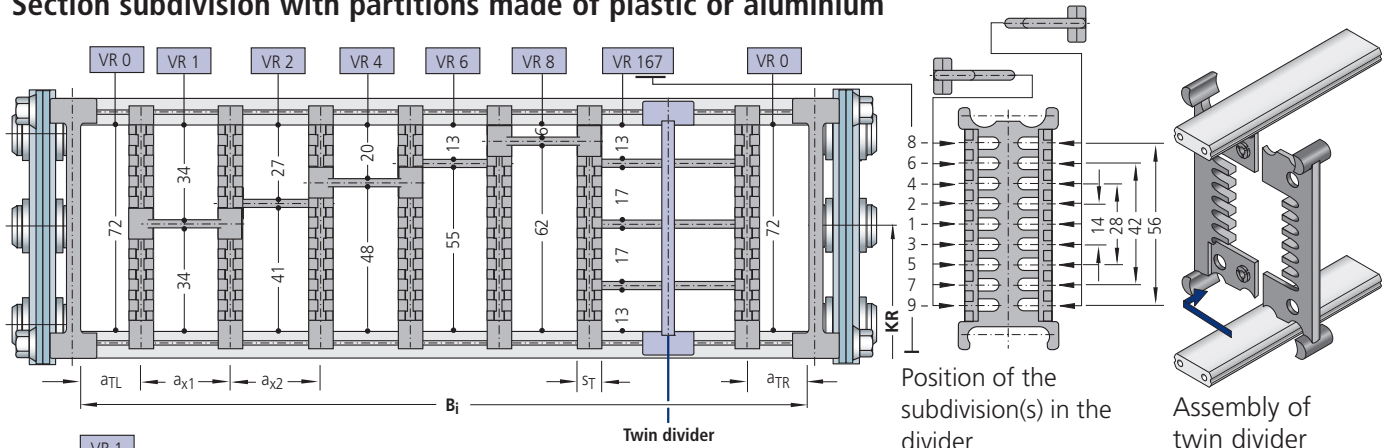

The dividers are fixed by the partitions, the complete divider system is movable. Optional movable **twin dividers** ( $s_T = 4 \text{ mm}$ ) are available. Twin dividers can also be assembled at a later date.

Dimensions without VR 0 chamber at the edge. The outer dividers replace the peripheral dividers.

$s_T$	= 8 mm
$a_T \text{ min}$	= 4 mm
$a_x \text{ min}$	= see partitions dimensions
$n_T \text{ min}$	= 2

#### Example for ordering – divider system TS 3 with partitions made of plastic

TS 3	-	K 1	-	VR 0	/	34
Divider system		Chamber		Variant of the height subdivision in chamber		Installation interval (mm)
		K 2		VR 1	/	38

Please state the chambers from left to right and the dimensions  $a_T/a_x$  when ordering. Possibly enclose a sketch with dimensions.

Please state additional twin dividers when ordering.

### Dimensions of the partitions for TS 3

Partitions made of plastic (Standard)

Dimensions in mm

$a_x$ (Center to center distance, dividers)									
16	18	23	28	32	33	38	43	48	58
64	68	78	80	88	96	112	128	144	160
176	192	208							

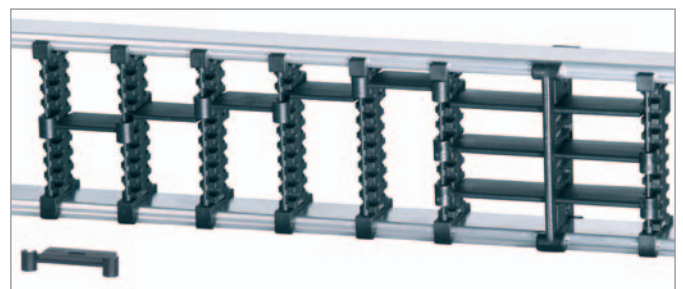
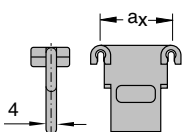

When using **partitions with  $a_x > 112 \text{ mm}$** , there must be an additional central support with a **twin divider**. Twin dividers are suitable for subsequent installation in the partition system.

Alternatively, partitions made of aluminium in 1 mm section widths ( $a_x \text{ min} = 42 \text{ mm}$ ) are also available.



## Type S 1250 / SX 1250

### Stay variant RV – frame stay, reinforced design

Divider system TS 4 for stay variant RV:  
Half dividers and continuous height subdivision

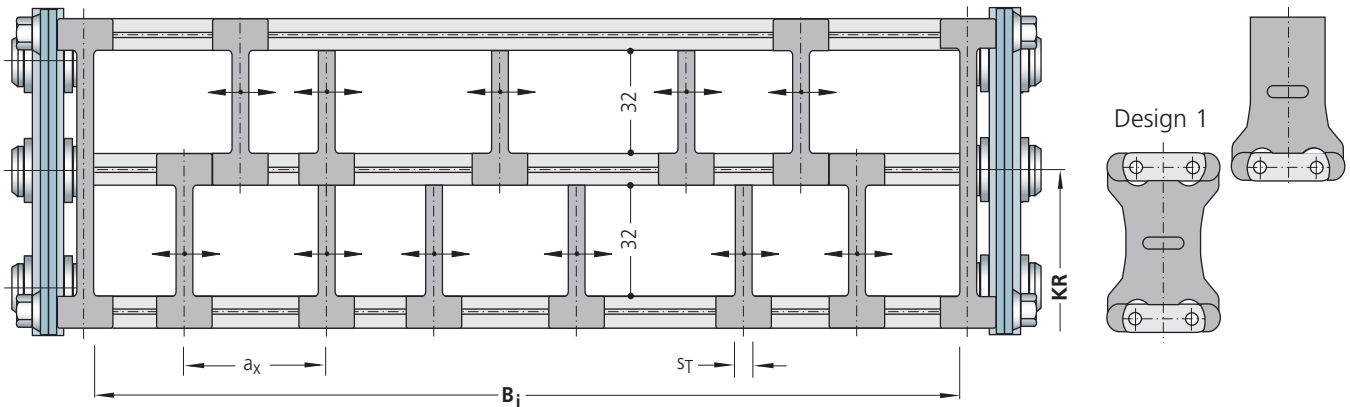

The half dividers are movable. Height subdivision: **Aluminium profile 27 x 8 mm.**  
At least 2 half dividers with wrap-around on both sides (design 1)  
must be installed in the top and bottom chambers in the vicinity of the chain band.

$s_T$	= 4 mm
$a_x \text{ min}$	= 15 mm

#### Ordering – divider system TS 4 with half dividers and continuous height subdivision

Please enclose a sketch with dimensions.  
Please state the dimensions at  $s_T/a_x$ .



## Type S 1250 / SX 1250

### Stay variant RM – frame stay, solid design

- frame stay RM made of aluminium – solid design
- for heavy loads – maximum chain widths possible
- **Standard stay arrangement:** on every 2nd chain link. Stays can be fitted on every chain link, please specify when placing your order.
- bolted stays for maximum stability

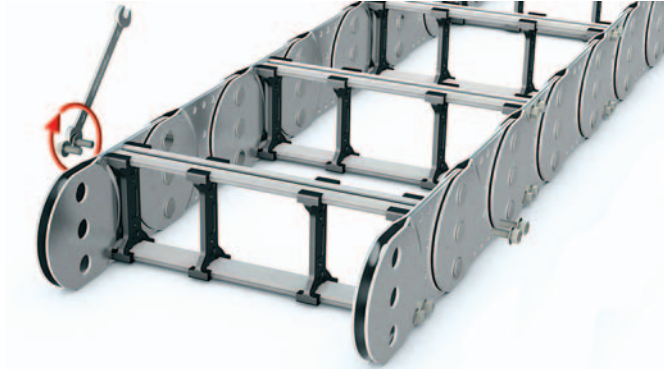

#### Chain width:

$$B_k = B_i + 49 \text{ mm}$$

$$B_{k \text{ min}} = 200 \text{ mm}$$

$$B_{k \text{ max}} = 800 \text{ mm}$$

#### Stay width:

$$B_{St} = B_i + 25 \text{ mm}$$

$$B_{St} = B_k - 24 \text{ mm}$$

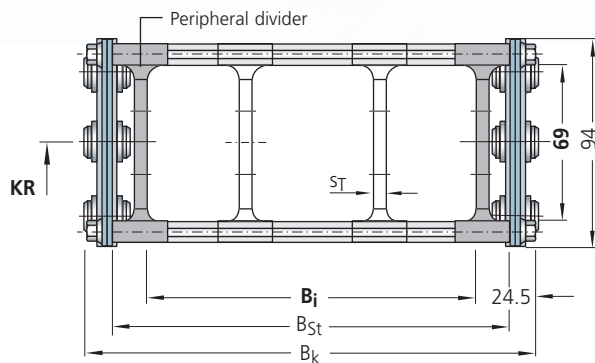

All chain cross sections according to sectional information in the schematic illustration.

The peripheral dividers are an integral part of the stay system and must not be ordered separately.

### Intrinsic chain weight

for two band chains

depending on the chain width.

Weight of the chain bands:  
12 kg/m (excluding stays)

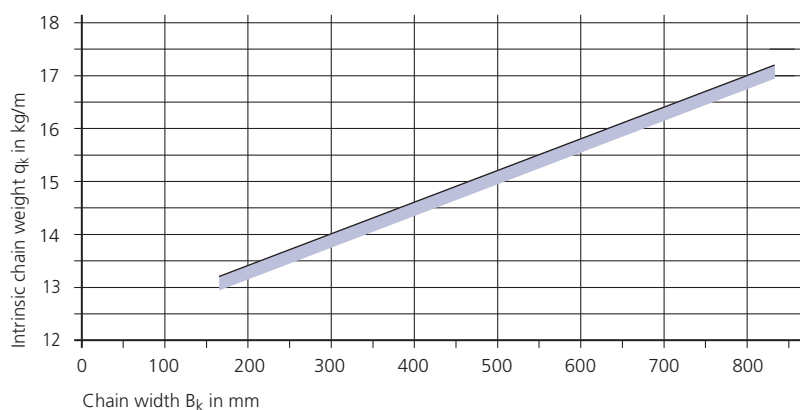

### Divider system TS 0 for stay variant RM

The dividers are **movable**.

$s_T$	= 5 mm
$a_T \text{ min}$	= 17.5 mm
$a_x \text{ min}$	= 20 mm

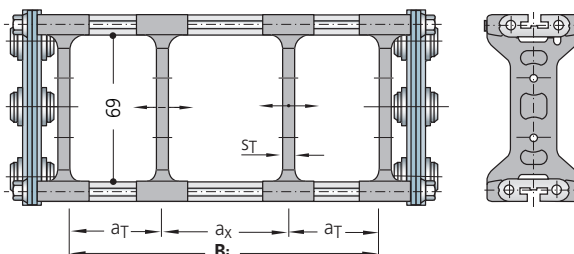

Example for ordering  
– divider system TS 0

TS 0	/	2
Divider system		Number of dividers $n_T$

# Typenreihe S 1250 / SX 1250

## Stay variant RM – frame stay, solid design

### Divider system TS 1 for stay variant RM with continuous height subdivision

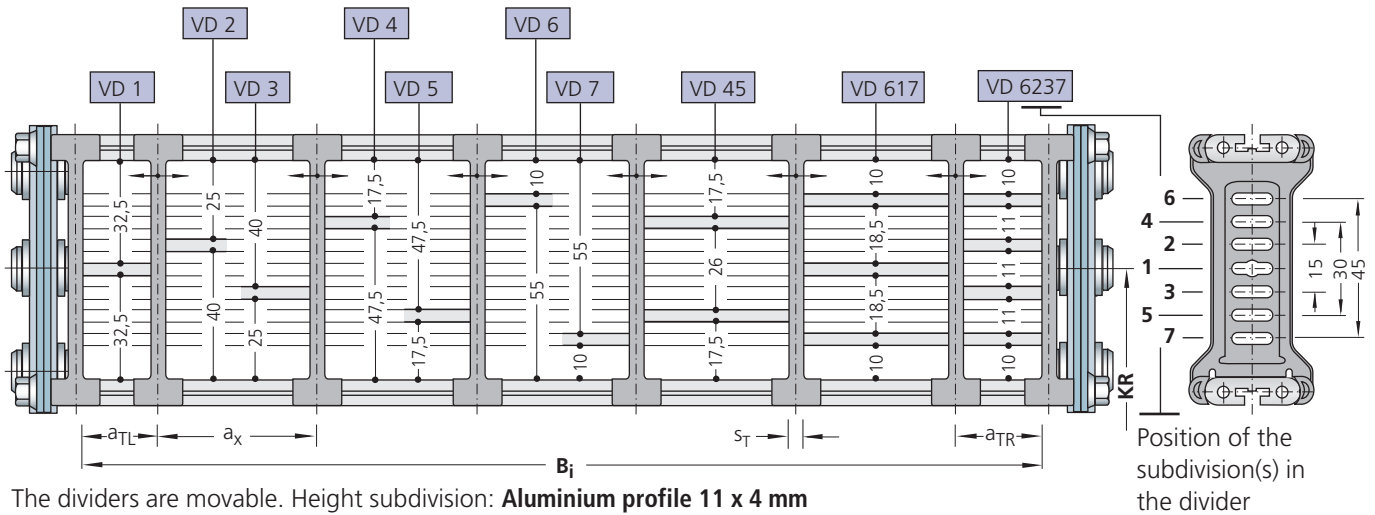

The dividers are movable. Height subdivision: Aluminium profile 11 x 4 mm

$s_T$	= 4 mm
$a_{T \min}$	= 13,5 mm
$a_{x \min}$	= 12 mm
$n_T \min$	= 2

**Example for ordering – divider system TS 1 with continuous height subdivision**

<b>TS 1</b> Divider system	-	<b>VD 1</b> Height subdivision variant	/	<b>6</b> Number of dividers $n_T$
-------------------------------	---	---	---	--------------------------------------

### Divider system TS 2 for stay variant RM with grid subdivision (1 mm grid)

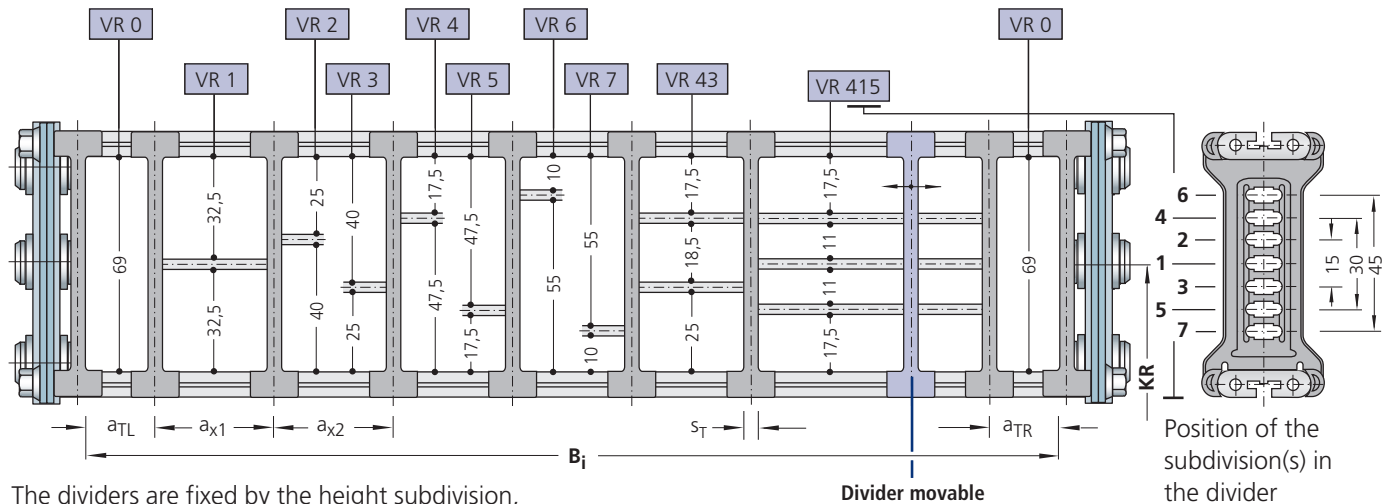

The dividers are fixed by the height subdivision, the complete divider system is movable. Optional movable dividers ( $s_T = 6 \text{ mm}$ ) are available.

Height subdivision: Aluminium profile 11 x 4 mm

$s_T$	= 6 mm
$a_{T \min}$	= 14,5 mm*
$a_{x \min}$	= 20 mm (with height subdivision)
$a_{x \min}$	= 14 mm (for VR 0)
$n_T \min$	= 2

**Example for ordering – divider system TS 2 with grid subdivision**

<b>TS 2</b> Divider system	-	<b>K 1</b> Chamber	-	<b>VR 0</b> Variant of the height subdivision in chamber	/	<b>40</b> Installation interval (mm)
		<b>K 2</b>		<b>VR 1</b>	/	<b>42</b>

Please state the chambers from left to right and the dimensions  $a_T/a_x$  when ordering. Possibly enclose a sketch with dimensions.

\* If the height subdivision extends to the edge separator, the  $a_{T \min}$  dimension changes to 11 mm.

## Type S 1250 / SX 1250

### Stay variant RM – frame stay, solid design

#### Divider system TS 5 for stay variant RM

Hole stay inserts made of plastic – split design

##### Chain width:

$$B_K = \sum n_p \cdot B_p + 25 \text{ mm}$$

$n_p$  = number of hole stay inserts  
 $B_p$  = width of the hole stay inserts

##### Stay width:

$$B_{ST} = \sum n_p \cdot B_p + 1 \text{ mm}$$

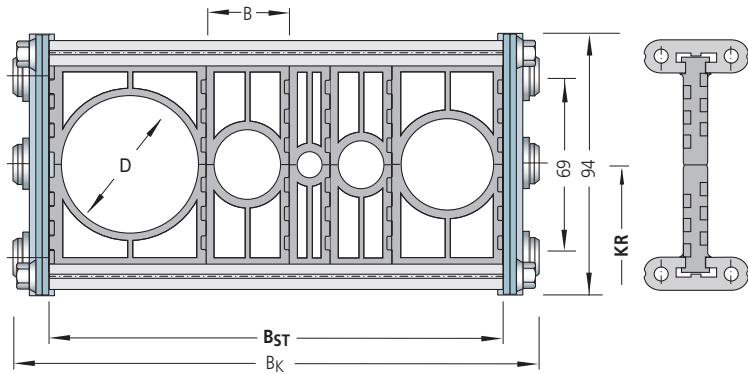

Hole diameter D	Width B
10	15
15	20
20	25
25	30
30	35
40	45
50	55

Dimensions in mm

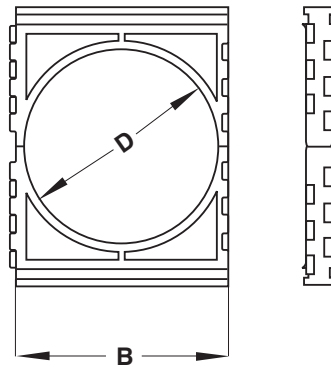

The hole stay inserts can be combined in any way.

#### Example for ordering – divider system TS 5

<b>TS 5</b>	/	<b>50</b>	-	<b>30</b>	-	<b>25</b>	-	<b>40</b>
Divider system		Hole diameter D <sub>1</sub>		Hole diameter D <sub>2</sub>		Hole diameter D <sub>3</sub>		Hole diameter D <sub>4</sub>

Please state the hole diameters and positions from left to right when ordering. Possibly enclose a sketch with dimensions.

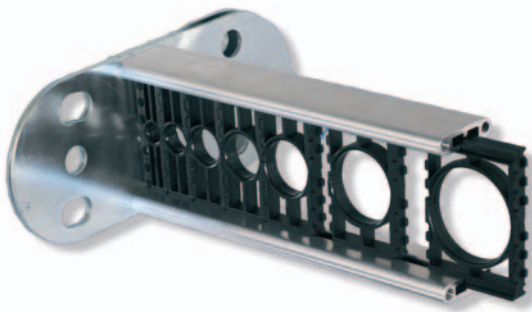

# Type S 1250 / SX 1250

## Stay variant RMA – mounting frame stay

- for very large cable diameters such as with air hoses.
- cables with diameters greater than the clearance height of the chain links can be routed
- installed on the inside or outside in the bend radius according to preference
- **Standard stay arrangement:**  
on every 2nd chain link.  
Stays can be fitted on every chain link, please specify when placing your order.
- bolted stays for maximum stability

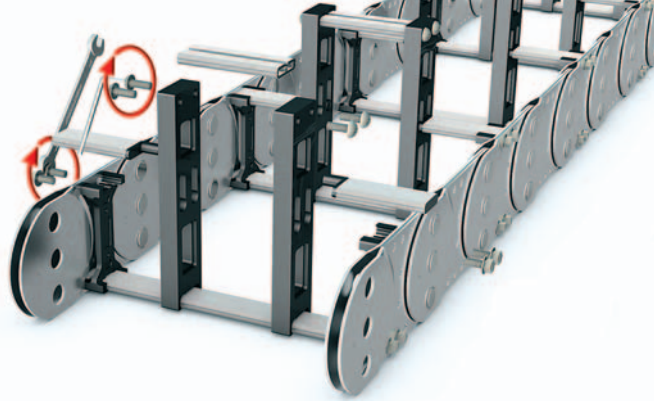

### Chain width:

$$B_k = B_i + 44 \text{ mm}$$

$$B_{k \text{ min}} = 200 \text{ mm}$$

$$B_{k \text{ max}} = 600 \text{ mm}$$

$$B_{i1 \text{ min}} = 24 \text{ mm}$$

$$B_{i2 \text{ min}} = 128 \text{ mm}$$

$$B_{i3 \text{ min}} = 24 \text{ mm}$$

$$S_{TA} = 15 \text{ mm}$$

### Stay width:

$$B_{St} = B_i + 20 \text{ mm}$$

$$B_{St} = B_k - 24 \text{ mm}$$

### Available passage heights:

$$H_i = 130, 160, 200 \text{ mm}$$

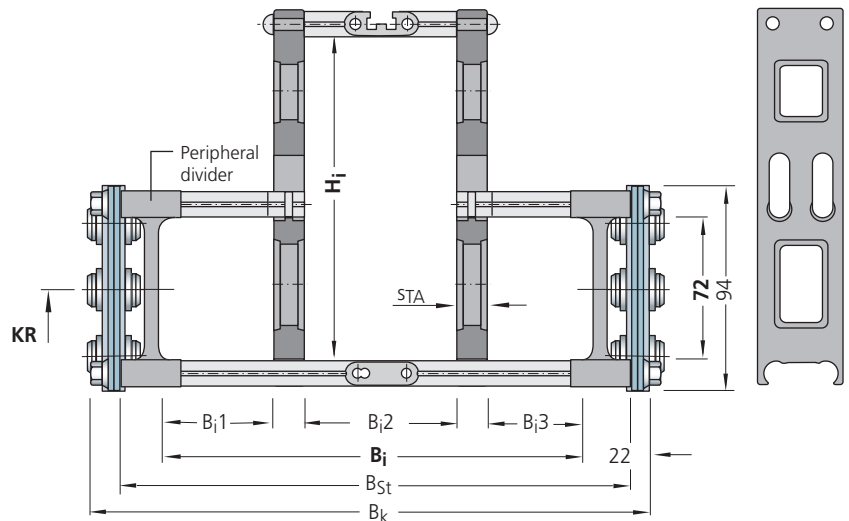

**All chain cross sections according to sectional information in the schematic illustration.**

The peripheral dividers are an integral part of the stay system and must not be ordered separately.

**On account of the design parameters to be observed, we ask you to contact our technical consultants.**

**Assembly on the inside –**  
observe minimum bend radius (half-stayed arrangement):

$$H_i = 130 \text{ mm: } KR_{\text{min}} = 200 \text{ mm}$$

$$H_i = 160 \text{ mm: } KR_{\text{min}} = 260 \text{ mm}$$

$$H_i = 200 \text{ mm: } KR_{\text{min}} = 300 \text{ mm}$$

Minimum bend radius full-stayed –  
please ask us about it.

The cable carrier must be supported  
on the chain band and not on the stays.

## Intrinsic chain weight

**for two band chains**

depending on the chain width.

Weight of the chain bands:  
12 kg/m (excluding stays)

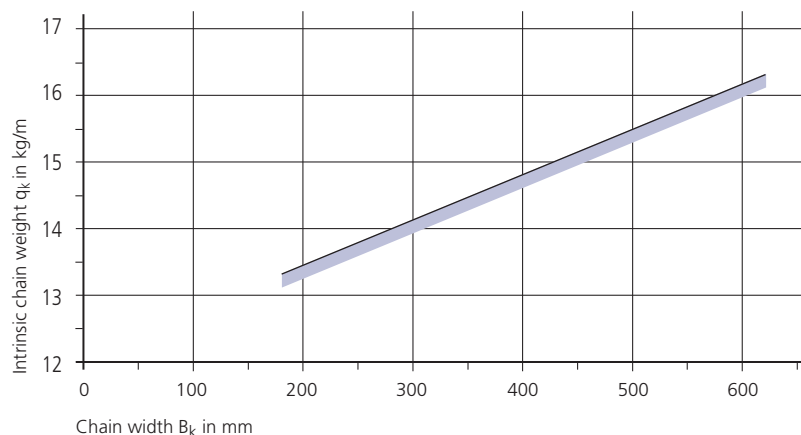

## Type S 1250 / SX 1250

### Stay variant RMR – frame stay with plastic roller system

- gentle cable support due to rotatable plastic rollers
- ideal when using media hoses with "soft" sheaths
- stay profile made of aluminium – rollers made of plastic
- plastic dividers in roller version
- Standard stay arrangement:**  
on every 2nd chain link.  
Stays can be fitted on every chain link, please specify when placing your order.
- bolted stays for maximum stability

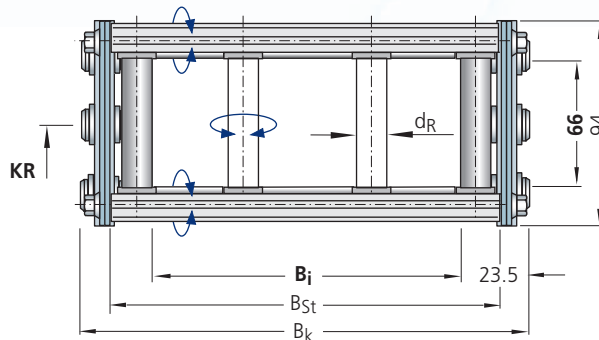
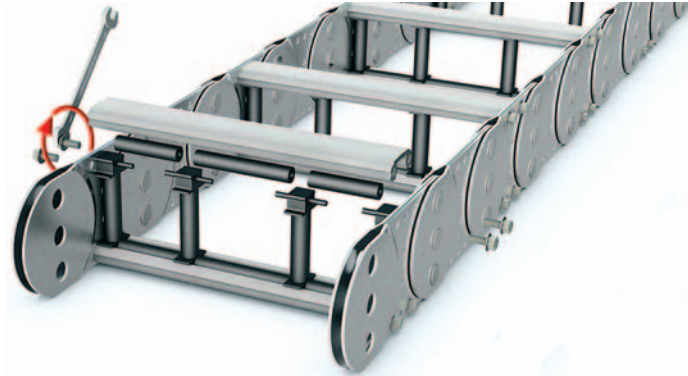

#### Chain width:

$$B_k = B_i + 47 \text{ mm}$$

$$B_k \text{ min} = 200 \text{ mm}$$

$$B_k \text{ max} = 800 \text{ mm}$$

#### Stay width:

$$B_{St} = B_i + 24 \text{ mm}$$

$$B_{St} = B_k - 23 \text{ mm}$$

### Intrinsic chain weight

for two band chains  
depending on the chain width.

Weight of the chain bands:  
12 kg/m (excluding stays)

All chain cross sections according to the section information in the schematic illustration.

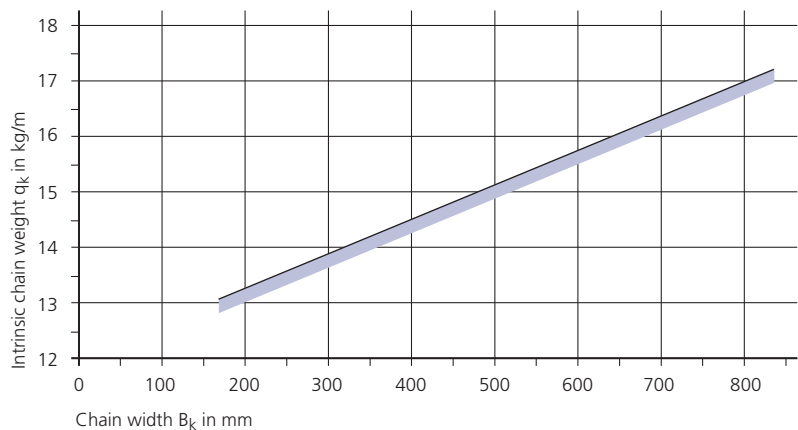

### Divider system TS 0 for stay variant RMR

The standard dividers are **fixed**.  
Moveable dividers ( $s_T = 4 \text{ mm}$ ) can be used as an option. Please state when ordering.

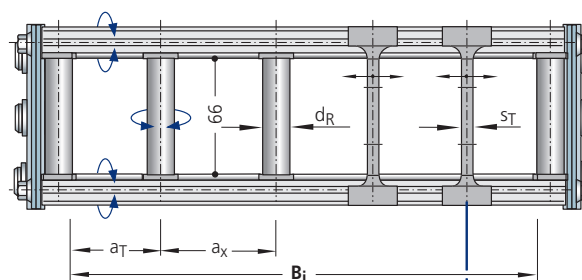

**Example for ordering – divider system TS 0**

<b>TS 0</b>	/	<b>2</b>
Divider system		Number of dividers $n_T$

Please state the dimensions  $a_T/a_x$  when ordering. Possibly enclose a sketch with dimensions.

$d_R$	= 10 mm
$a_T \text{ min}$	= 11.5 mm
$a_x \text{ min}$	= 37 mm

The dividers are movable.

# Type S 1250 / SX 1250

## Stay variant RR – frame stay, tube design

- gentle cable support due to rotating metal tubes
- ideal when using media hoses with "soft" sheaths
- possible materials of the axles, tubes and dividers:
  - axles and tubes, zinc-plated steel with plastic dividers (**Standard**)
  - axles, tubes and dividers made of zinc-plated steel
  - axles, tubes and dividers made of stainless steel ER 1, ER 1S
- **Standard stay arrangement:** on every 2nd chain link. Stays can be fitted on every chain link, please specify when placing your order.
- bolted stays for maximum stability

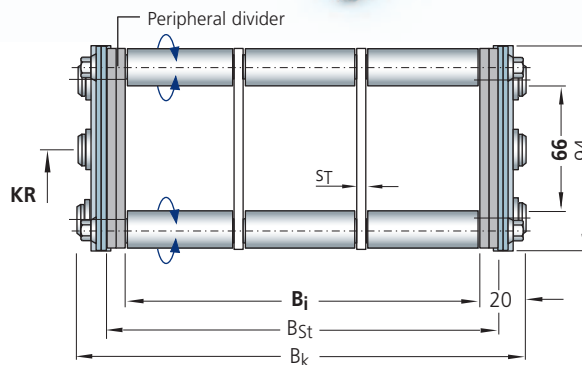
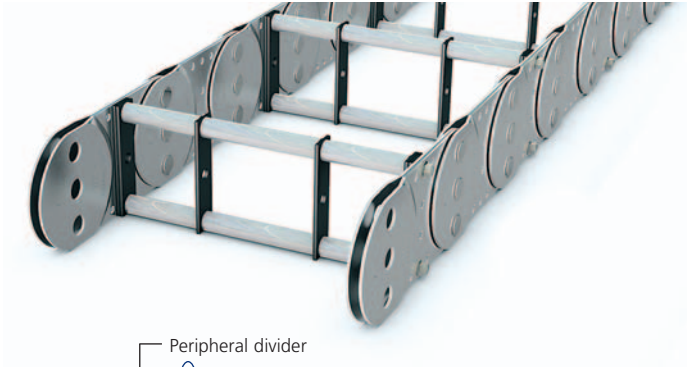

All chain cross sections according to sectional information in the schematic illustration.

The peripheral dividers are an integral part of the stay system and must not be ordered separately.

### Chain width:

$$B_k = B_i + 40 \text{ mm}$$

$$B_k \text{ min} = 200 \text{ mm}$$

$$B_k \text{ max} = 600 \text{ mm}$$

### Stay width:

$$B_{St} = B_i + 16 \text{ mm}$$

$$B_{St} = B_k - 24 \text{ mm}$$

## Intrinsic chain weight

for two band chains

depending on the chain width.

Weight of the chain bands:

12 kg/m (excluding stays)

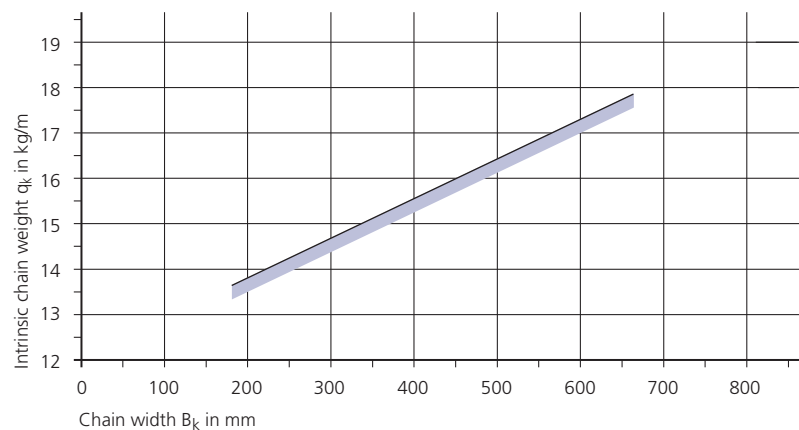

## Divider systems TS 0 and TS 1 for stay variant RR

The dividers are **fixed**.

**TS 0:** without height subdivision

**TS 1:** with continuous centric height subdivision

$s_T$	= 4 mm
$a_{T \text{ min}}$	= 30 mm
$a_{x \text{ min}}$	= 30 mm

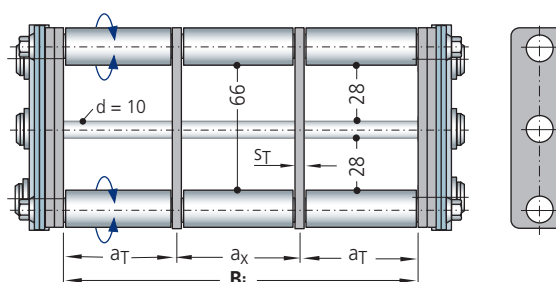

**Example for ordering – divider system**

<b>TS 0</b>	/	<b>2</b>
Divider system		Number of dividers $n_T$

Please state the dimensions  $a_T/a_x$  when ordering. Possibly enclose a sketch with dimensions.

## Type S 1250 / SX 1250

### Stay variant LG – hole stay made of aluminium, split design

- optimum cable guidance in the neutral bending line is possible
- drilling pattern individually adapted to the application
- high stability due to solid construction
- split design as standard for easy laying of the cables
- **Standard stay arrangement:**  
on every 2nd chain link.  
Stays can be fitted on every chain link, please specify when placing your order.
- bolted stays for maximum stability  
– also available not split

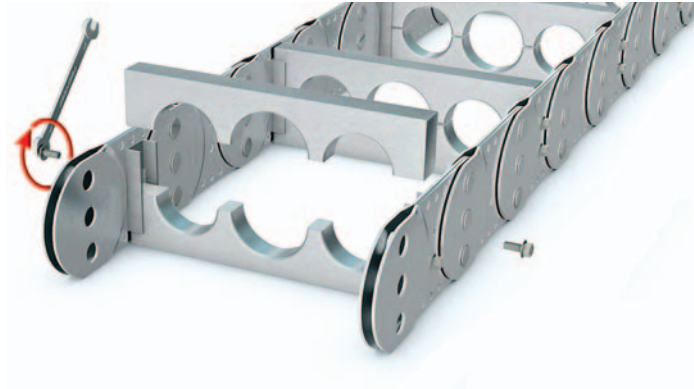

#### Chain width:

$$B_k = \sum D + \sum c + 48 \text{ mm}$$

$$B_k \text{ min} = 130 \text{ mm}$$

$$B_k \text{ max} = 800 \text{ mm}$$

#### Stay width:

$$B_{St} = \sum D + \sum c + 22 \text{ mm}$$

$$B_i = B_{St} - 2 a_0$$

$$B_{St} = B_k - 26 \text{ mm}$$

$$D_{\text{max}} = 74 \text{ mm}$$

$$c_{\text{min}} = 4 \text{ mm}$$

$$a_{0 \text{ min}} = 11 \text{ mm}$$

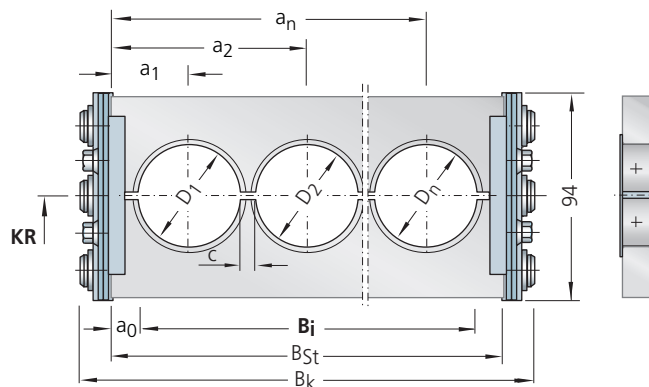

All chain cross sections according to sectional information in the schematic illustration.

### Intrinsic chain weight

#### for two band chains

depending on the chain width.

Hole area of the hole stay is approx. 50 %

Weight of the chain bands:  
12 kg/m (excluding stays)

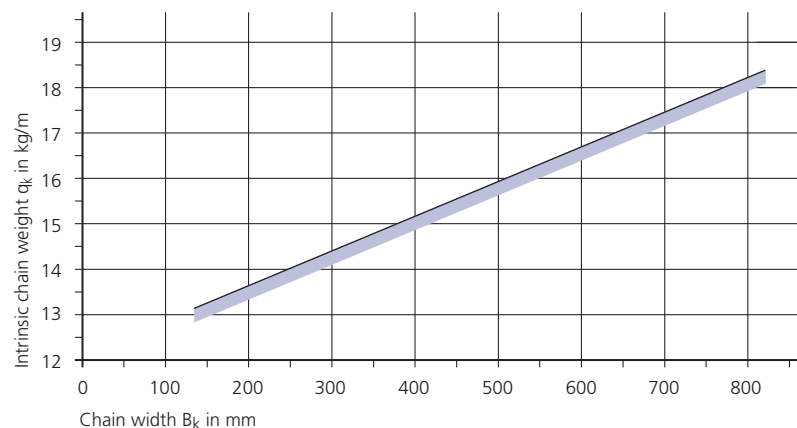

# Type S 1250 / SX 1250

## Stay variant RMD – covered cable carrier, STEEL-TUBE

- **aluminium cover system** for protecting the cables and hoses
- for applications where chips or severe contamination occur
- bolted aluminium cover for maximum stability



Steel band covers are also available as light-weight, economically priced alternatives to covering with the aluminium cover system, see page 172.



### Chain width:

$$B_k = B_i + 49 \text{ mm}$$

$$B_{k \text{ min}} = 150 \text{ mm}$$

$$B_{k \text{ max}} = 800 \text{ mm}$$

### Stay width:

$$B_{St} = B_i + 25 \text{ mm}$$

$$B_{St} = B_k - 24 \text{ mm}$$

### Minimum bend radius

$$KR_{\text{min}} = 200 \text{ mm}$$

### Intrinsic chain weight

for two band chains  
depending on the chain width.

Weight of the chain bands:  
12 kg/m (excluding stays)

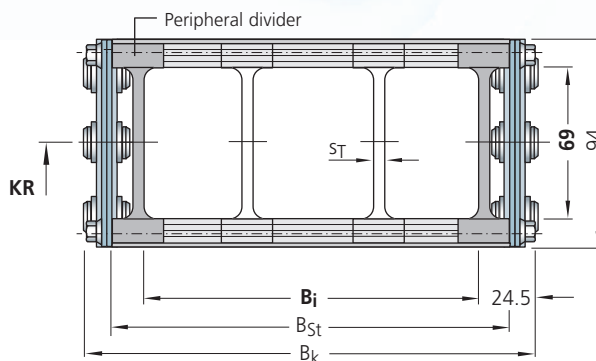

All chain cross sections according to sectional information in the schematic illustration.

The peripheral dividers are an integral part of the stay system and must not be ordered separately.

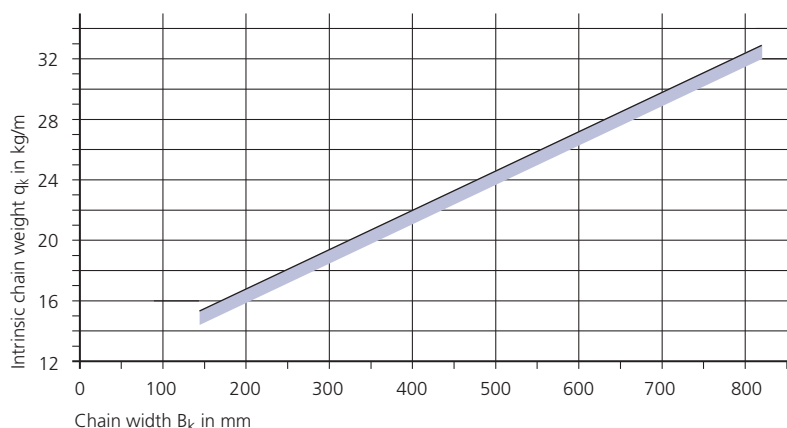

### Divider system TS 0 for stay variant RMD

The dividers are **movable**.

$s_T$	= 5 mm
$a_{T \text{ min}}$	= 17.5 mm
$a_x \text{ min}$	= 20 mm

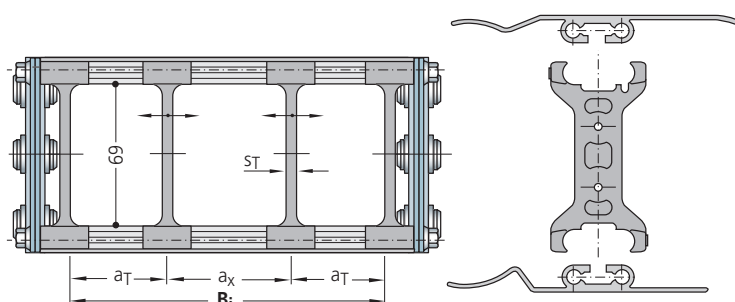

Example for ordering  
– divider system TS 0

<b>TS 0</b>	/	<b>2</b>
Divider system		Number of dividers $n_T$



## Typenreihe S 1250 / SX 1250

### Stay variant RMD – covered cable carrier, STEEL-TUBE

#### Divider system TS 1 for stay variant RMD with continuous height subdivision

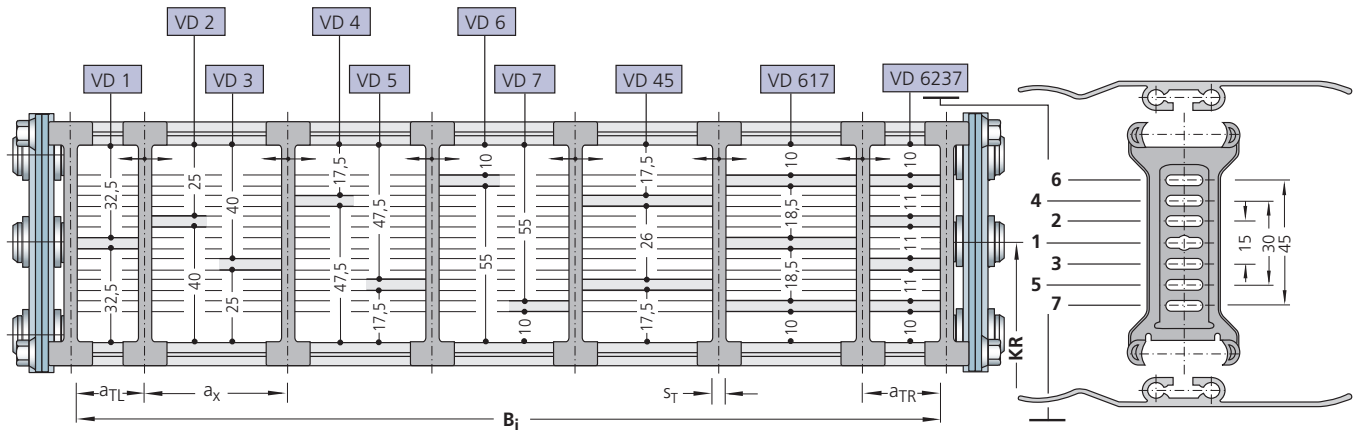

The dividers are movable. Height subdivision: **Aluminium profile 11 x 4 mm**

Position of the subdivision(s) in the divider

$s_T$	= 4 mm
$a_{T \min}$	= 13,5 mm
$a_{x \min}$	= 12 mm
$n_T \min$	= 2

**Example for ordering – divider system TS 1 with continuous height subdivision**

<b>TS 1</b>	-	<b>VD 1</b>	/	<b>6</b>
Divider system		Height subdivision variant		Number of dividers $n_T$

#### Divider system TS 2 for stay variant RMD with grid subdivision (1 mm grid)

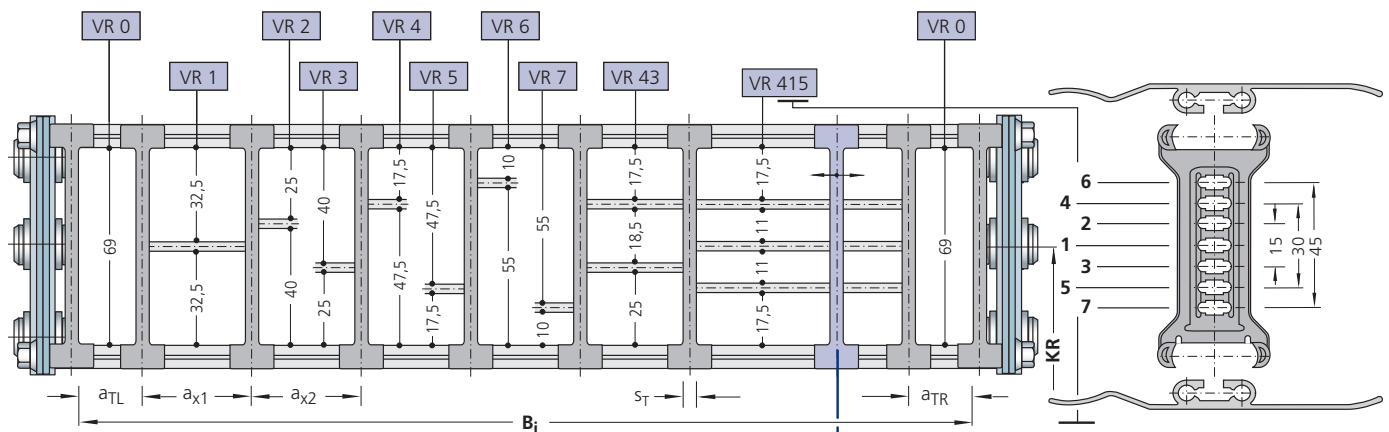

The dividers are fixed by the height subdivision, the complete divider system is movable. Optional movable dividers ( $s_T = 6 \text{ mm}$ ) are available.

Divider movable

Position of the subdivision(s) in the divider

Height subdivision: **Aluminium profile 11 x 4 mm**

$s_T$	= 6 mm
$a_{T \min}$	= 14,5 mm*
$a_{x \min}$	= 20 mm (with height subdivision)
$a_{x \min}$	= 14 mm (for VR 0)
$n_T \min$	= 2

**Example for ordering – divider system TS 2 with grid subdivision**

<b>TS 2</b>	-	<b>K 1</b>	-	<b>VR 0</b>	/	<b>40</b>
Divider system		Chamber		Variant of the height subdivision in chamber		Installation interval (mm)
		<b>K 2</b>	-	<b>VR 1</b>	/	<b>42</b>

Please state the chambers from left to right and the dimensions  $a_T/a_x$  when ordering. Possibly enclose a sketch with dimensions.

\* If the height subdivision extends to the edge separator, the  $a_{T \min}$  dimension changes to 11 mm.

# Type S 1250 / SX 1250

## Fixed point connection

### Connection variant FA

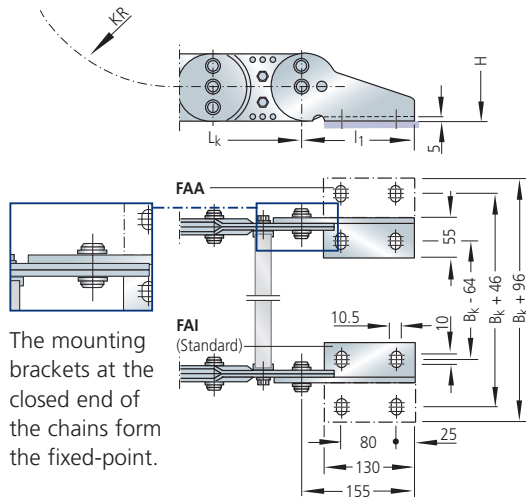

### Connection variant FI

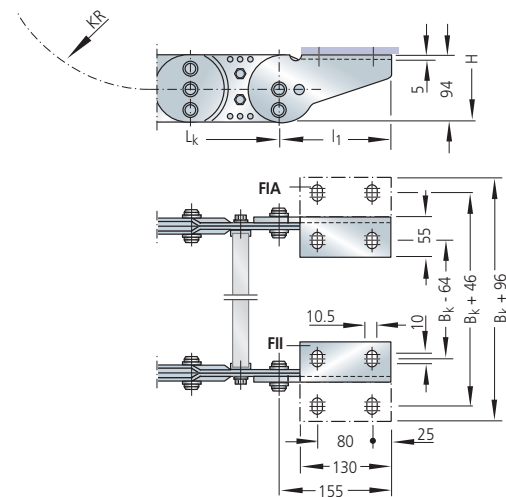

### Connection variant FH

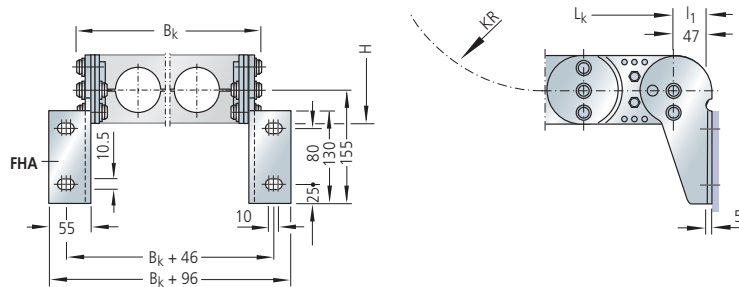

### Connection variant FK

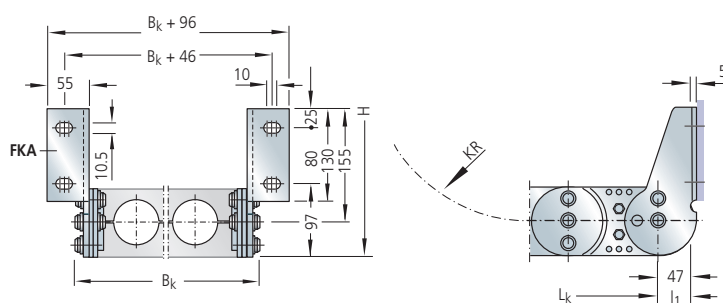

Different connection variants for fixed point and driver are possible according to the drawing information and are realized by different assembly of the connecting pieces.

The connection variants can also be changed at a later date if required.

Please state the desired connection variant according to the ordering key (see page 120).

### Type S 1250 / SX 1250

#### Driver connection

##### Connection variant MA

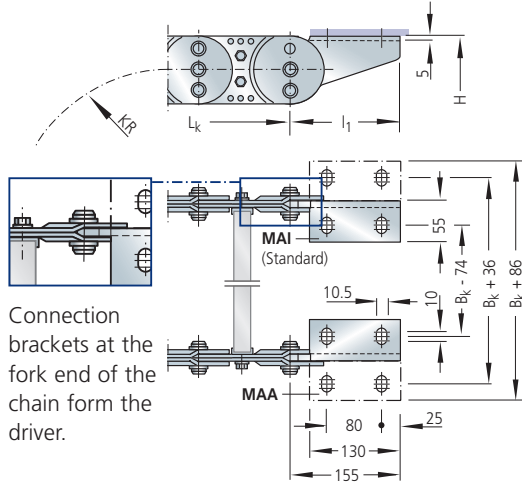

##### Connection variant MI

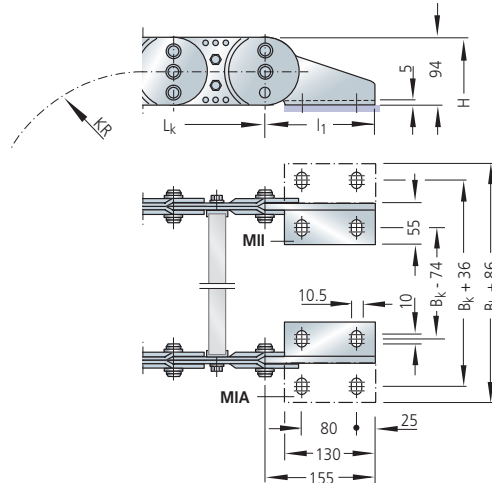

##### Connection variant MH

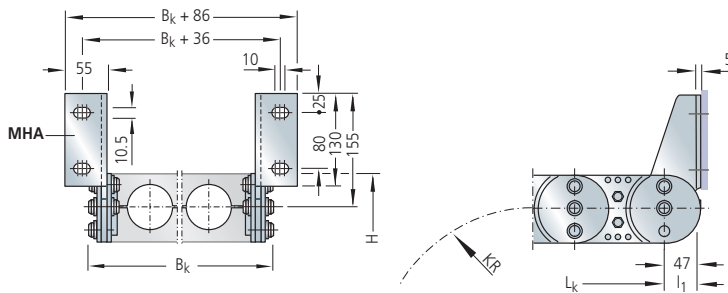

##### Connection variant MK

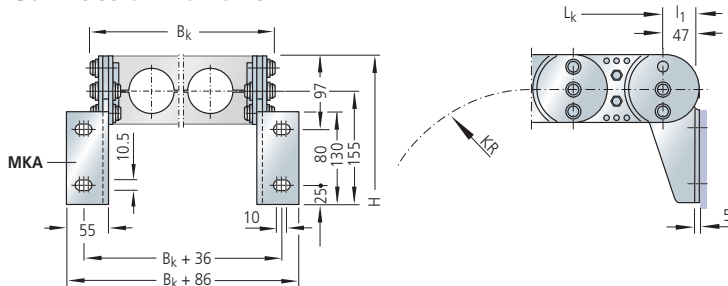

# Type S 1250 / SX 1250

## Ordering – cable carrier

Cable Carrier					
<b>S 1250</b>	<b>352</b>	<b>RV</b>	<b>260</b>	<b>St</b>	<b>4750</b>
Type	Stay width B <sub>St</sub> in mm	Stay variant	Bend radius KR in mm	Chain band material	Chain length L <sub>k</sub> in mm (with- out connection)

### Chain band materials:

- St = zinc-plated steel
- ER 1 = stainless steel
- ER 1S = sea water resistant stainless steel
- ER 2 = high-strength stainless steel

More information:  
See material overview on page 54.

## Ordering – divider system

Divider system	
<b>TS 0</b>	<b>4</b>
Divider system	Number of dividers n <sub>T</sub>

See also the sample order for the respective divider system.

## Ordering – connection

Connection					
<b>F</b>	<b>A</b>	<b>A</b>	<b>M</b>	<b>A</b>	<b>I</b>
Fixed point	Connection type	Connection surface	Driver	Connection type	Connection surface

If no order designation for the connection is stated, we supply the connection variant **FAI/MAI (Standard)**.

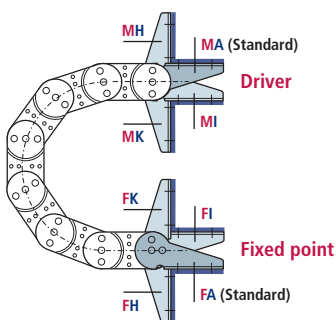

- F** – Fixed point
- M** – Driver
- Connection type**
- A** – Bolts facing outward (Standard)
- I** – Bolts facing inward
- H** – Threaded joint, rotated by 90° to the outside
- K** – Threaded joint, rotated by 90° to the inside

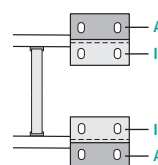

- Connection surface**
- I** – Connector surface inside (< B<sub>k</sub>)
- A** – Connector surface outside (> B<sub>k</sub>)

The connecting surfaces on the driver and fixed point can be mounted on the outside or inside according to preference.

The connection type can easily be altered at a later date.

Guide channels  
➤ from page 166

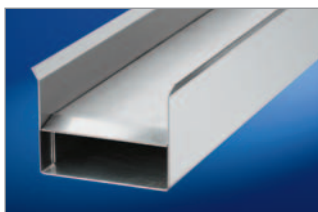

Strain relief devices  
➤ from page 173



Cables for cable carrier systems  
➤ in our TRAXLINE Cables for Motion catalogue.





## Type S 1800

Steel chain bands

## Type SX 1800

Stainless steel chain bands

### Materials

Chain bands and end connectors:

**S 1800:** Steel, zinc-plated

**SX 1800:** grade rust and acid resistant steel

Standard stay material: aluminium alloy\*

Dividers and end pieces: plastic\*\*

→ see material properties, page 54

**STEEL**  
ZINC-PLATED  
**STAINLESS**  
STEEL  
RUST-FREE

2D/3D-Data  
[kabelschlepp.de/cad-gb](http://kabelschlepp.de/cad-gb)

### Chain width

customer-specific

available in 1 mm width sections



### Chain pitch

180 mm

### Bend radii

various **standard bend radii**

from 265 – 1405 mm; intermediate radii upon request

\* See description for the respective stay variant for details.

\*\* Stay variant RR: Dividers of steel.

Also available with straight link plates:

Type S/SX 1852 – please contact us!

### Stay variant RM



Clearance height  $h_i = 108 \text{ mm}$   
➤ from page 123

### Stay variant RR



Clearance height  $h_i = 104 \text{ mm}$   
➤ from page 125

### Stay variant LG



max. hole  $\varnothing = 110 \text{ mm}$   
➤ from page 126

### Stay variant RMD



Clearance height  $h_i = 104 \text{ mm}$   
➤ from page 127

# Type S 1800 / SX 1800

## Rolling schematic illustration unsupported arrangement

- Chain pitch  $t = 180 \text{ mm}$
- Height  $h_G = 140 \text{ mm}$
- Connection height  $H = 2 \text{ KR} + 210 \text{ mm}$  (unsupported)
- Connection length  $l_1 = 210/70 \text{ mm}$  (see connection dimensions)

A flat and level surface is required for the cable carrier to extend and retract reliably.  
Under certain conditions, a support tray needs to be installed (see page 169).

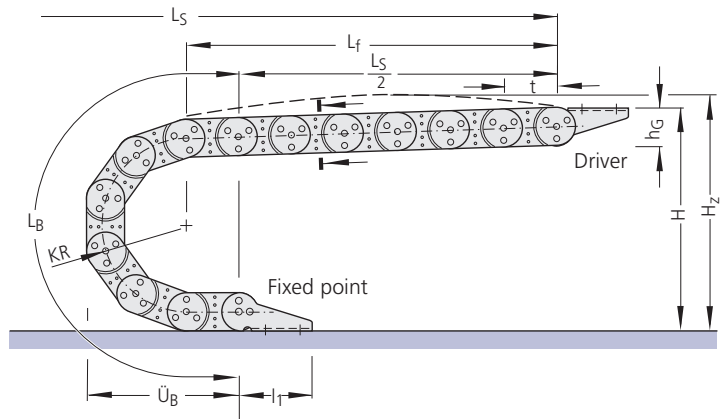

### Variable sizes

depending on the bend radius

Bend radius	265	320	375	435	490	605	720	890	1175	1405
Bend length $L_B$	1552	1725	1898	2087	2259	2620	2982	3516	4411	5164
Bend overhang $\ddot{U}_B$	695	750	805	865	920	1035	1150	1320	1605	1835
Height $H$ (unsupported)	740	850	960	1080	1190	1420	1650	1990	2560	3020

Dimensions in mm

Chain length:
$L_k \approx \frac{L_s}{2} + L_B$

rounded to pitch 180 mm

Installation height*:
$H_z = H + z$

Pre-tension  $z \approx 10 \text{ mm/m}$  chain length  
\* required clear height

## Load diagramm

**Unsupported length  $L_f$  and travel length  $L_s$  without support** depending on the additional load (see design guidelines).

Load diagram for an intrinsic chain weight  $q_k$  of 26 kg/m.

If the intrinsic chain weight  $q_k$  of 26 kg/m is exceeded, the permissible additional load is reduced by the difference.

For circular operations, combinations of KR/RKR are possible. Please contact us for details.

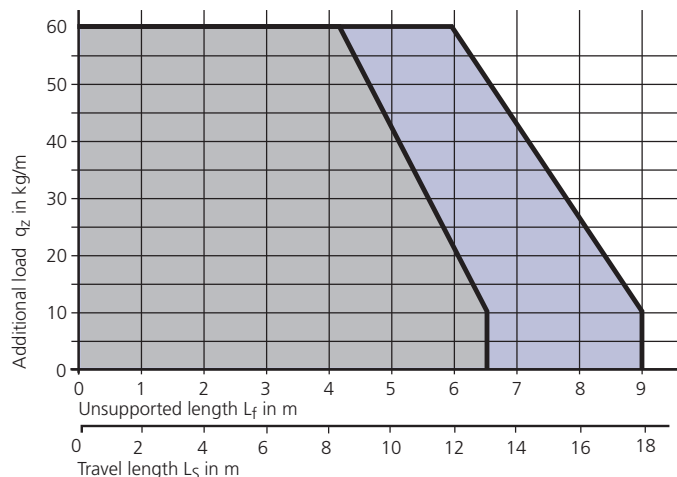

- S 1800 material zinc-plated steel
- SX 1800 material ER 2
- SX 1800 material ER 1 / ER 15

## Type S 1800 / SX 1800

### Stay variant RM – frame stay, solid design

- frame stay RM made of aluminium – solid design
- for heavy loads – maximum chain widths possible
- **Standard stay arrangement:** on every 2nd chain link. Stays can be fitted on every chain link, please specify when placing your order.
- bolted stays for maximum stability

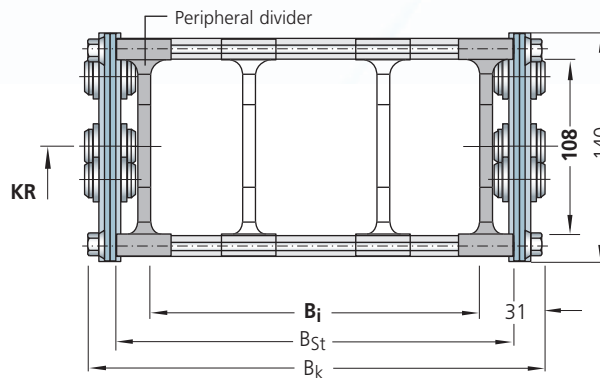
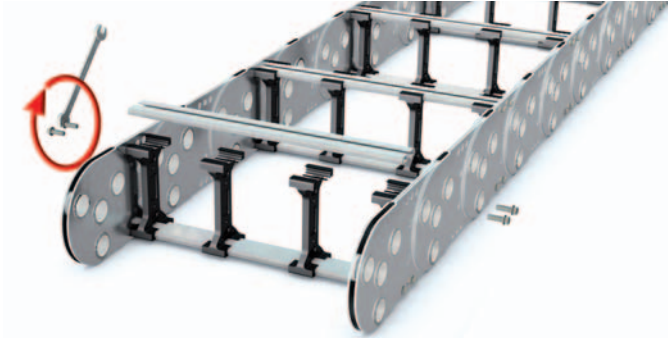

#### Chain width:

$$B_k = B_i + 62 \text{ mm}$$

$$B_{k \text{ min}} = 250 \text{ mm}$$

$$B_{k \text{ max}} = 1000 \text{ mm}$$

#### Stay width:

$$B_{St} = B_i + 33 \text{ mm}$$

$$B_{St} = B_k - 29 \text{ mm}$$

### Intrinsic chain weight

for two band chains  
depending on the chain width.

Weight of the chain bands:  
22.8 kg/m (excluding stays)

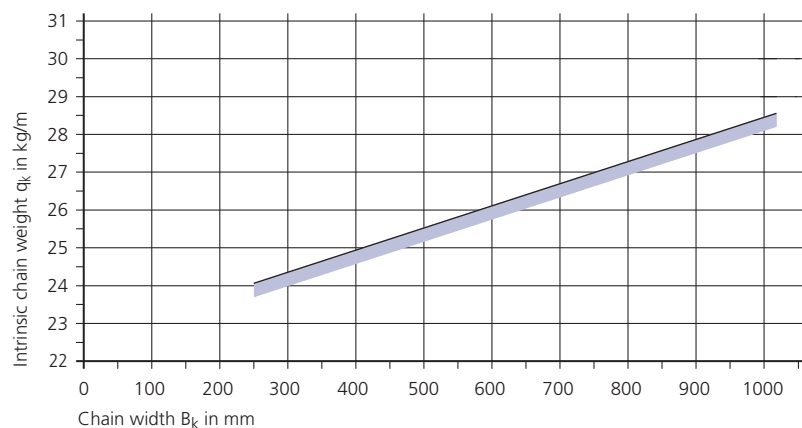

### Divider system TS 0 for stay variant RM

The dividers are **movable**.

$s_T$	= 7.5 mm
$a_{T \text{ min}}$	= 21.5 mm
$a_{x \text{ min}}$	= 25 mm

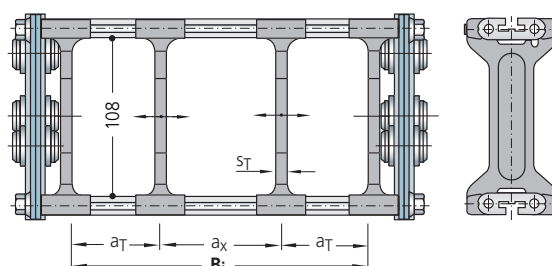

Example for ordering  
– divider system TS 0

<b>TS 0</b>	/	<b>2</b>
Divider system		Number of dividers $n_T$

# Type S 1800 / SX 1800

## Stay variant RM – frame stay, reinforced design

### Divider system TS 3 for stay variant RM:

#### Section subdivision with partitions made of plastic or aluminium

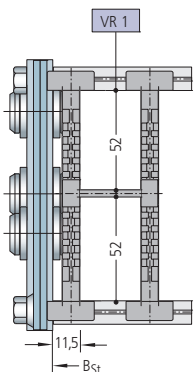
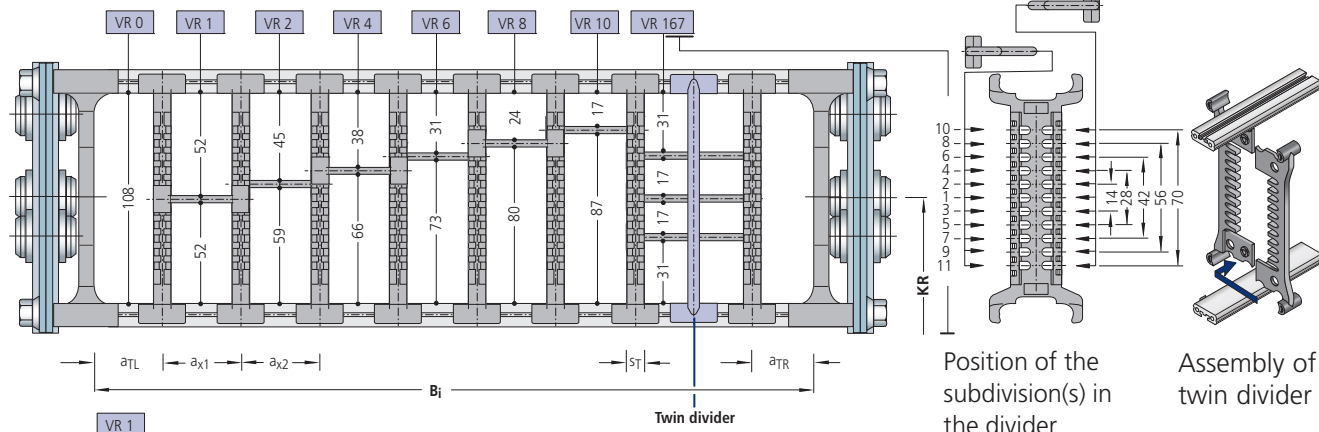

The dividers are fixed by the partitions, the complete divider system is movable. Optional movable **twin dividers** ( $s_T = 5 \text{ mm}$ ) are available. Twin dividers can also be assembled at a later date.

Dimensions without VR 0 chamber at the edge. The outer dividers replace the peripheral dividers.

$s_T$	= 8 mm
$a_T \text{ min}$	= 1 mm
$a_x \text{ min}$	= see partitions dimensions
$n_T \text{ min}$	= 2

#### Example for ordering – divider system TS 3 with partitions made of plastic

TS 2	-	K 1	-	VR 0	/	34
Divider system		Chamber		Variant of the height subdivision in chamber		Installation interval (mm)
		K 2		VR 1	/	38

Please state the chambers from left to right and the dimensions  $a_T/a_x$  when ordering. Possibly enclose a sketch with dimensions. Please state additional twin dividers when ordering.

## Dimensions of the partitions for TS 3

### Partitions made of plastic (Standard)

Dimensions in mm

$a_x$ (Center to center distance, dividers)									
16	18	23	28	32	33	38	43	48	58
64	68	78	80	88	96	112	128	144	160
176	192	208							



When using **partitions with  $a_x > 112 \text{ mm}$** , there must be an additional central support with a **twin divider**. Twin dividers are suitable for subsequent installation in the partition system.

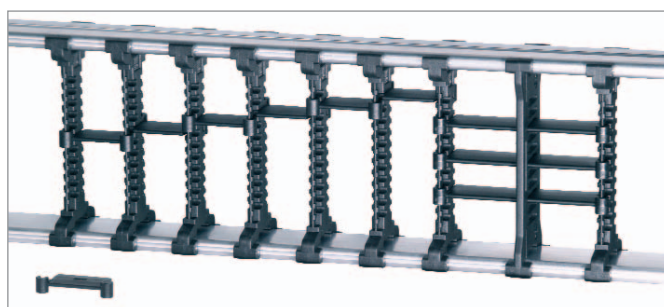

**Alternatively**, partitions made of aluminium in 1 mm section widths ( $a_x \text{ min} = 42 \text{ mm}$ ) are also available.





## Type S 1800 / SX 1800

### Stay variant RR – frame stay, tube design

- gentle cable support due to rotating metal tubes
- ideal when using media hoses with "soft" sheaths
- possible materials of the axles, tubes and dividers:
  - axles, tubes and dividers made of zinc-plated steel (**Standard**)
  - axles, tubes and dividers made of stainless steel ER 1, ER 1S
- Standard stay arrangement:** on every 2nd chain link. Stays can be fitted on every chain link, please specify when placing your order.
- bolted stays for maximum stability

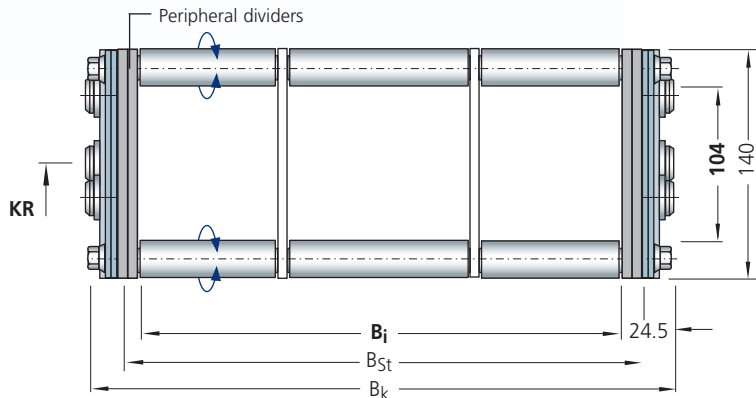
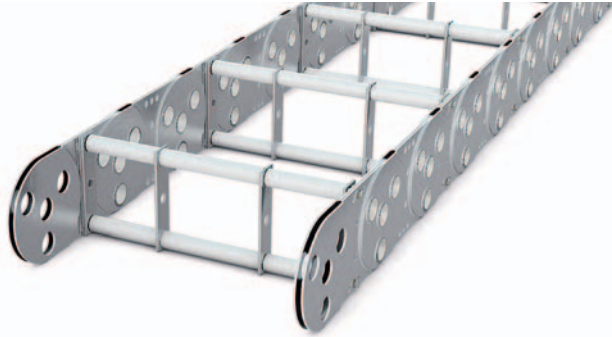

All chain cross sections according to sectional information in the schematic illustration.

The peripheral dividers are an integral part of the stay system and must not be ordered separately.

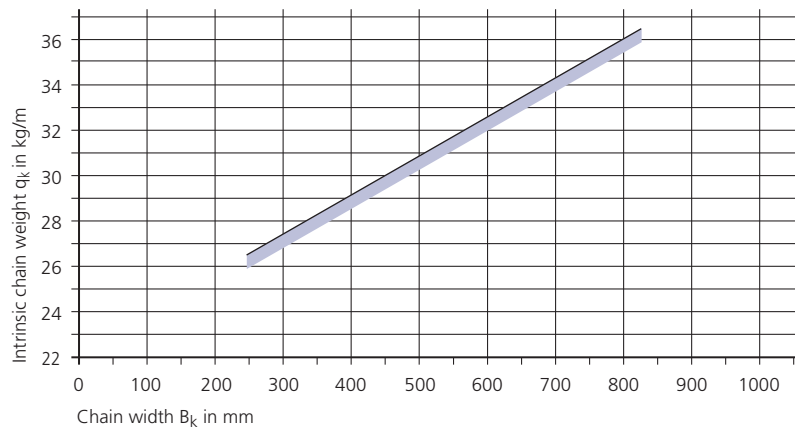

**Chain width:**  
 $B_k = B_i + 49 \text{ mm}$

$B_{k \text{ min}} = 250 \text{ mm}$   
 $B_{k \text{ max}} = 800 \text{ mm}$

**Stay width:**  
 $B_{St} = B_i + 20 \text{ mm}$   
 $B_{St} = B_k - 29 \text{ mm}$

### Intrinsic chain weight

for two band chains  
depending on the chain width.

Weight of the chain bands:  
22.8 kg/m (excluding stays)

### Divider systems TS 0 and TS 1 for stay variant RR

The dividers are **fixed**.

**TS 0:** without height subdivision

**TS 1:** with continuous centric height subdivision

$s_T$	= 5 mm
$a_T \text{ min}$	= 45 mm
$a_x \text{ min}$	= 45 mm

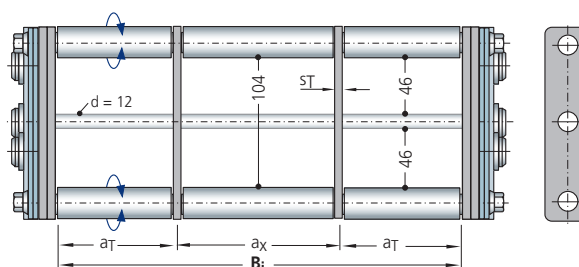

**Example for ordering – divider system**

<b>TS 0</b>	/	<b>2</b>
Divider system		Number of dividers $n_T$

Please state the dimensions  $a_T/a_x$  when ordering. Possibly enclose a sketch with dimensions.

## Type S 1800 / SX 1800

### Stay variant LG – hole stay made of aluminium, split design

- optimum cable guidance in the neutral bending line is possible
- drilling pattern individually adapted to the application
- high stability due to solid construction
- split design as standard for easy laying of the cables
- **Standard stay arrangement:**  
on every 2nd chain link.  
Stays can be fitted on every chain link, please specify when placing your order.
- bolted stays for maximum stability  
– also available not split

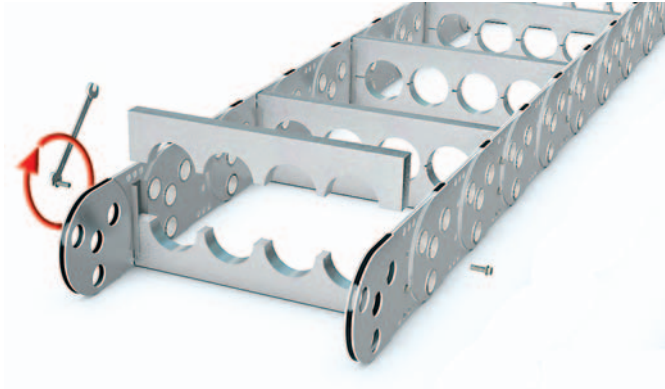

#### Chain width:

$$B_k = \sum D + \sum c + 59 \text{ mm}$$

$$B_k \text{ min} = 180 \text{ mm}$$

$$B_k \text{ max} = 1000 \text{ mm}$$

#### Stay width:

$$B_{St} = \sum D + \sum c + 27 \text{ mm}$$

$$B_i = B_{St} - 2 a_0$$

$$B_{St} = B_k - 32 \text{ mm}$$

$$D_{\text{max}} = 110 \text{ mm}$$

$$c_{\text{min}} = 4 \text{ mm}$$

$$a_{0 \text{ min}} = 13.5 \text{ mm}$$

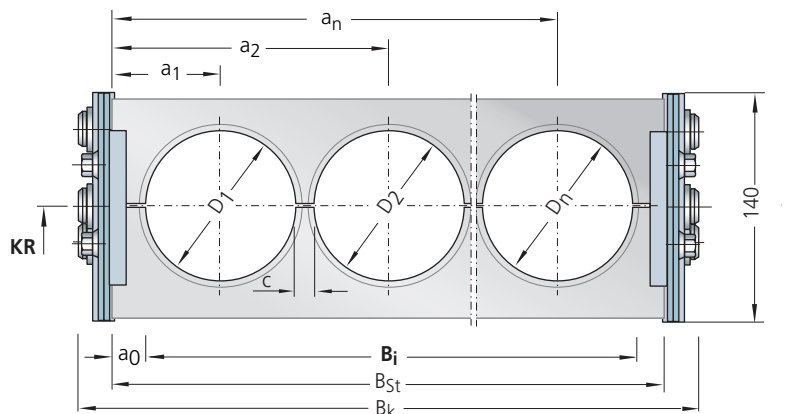

All chain cross sections according to sectional information in the schematic illustration.

### Intrinsic chain weight

#### for two band chains

depending on the chain width.

Hole area of the hole stay is approx. 50 %

Weight of the chain bands:  
22.8 kg/m (excluding stays)

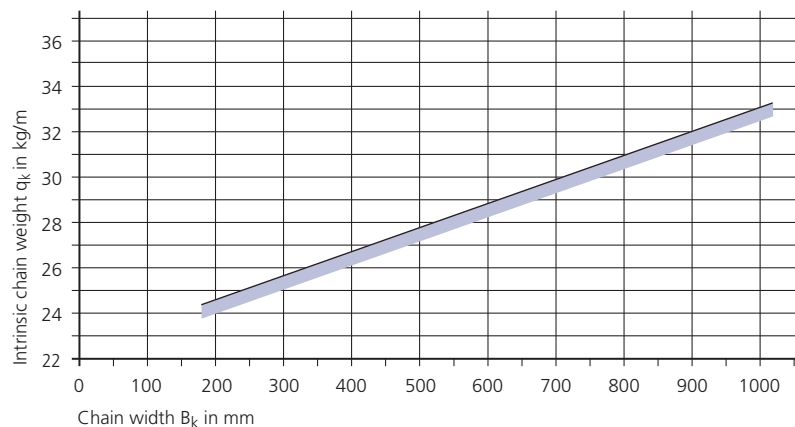

## Type S 1800 / SX 1800

### Stay variant RMD – covered cable carrier, STEEL-TUBE

- **aluminium cover system** for protecting the cables and hoses
- for applications where chips or severe contamination occur
- bolted aluminium cover for maximum stability



Steel band covers are also available as light-weight, economically priced alternatives to covering with the aluminium cover system, see page 172.



#### Chain width:

$$B_k = B_i + 62 \text{ mm}$$

$$B_{k \text{ min}} = 250 \text{ mm}$$

$$B_{k \text{ max}} = 1000 \text{ mm}$$

#### Stay width:

$$B_{St} = B_i + 33 \text{ mm}$$

$$B_{St} = B_k - 29 \text{ mm}$$

#### Minimum bend radius

$$KR_{\text{min}} = 320 \text{ mm}$$

#### Intrinsic chain weight

for two band chains

depending on the chain width.

Weight of the chain bands:  
22.8 kg/m (excluding stays)

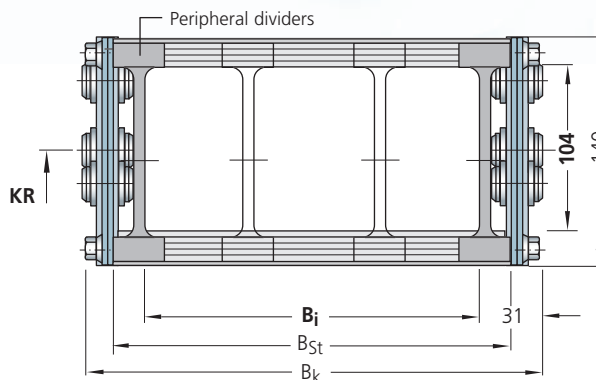

All chain cross sections according to sectional information in the schematic illustration.

The peripheral dividers are an integral part of the stay system and must not be ordered separately.

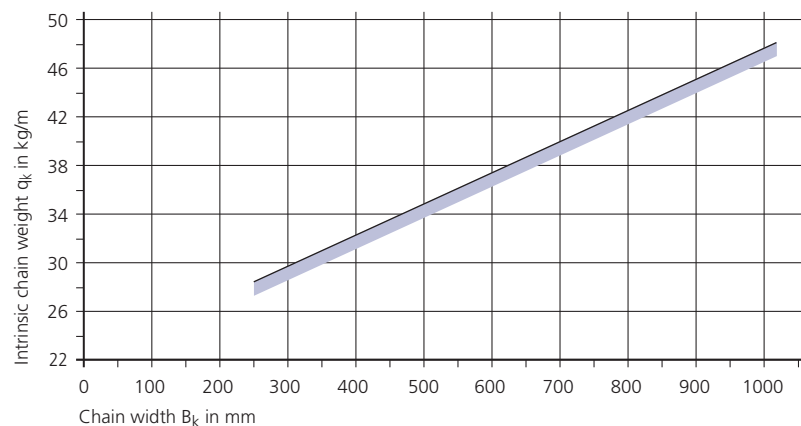

#### Divider system TS 0 for stay variant RMD

The dividers are **movable**.

$s_T$	= 7.5 mm
$a_{T \text{ min}}$	= 21.5 mm
$a_{x \text{ min}}$	= 25 mm

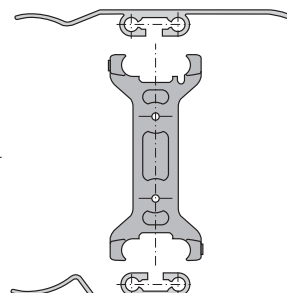
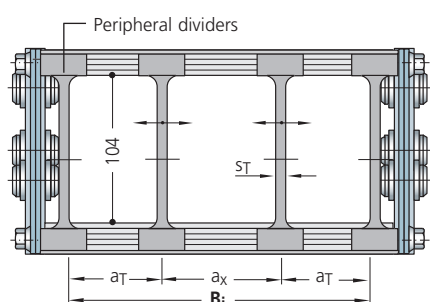

**Example for ordering – divider system TS 0**

<b>TS 0</b>	/	<b>2</b>
Divider system		Number of dividers $n_T$

# Type S 1800 / SX 1800

## Fixed point connection

### Connection variant FA

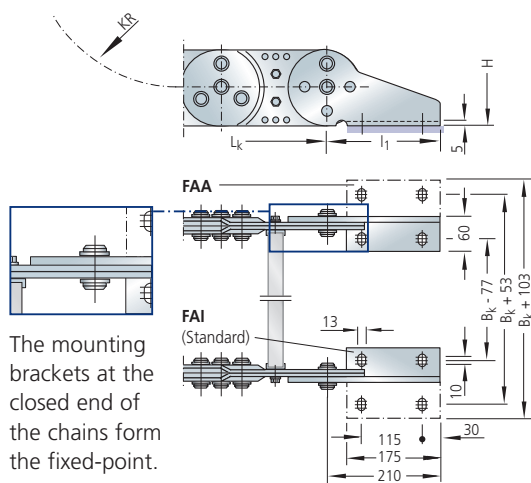

The mounting brackets at the closed end of the chains form the fixed-point.

### Connection variant FI

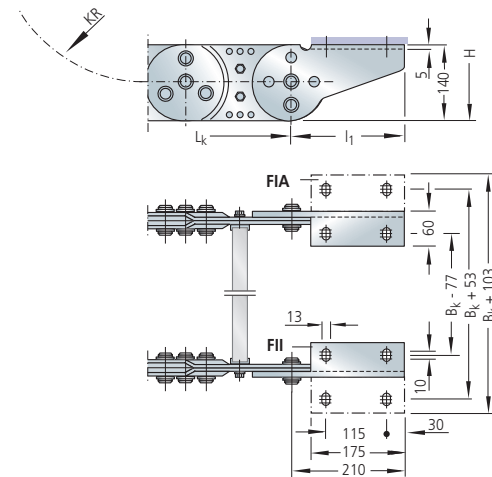

### Connection variant FH

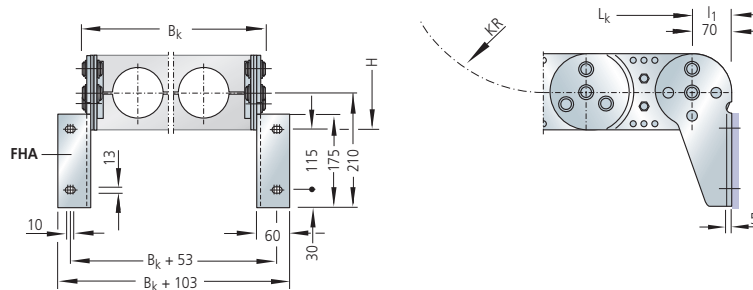

### Connection variant FK

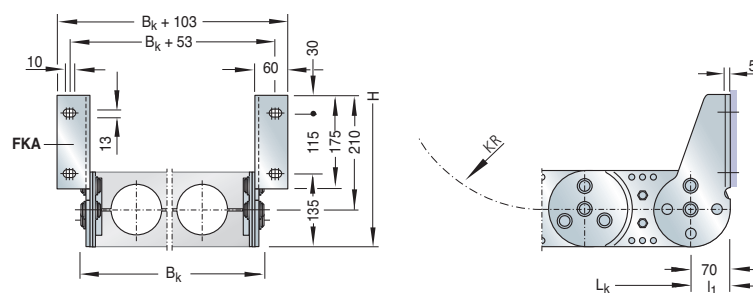

Different connection variants for fixed point and driver are possible according to the drawing information and are realized by different assembly of the connecting pieces.

The connection variants can also be changed at a later date if required.

Please state the desired connection variant according to the ordering key (see page 130).

### Type S 1800 / SX 1800

#### Driver connection

##### Connection variant MA

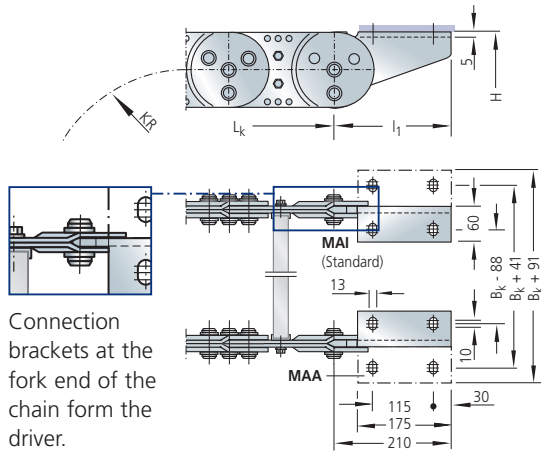

##### Connection variant MI

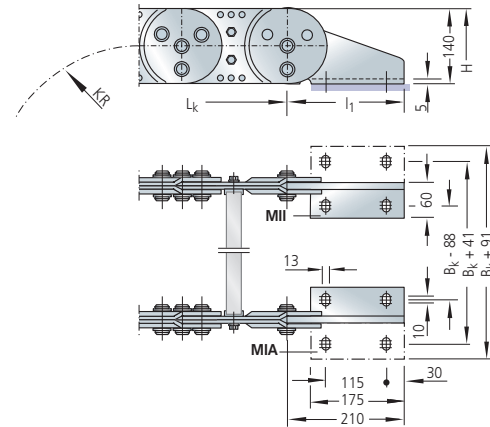

##### Connection variant MH

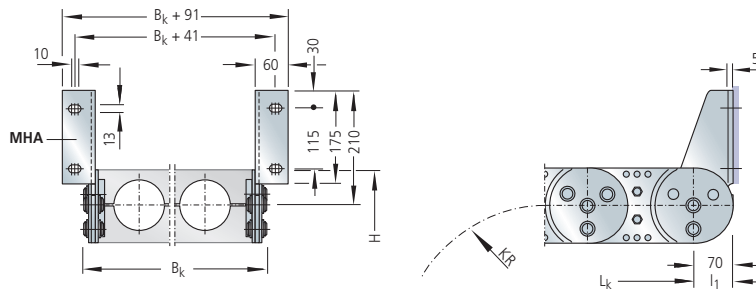

##### Connection variant MK

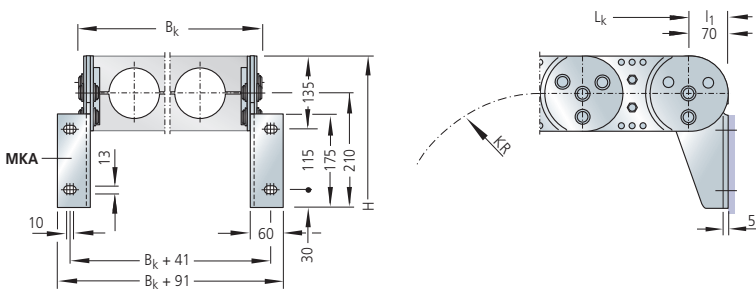

# Type S 1800 / SX 1800

## Ordering – cable carrier

Cable Carrier					
<b>S 1800</b>	<b>450</b>	<b>RM</b>	<b>375</b>	<b>St</b>	<b>5940</b>
Type	Stay width B <sub>St</sub> in mm	Stay variant	Bend radius KR in mm	Chain band material	Chain length L <sub>k</sub> in mm (with- out connection)

### Chain band materials:

- St = zinc-plated steel
- ER 1 = stainless steel
- ER 1S = sea water resistant stainless steel
- ER 2 = high-strength stainless steel

More information:  
See material overview on page 54.

## Ordering – divider system

Divider system	
<b>TS 0</b>	<b>4</b>
Divider system	Number of dividers n <sub>T</sub>

See also the sample order for the respective divider system.

## Ordering – connection

Connection					
<b>F</b>	<b>A</b>	<b>A</b>	<b>M</b>	<b>K</b>	<b>A</b>
Fixed point	Connection type	Connection surface	Driver	Connection type	Connection surface

If no order designation for the connection is stated, we supply the connection variant **FAI/MAI (Standard)**.

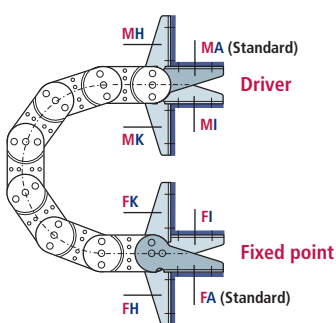

- F** – Fixed point
- M** – Driver
- Connection type**
- A** – Bolts facing outward (Standard)
- I** – Bolts facing inward
- H** – Threaded joint, rotated by 90° to the outside
- K** – Threaded joint, rotated by 90° to the inside

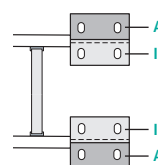

- Connection surface**
- I** – Connector surface inside (< B<sub>k</sub>)
- A** – Connector surface outside (> B<sub>k</sub>)

The connecting surfaces on the driver and fixed point can be mounted on the outside or inside according to preference.

The connection type can easily be altered at a later date.

Guide channels  
➤ from page 166

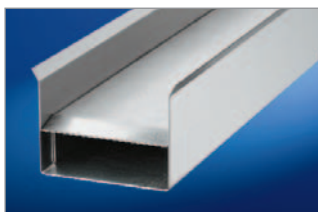

Strain relief devices  
➤ from page 173



Cables for cable carrier systems  
➤ in our TRAXLINE Cables for Motion catalogue.





## Type S 2500

Steel chain bands

## Type SX 2500

Stainless steel chain bands

### Materials

Chain bands and end connectors:

**S 2500:** Steel, zinc-plated

**SX 2500:** grade rust and acid resistant steel

Standard stay material: aluminium alloy\*

Dividers: plastic

→ see material properties, page 54

**STEEL**  
ZINC-PLATED  
**STAINLESS**  
STEEL  
RUST-FREE

2D/3D-Data  
[kabelschlepp.de/cad-gb](http://kabelschlepp.de/cad-gb)

### Chain width

customer-specific

available in 1 mm width sections

WIDTHSECTIONS  
← 1 mm →

### Chain pitch

250 mm

### Bend radii

various **standard bend radii** from 365 – 1395 mm;  
intermediate radii upon request

\* See description for the respective stay variant for details.

### Stay variant RM



Clearance height  $h_j = 183$  mm

➤ from page 133

### Stay variant LG



max. hole  $\varnothing = 180$  mm

➤ from page 134

Stay variant RR is possible as a special design.  
Please contact us.

# Type S 2500 / SX 2500

## Rolling schematic illustration unsupported arrangement

- Chain pitch  $t = 250 \text{ mm}$
- Height  $h_G = 220 \text{ mm}$
- Connection height  $H = 2 \text{ KR} + 330 \text{ mm}$  (unsupported)
- Connection length  $l_1 = 300 \text{ mm}$   
(see connection dimensions)

A flat and level surface is required for the cable carrier to extend and retract reliably.  
Under certain conditions, a support tray needs to be installed (see page 169).

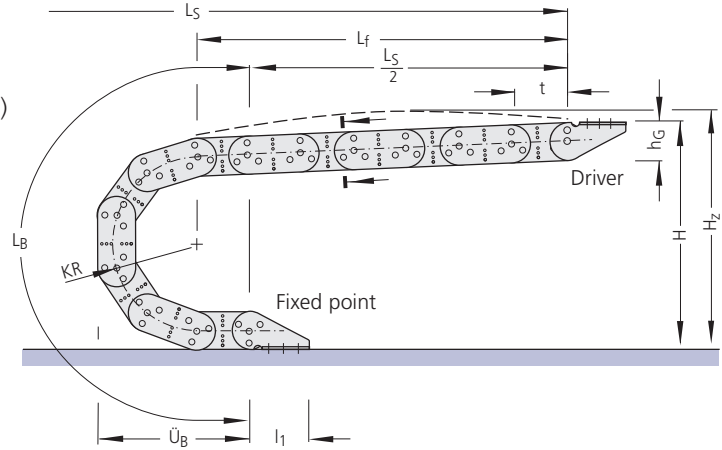

### Variable sizes

depending on the bend radius

Dimensions in mm

Bend radius	365	445	600	760	920	1075	1235	1395
Bend length $L_B$	2147	2398	2885	3388	3890	4377	4880	5383
Bend overhang $\ddot{U}_B$	975	1055	1210	1370	1530	1685	1845	2005
Height $H$ (unsupported)	1060	1220	1530	1850	2170	2480	2800	3120

**Chain length:**

$$L_k \approx \frac{L_s}{2} + L_B$$

rounded to pitch 250 mm

**Installation height\*:**

$$H_z = H + z$$

Pre-tension  $z \approx 10 \text{ mm/m}$  chain length  
\* required clear height

## Load diagramm

### Unsupported length $L_f$ and travel length $L_s$ without support

depending on the additional load (see design guidelines).

Load diagram for an intrinsic chain weight  $q_k$  of 41 kg/m.

If the intrinsic chain weight  $q_k$  of 41 kg/m is exceeded, the permissible additional load is reduced by the difference.

For circular operations, combinations of KR/RKR are possible.  
Please contact us for details.

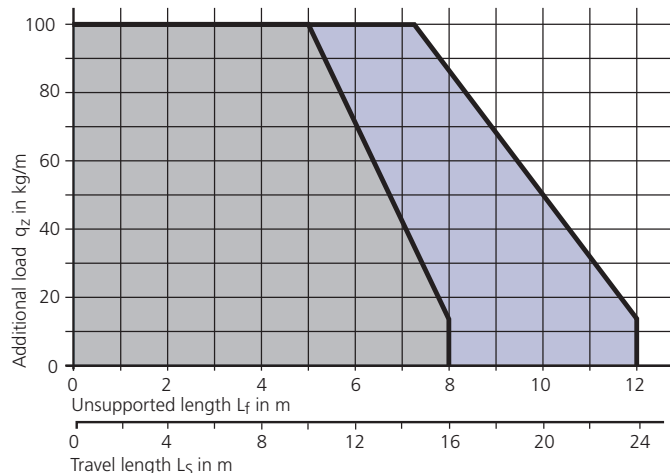

- S 2500 material zinc-plated steel
- SX 2500 material ER 2
- SX 2500 material ER 1 / ER 1S



## Type S 2500 / SX 2500

### Stay variant RM – frame stay, solid design

- frame stay RM made of aluminium – solid design
- for heavy loads – maximum chain widths possible
- **Standard stay arrangement:** on every 2nd chain link. Stays can be fitted on every chain link, please specify when placing your order.
- bolted stays for maximum stability

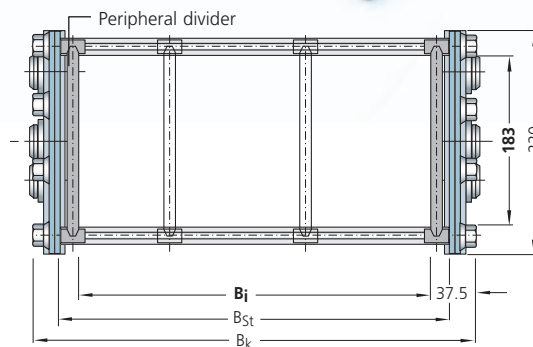
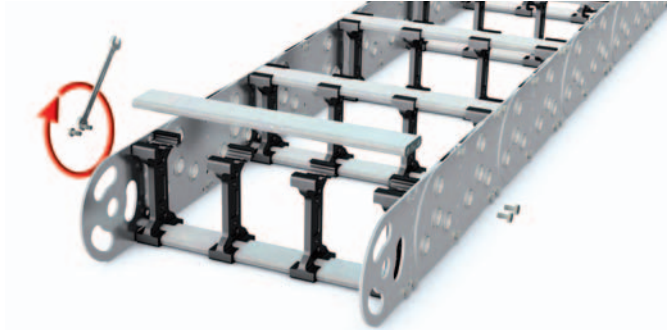

All chain cross sections according to sectional information in the schematic illustration.

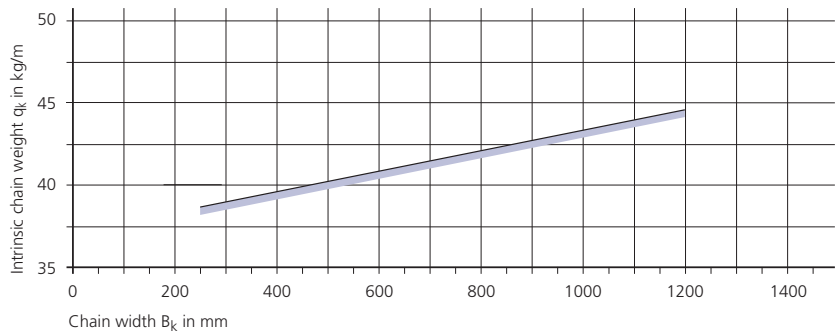

### Intrinsic chain weight

for two band chains  
depending on the chain width.

Weight of the chain bands:  
36 kg/m (excluding stays)

### Divider system TS 0 for stay variant RM

The dividers are **movable**.

$s_T$	= 12 mm
$a_{T \min}$	= 19 mm
$a_{x \min}$	= 25 mm

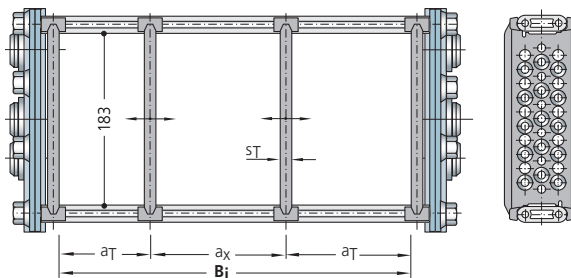

Example for ordering  
– divider system TS 0

<b>TS 0</b>	/	<b>2</b>
Divider system		Number of dividers $n_T$

### Divider systems TS 1 and TS 2 for stay variant RM

Divider systems TS 1 and TS 2 are available on request.

Please contact us.



# Type S 2500 / SX 2500

## Stay variant LG – hole stay made of aluminium, split design

- optimum cable guidance in the neutral bending line is possible
- drilling pattern individually adapted to the application
- high stability due to solid construction
- split design as standard for easy laying of the cables
- **Standard stay arrangement:**  
on every 2nd chain link.  
Stays can be fitted on every chain link, please specify when placing your order.
- bolted stays for maximum stability

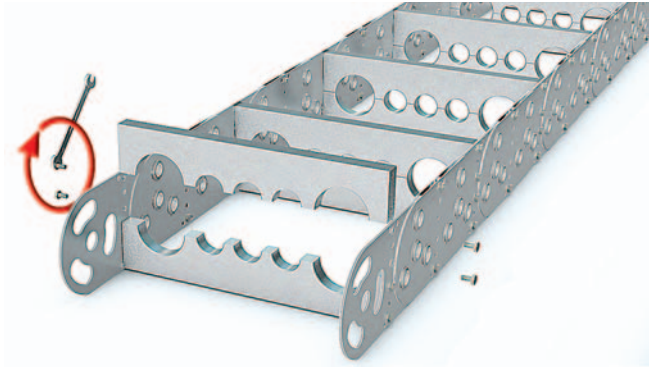

### Chain width:

$$B_k = \sum D + \sum c + 76 \text{ mm}$$

$$B_{k \text{ min}} = 250 \text{ mm}$$

$$B_{k \text{ max}} = 1200 \text{ mm}$$

### Stay width:

$$B_{St} = \sum D + \sum c + 44 \text{ mm}$$

$$B_i = B_{St} - 2 a_0$$

$$B_{St} = B_k - 32 \text{ mm}$$

$$D_{\text{max}} = 180 \text{ mm}$$

$$c_{\text{min}} = 4 \text{ mm}$$

$$a_{0 \text{ min}} = 22 \text{ mm}$$

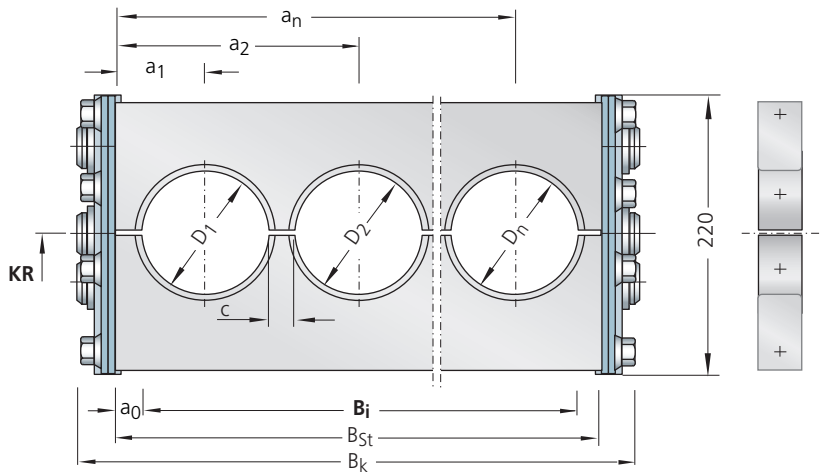

All chain cross sections according to sectional information in the schematic illustration.

## Intrinsic chain weight

### for two band chains

depending on the chain width.

Hole area of the hole stay is approx. 50 %

Weight of the chain bands:  
36 kg/m (excluding stays)

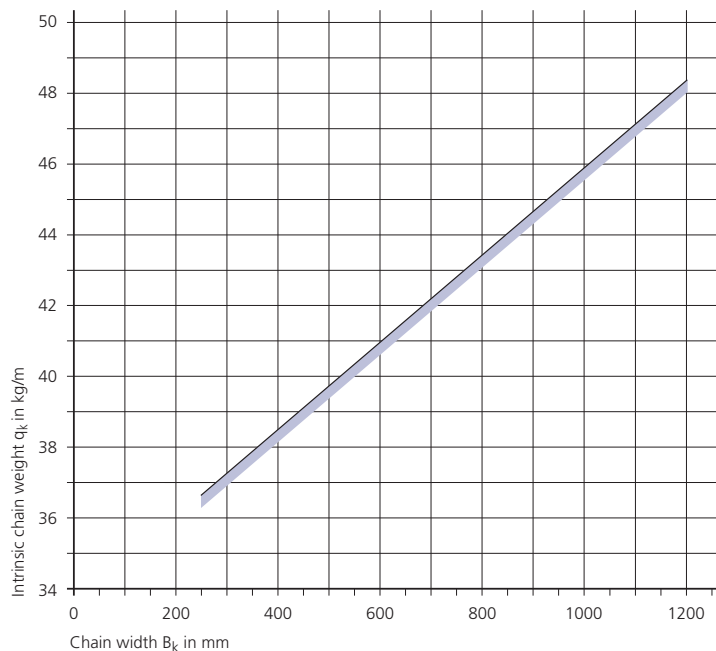

## Type S 2500 / SX 2500

### Fixed point connection

#### Connection variant FA

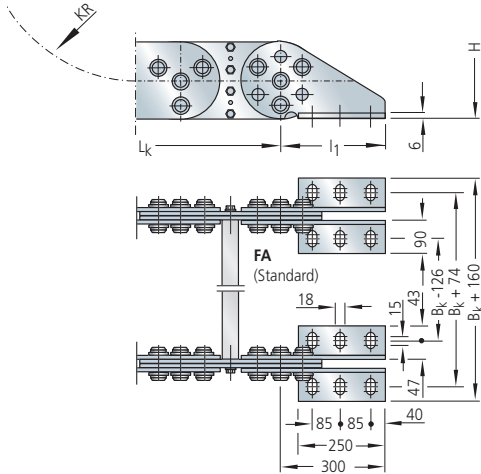

#### Connection variant FI

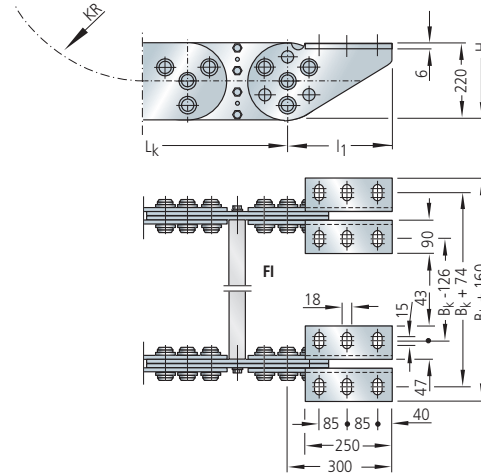

### Driver connection

#### Connection variant MA

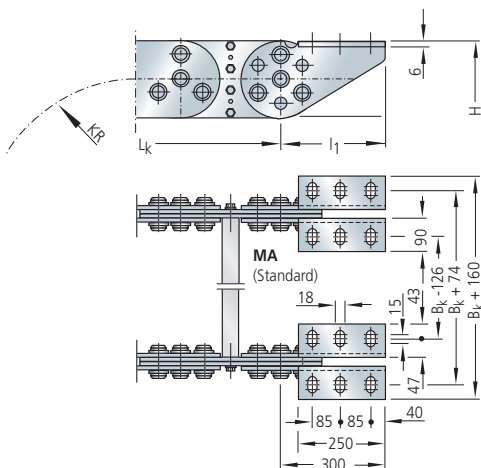

#### Connection variant MI

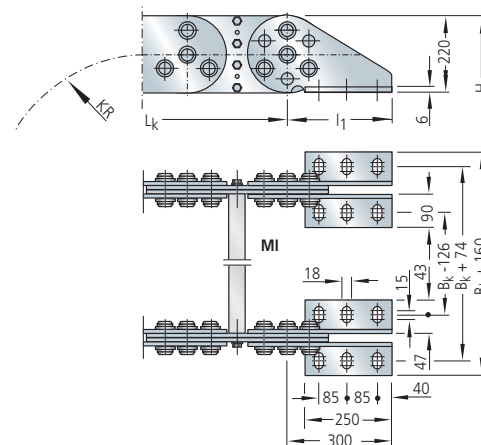

Driver and fixed point connection using double end connectors on the inside link plates.

Different connection variants for fixed point and driver are possible according to the drawing information and are realized by different assembly of the connecting pieces.

The connection variants can also be changed at a later date if required.

Please state the desired connection variant according to the ordering key (see page 136).

## Type S 2500 / SX 2500

### Ordering – cable carrier

Cable Carrier					
<b>S 2500</b>	<b>850</b>	<b>LG</b>	<b>760</b>	<b>ER 1</b>	<b>9250</b>
Type	Stay width B <sub>St</sub> in mm	Stay variant	Bend radius KR in mm	Chain band material	Chain length L <sub>k</sub> in mm (with- out connection)

#### Chain band materials:

St = zinc-plated steel  
 ER 1 = stainless steel  
 ER 1S = sea water resistant stainless steel  
 ER 2 = high-strength stainless steel

More information:  
 See material overview on page 54.

### Ordering – divider system

Divider system	
<b>TS 0</b>	<b>4</b>
Divider system	Number of dividers n <sub>T</sub>

See also the sample order for the respective divider system.

### Ordering – connection

Connection			
<b>F</b>	<b>I</b>	<b>M</b>	<b>A</b>
Fixed point	Connection type	Driver	Connection type

If no order designation for the connection is stated, we supply the connection variant **FAI/MAI (Standard)**.

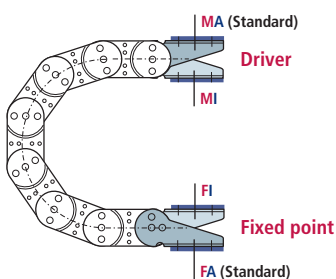

**F** – Fixed point  
**M** – Driver  
**Connection type**  
**A** – Bolts facing outward (Standard)  
**I** – Bolts facing inward

Guide channels  
 ➤ from page 166

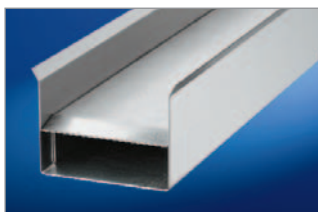

Strain relief devices  
 ➤ from page 173



Cables for cable carrier systems  
 ➤ in our TRAXLINE Cables for Motion catalogue.





## Type S 3200

Steel chain bands

## Type SX 3200

Stainless steel chain bands

### Materials

Chain bands and end connectors:

**S 3200:** Steel, zinc-plated

**SX 3200:** grade rust and acid resistant steel

Standard stay material: aluminium alloy

→ see material properties, page 54

**STEEL**  
ZINC-PLATED  
**STAINLESS**  
**STEEL**  
RUST-FREE

2D/3D-Data  
[kabelschlepp.de/cad-gb](http://kabelschlepp.de/cad-gb)

### Chain width

customer-specific

available in 1 mm width sections

WIDTH SECTIONS  
1 mm

### Chain pitch

320 mm

### Bend radii

various standard bend radii

from 470 – 1785 mm;

intermediate radii upon request

### Stay variant LG



max. hole  $\varnothing = 220$  mm

► from page 139

Stay variant RR is possible as a special design.  
Please contact us.

# Type S 3200 / SX 3200

## Rolling schematic illustration unsupported arrangement

- Chain pitch  $t = 320 \text{ mm}$
- Height  $h_G = 300 \text{ mm}$
- Connection height  $H = 2 \text{ KR} + 450 \text{ mm}$  (unsupported)
- Connection length  $l_1 = 350 \text{ mm}$   
(see connection dimensions)

A flat and level surface is required for the cable carrier to extend and retract reliably.  
Under certain conditions, a support tray needs to be installed (see page 169).

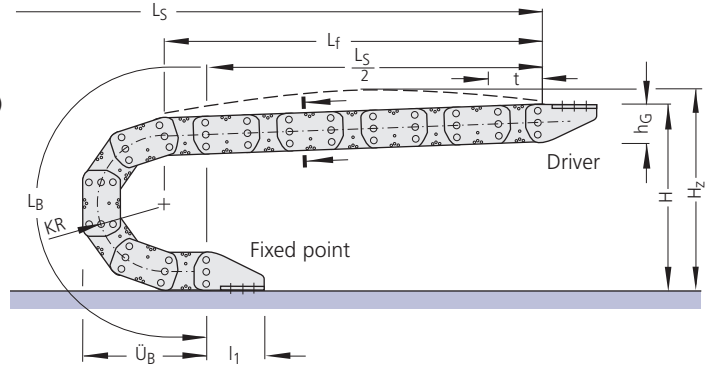

### Variable sizes

depending on the bend radius

Bend radius	Dimensions in mm						
	470	670	870	1075	1275	1480	1785
Bend length $L_B$	2757	3385	4013	4657	5286	5930	6888
Bend overhang $\ddot{U}_B$	1260	1460	1660	1865	2065	2270	2575
Height $H$ (unsupported)	1390	1790	2190	2600	3000	3410	4020

**Chain length:**

$$L_k \approx \frac{L_s}{2} + L_B$$

rounded to pitch 320 mm

**Installation height\*:**

$$H_z = H + z$$

Pre-tension  $z \approx 10 \text{ mm/m}$  chain length  
\* required clear height

## Load diagramm

### Unsupported length $L_f$ and travel length $L_s$ without support

depending on the additional load (see design guidelines).

Load diagram for an intrinsic chain weight  $q_k$  of 62 kg/m.

If the intrinsic chain weight  $q_k$  of 62 kg/m is exceeded, the permissible additional load is reduced by the difference.

For circular operations, combinations of KR/RKR are possible.  
Please contact us for details.

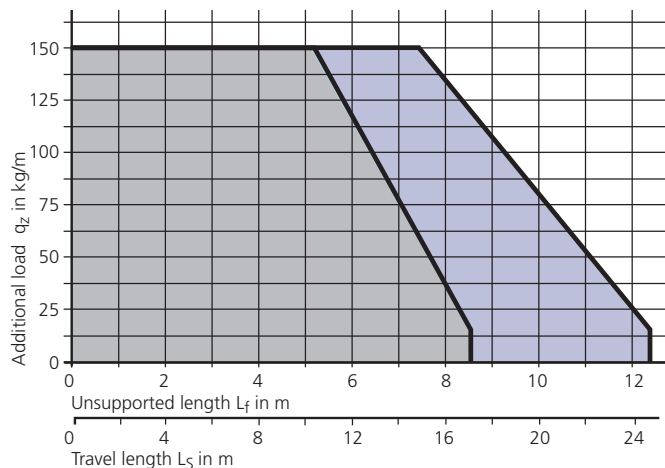

- S 3200 material zinc-plated steel
- SX 3200 material ER 2
- SX 3200 material ER 1 / ER 1S

## Type S 3200 / SX 3200

### Stay variant LG – hole stay made of aluminium, split design

- optimum cable guidance in the neutral bending line is possible
- drilling pattern individually adapted to the application
- high stability due to solid construction
- split design as standard for easy laying of the cables
- **Standard stay arrangement:**  
on every 2nd chain link.  
Stays can be fitted on every chain link, please specify when placing your order.
- bolted stays for maximum stability

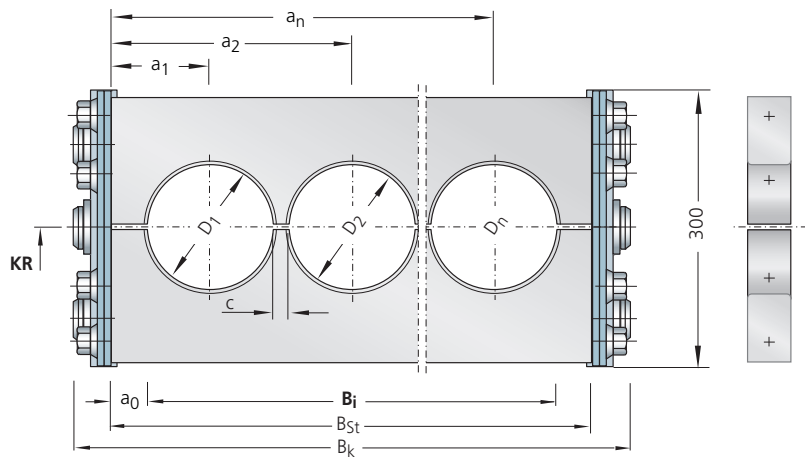
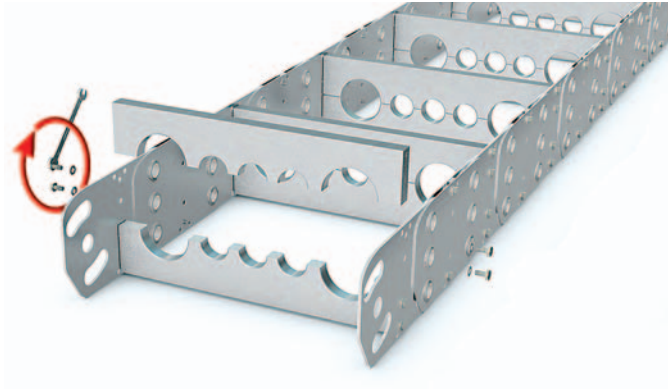

All chain cross sections according to sectional information in the schematic illustration.

#### Chain width:

$$B_k = \sum D + \sum c + 84 \text{ mm}$$

$$B_{k \text{ min}} = 250 \text{ mm}$$

$$B_{k \text{ max}} = 1500 \text{ mm}$$

#### Stay width:

$$B_{St} = \sum D + \sum c + 44 \text{ mm}$$

$$B_i = B_{St} - 2 a_0$$

$$B_{St} = B_k - 40 \text{ mm}$$

$$D_{\text{max}} = 220 \text{ mm}$$

$$c_{\text{min}} = 4 \text{ mm}$$

$$a_{0 \text{ min}} = 22 \text{ mm}$$

### Intrinsic chain weight

#### for two band chains

depending on the chain width.

Hole area of the hole stay is approx. 50 %

Weight of the chain bands:  
55 kg/m (excluding stays)

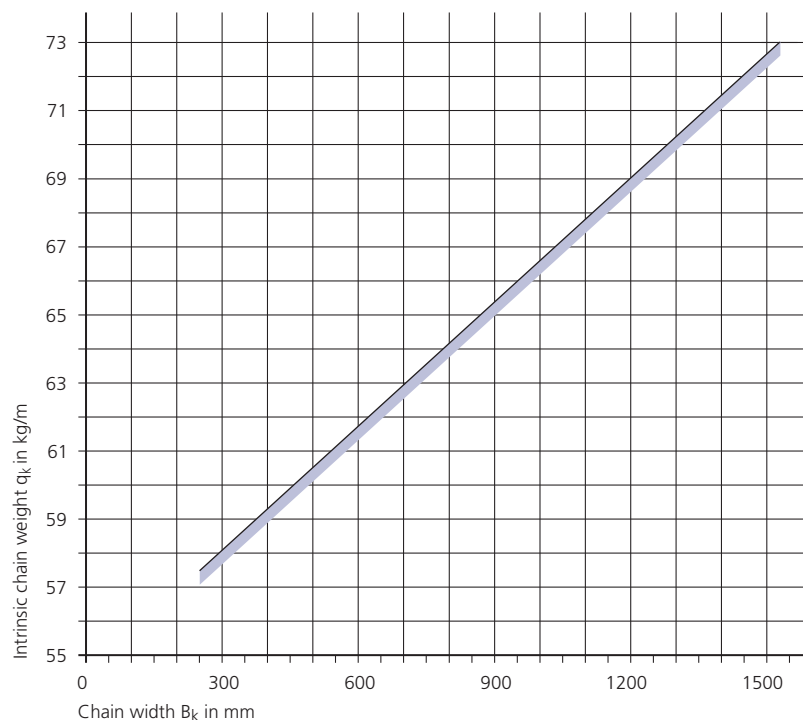

# Type S 3200 / SX 3200

## Fixed point connection

### Connection variant FA

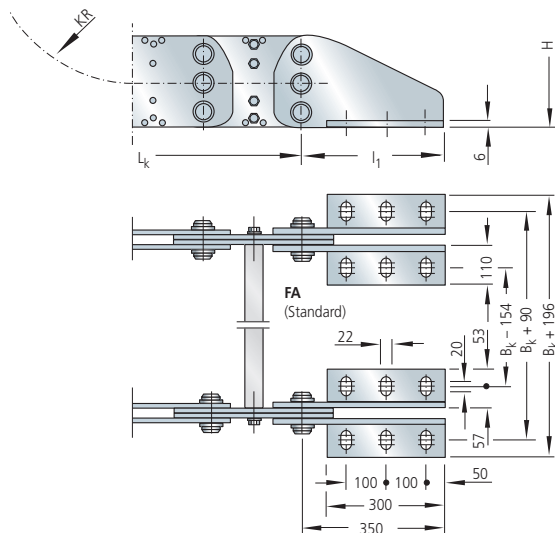

### Connection variant FI

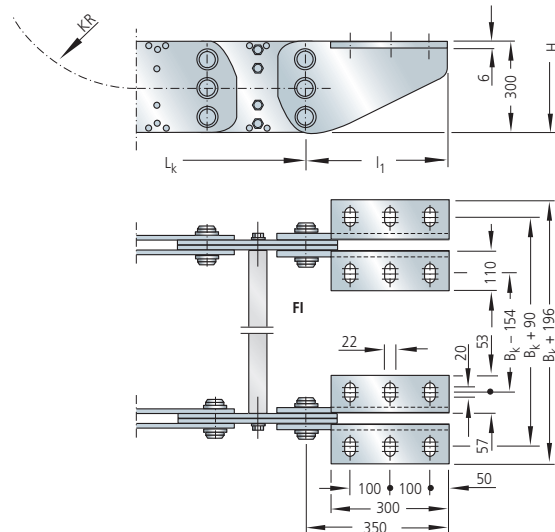

## Driver connection

### Connection variant MA

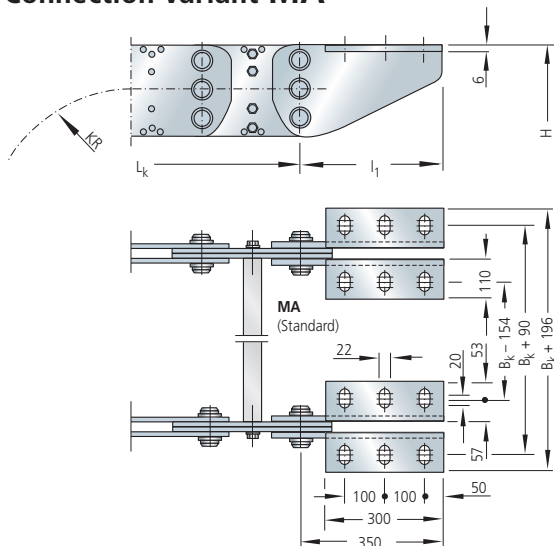

### Connection variant MI

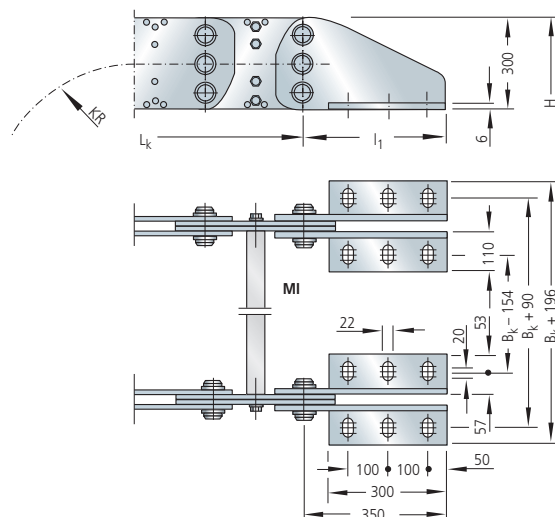

### Driver and fixed point connection using double end connectors on the inside link plates.

Different connection variants for fixed point and driver are possible according to the drawing information and are realized by different assembly of the connecting pieces.

The connection variants can also be changed at a later date if required.

Please state the desired connection variant according to the ordering key (see page 141).



## Type S 3200 / SX 3200

### Ordering – cable carrier

Cable Carrier					
<b>S 3200</b>	<b>820</b>	<b>LG</b>	<b>1075</b>	<b>ER 1</b>	<b>9280</b>
Type	Stay width B <sub>St</sub> in mm	Stay variant	Bend radius KR in mm	Chain band material	Chain length L <sub>k</sub> in mm (with- out connection)

#### Chain band materials:

- St = zinc-plated steel
- ER 1 = stainless steel
- ER 1S = sea water resistant stainless steel
- ER 2 = high-strength stainless steel

More information:  
See material overview on page 54.

### Ordering – connection

Connection			
<b>F</b>	<b>I</b>	<b>M</b>	<b>A</b>
Fixed point	Connection type	Driver	Connection type

If no order designation for the connection is stated, we supply the connection variant **FAI/MAI (Standard)**.

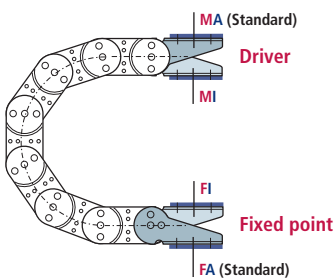

- F** – Fixed point
- M** – Driver
- Connection type**
- A** – Bolts facing outward (Standard)
- I** – Bolts facing inward

Guide channels  
➤ from page 166

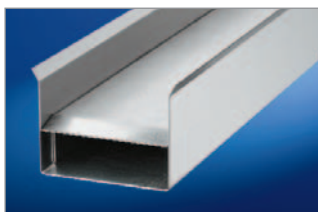

Strain relief devices  
➤ from page 173



Cables for cable carrier systems  
➤ in our TRAXLINE Cables for Motion catalogue.





Cable Carrier for **Offshore**-applications

## Type S 5000/6000/7000

Steel chain bands

## Type SX 5000/6000/7000

Stainless steel chain bands



■ Steel cable carriers, in the delivery condition with transport frame



### Materials

Chain bands and end connectors:

**S 5000 / 6000 / 7000:**

Steel, zinc-plated

**SX 5000 / 6000 / 7000:**

grade rust and acid resistant steel

Standard stay material: aluminium alloy

→ see material properties, page 54



### Chain width

customer-specific

available in 1 mm width sections

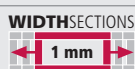

### Chain pitch

S/SX 5000: 200 mm / S/SX 6000: 320 mm / S/SX 7000: 450 mm

### Bend radii

various standard bend radii

from 500 – 2400 mm; intermediate radii upon request

For applications with extremely large additional loads and very large chain dimensions.

Cable carriers of the types 5000 / 6000 / 7000 are usually special designs for special applications such as, e.g. in the offshore area.

## Type S/SX 5000 / 6000 / 7000

### Rolling schematic illustration unsupported arrangement

Type	S/SX 5000	S/SX 6000	S/SX 7000
Chain pitch T	200	320	450
Height $h_G$	200	300	450
Connection height H (unsupported)	$2 KR + 1.5 h_G$		
Connection length $l_1$	75	125	200

A flat and level surface is required for the cable carrier to extend and retract reliably. Under certain conditions, a support tray needs to be installed (see page 169).

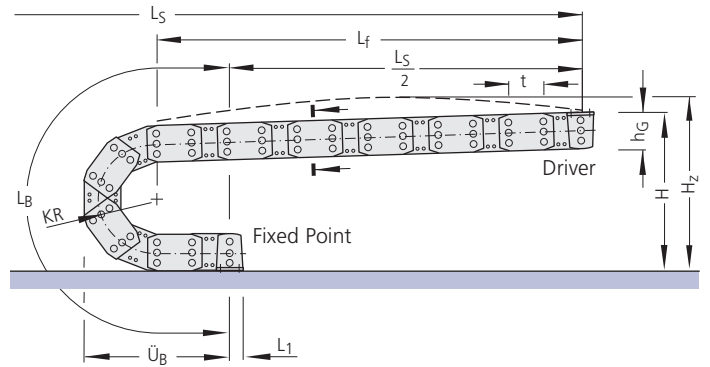

### Variable sizes

depending on the bend radius

#### Type S/SX 5000

Dimensions in mm

Bend radius	500	600	800	1000	1200
Bend length $L_B$	2370	2685	3315	3940	4570
Bend overhang $\ddot{U}_B$	1075	1175	1375	1575	1775
Height H (unsupported)	1300	1500	1900	2300	2700

#### Type S/SX 6000

Dimensions in mm

Bend radius	700	900	1100	1300	1500
Bend length $L_B$	3480	4110	4735	5365	5995
Bend overhang $\ddot{U}_B$	1615	1815	2015	2215	2415
Height H (unsupported)	1850	2250	2650	3050	3450

#### Type S/SX 7000

Dimensions in mm

Bend radius	1100	1250	1500	1800	2400
Bend length $L_B$	5255	5725	6510	7450	9335
Bend overhang $\ddot{U}_B$	2425	2575	2825	3125	3725
Height H (unsupported)	2875	3175	3675	4275	5475

#### Chain length:

$$L_k \approx \frac{L_s}{2} + L_B$$

rounded to chain pitch

#### Installation height\*:

$$H_z = H + z$$

Pre-tension  $z \approx 10$  mm/m chain length

\* required clear height

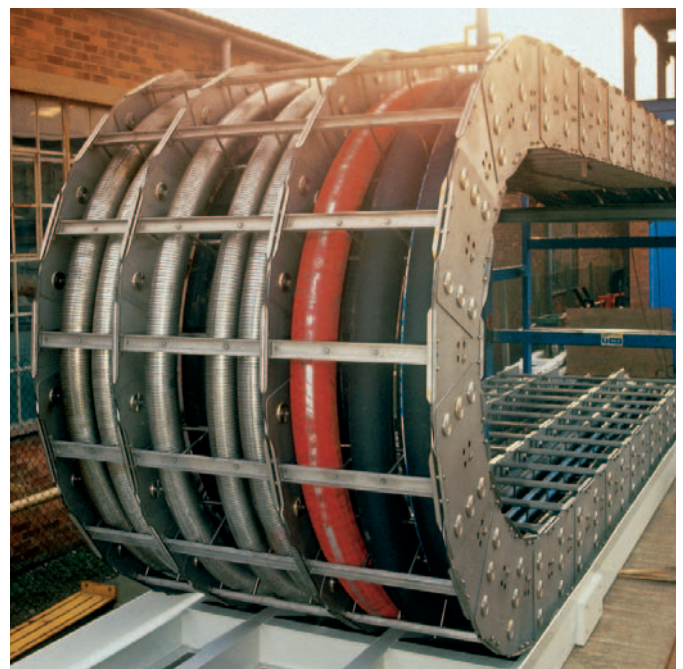

## Type S/SX 5000 / 6000 / 7000

### Load diagramm

**Unsupported length  $L_f$  and travel length  $L_s$  without support** depending on the additional load (see design guidelines).

The intrinsic chain weight has been based on the weight of the chain bands for the load diagram.

- 40 kg/m** for Type **S/SX 5000**
- 50 kg/m** for Type **S/SX 6000**
- 125 kg/m** for Type **S/SX 7000**

The permitted additional load is reduced by the difference for a larger intrinsic weight.

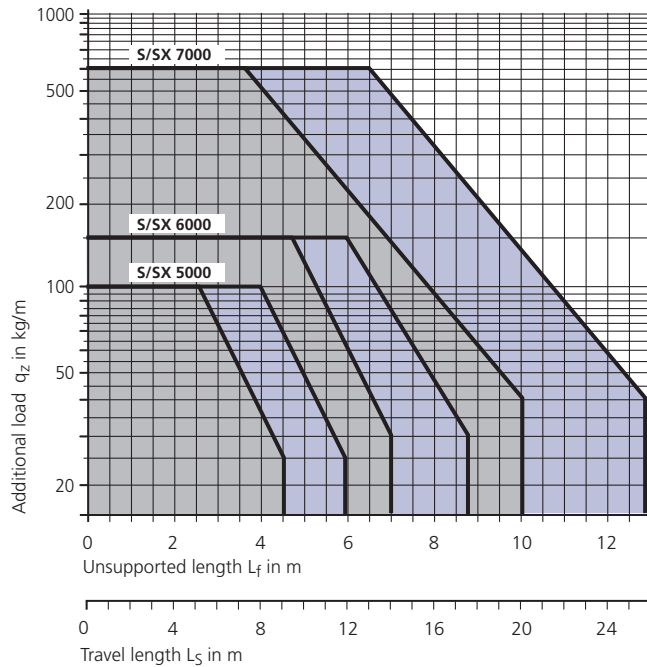

- S 5000/6000/7000 material Steel
- SX 5000/6000/7000 material ER 2
- SX 5000/6000/7000 material ER 1

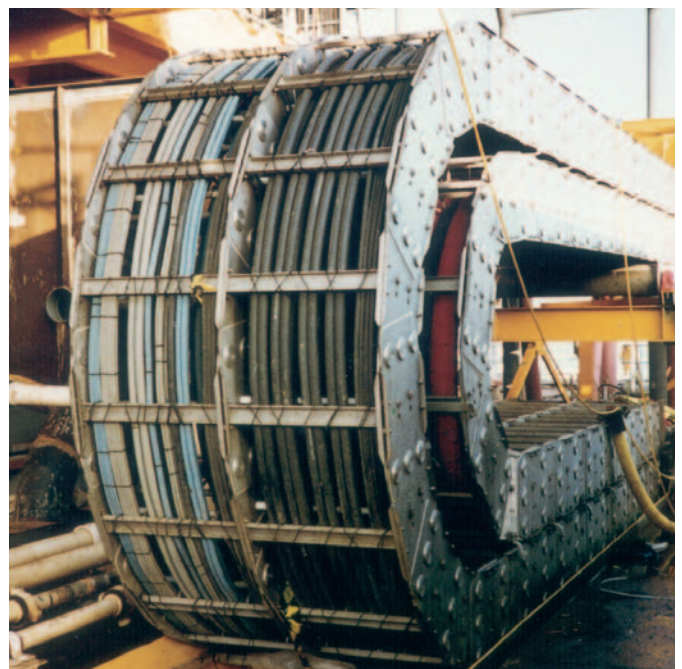

# Type S/SX 5000 / 6000 / 7000

## Chain cross section

### Chain and stay width

Dimensions in mm

Type	Chain width	Stay width $B_{St}$	$h_i$ max
S/SX 5000	$B_i + 117$	$B_i + 38$	150
S/SX 6000	$B_i + 123$	$B_i + 38$	240
S/SX 7000	$B_i + 150$	$B_i + 60$	370

Type	$B_k$ min	$B_k$ max	$s_T$	$a_T$ max	$a_x$ max
S/SX 5000	250	1200	10	150	150
S/SX 6000	300	1500	10	200	200
S/SX 7000	350	1800	10	250	250

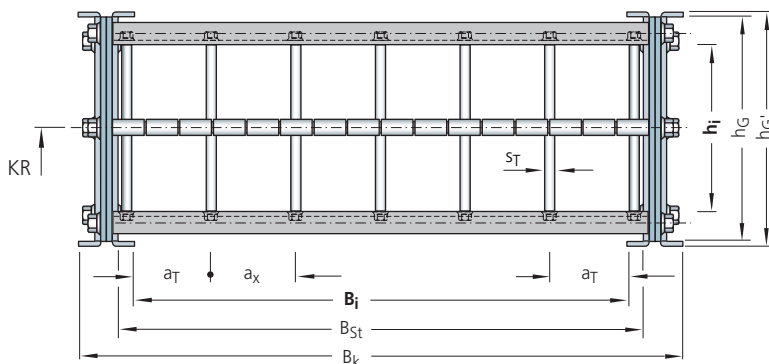

All chain cross sections according to sectional information in the schematic illustration.

## Intrinsic chain weight

### for two band chains

depending on the chain width.

Weight of the chain bands (excluding stays):

- 40 kg/m for Type S/SX 5000
- 50 kg/m for Type S/SX 6000
- 125 kg/m for Type S/SX 7000

- Type S/SX 5000
- Type S/SX 6000
- Type S/SX 7000

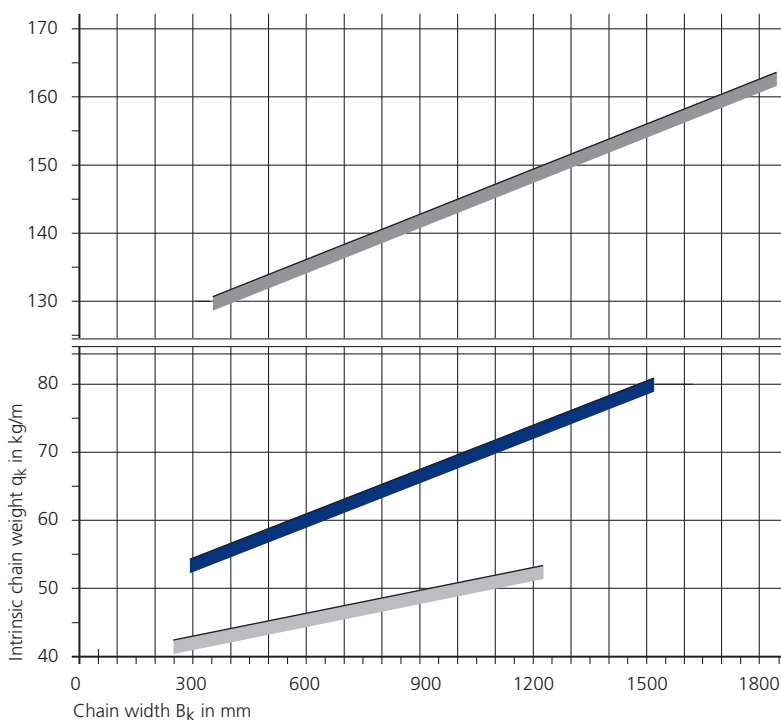

## Design and ordering

Please contact us, we would be happy to advise you.

Guide channels  
➤ from page 166

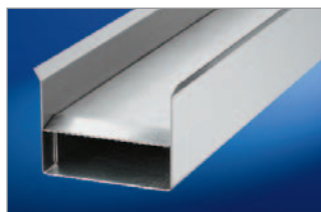

Strain relief devices  
➤ from page 173



Cables for cable carrier systems  
➤ in our TRAXLINE Cables for Motion catalogue.



### Type S/SX 5000 / 6000 / 7000

#### Fixed point connection

##### Connection variant FA

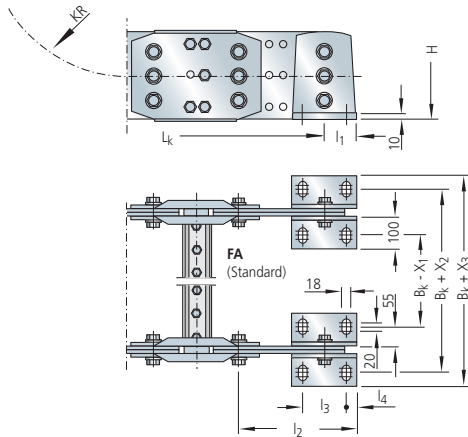

##### Connection variant FI

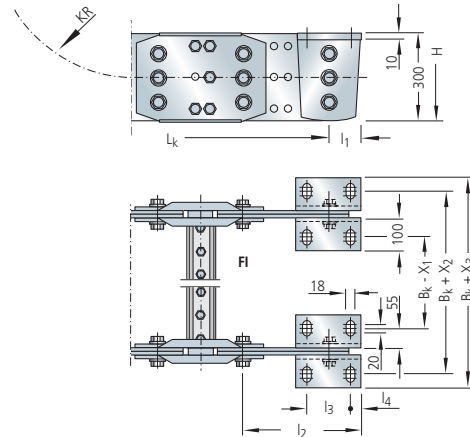

LS/LSX Series

S/SX 5000 – 7000

#### Driver connection

##### Connection variant MA

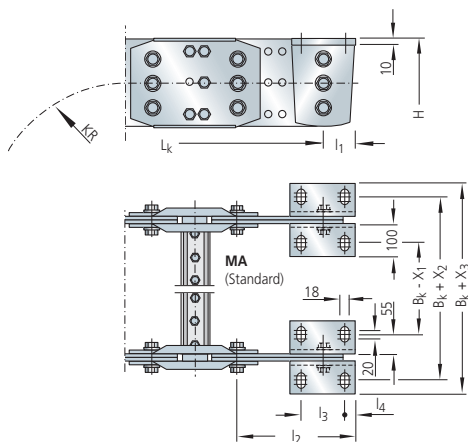

##### Connection variant MI

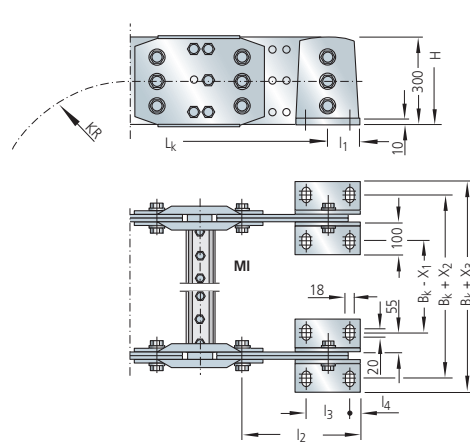

CONDUFLEX  
MOBIFLEX

TRAXLINE  
TOTALTRAX

Type	S/SX 5000	S/SX 6000	S/SX 7000
l <sub>1</sub>	75	125	200
l <sub>2</sub>	275	445	650
l <sub>3</sub>	100	200	230
l <sub>4</sub>	25	25	25
X <sub>1</sub>	189	195	200
X <sub>2</sub>	44	38	38
X <sub>3</sub>	134	128	128

Driver and fixed point connection using double end connectors on the inside link plates.

Different connection variants for fixed point and driver are possible according to the drawing information and are realized by different assembly of the connecting pieces. The connection variants can also be changed at a later date if required.

Accessories

Application  
Examples





## Flexible energy conduits – TUBES

# CONDUFLEX

Closed designer cable carrier.



Type	Height $h_i$	Clear width $B_i$
CF 055	25	45
CF 060	40	36
CF 085	38	73
CF 115	52	102
CF 120	70	100
CF 175	72	162

2D/3D-Data  
kabelschlepp.de/cad-gb

- enclosed cable carriers in a sophisticated design
- attractive appearance due to stainless steel crossbars and frame made of fiberglass reinforced polyamide
- easy replacement of the crossbars where external damage has occurred
- optimized protection for cables and hoses
- subsequent shortening or lengthening is possible easily
- TÜV type tested according to 2 PfG 1036/10.97

# MOBIFLEX

Enclosed cable carriers with flexible metal helical tube.

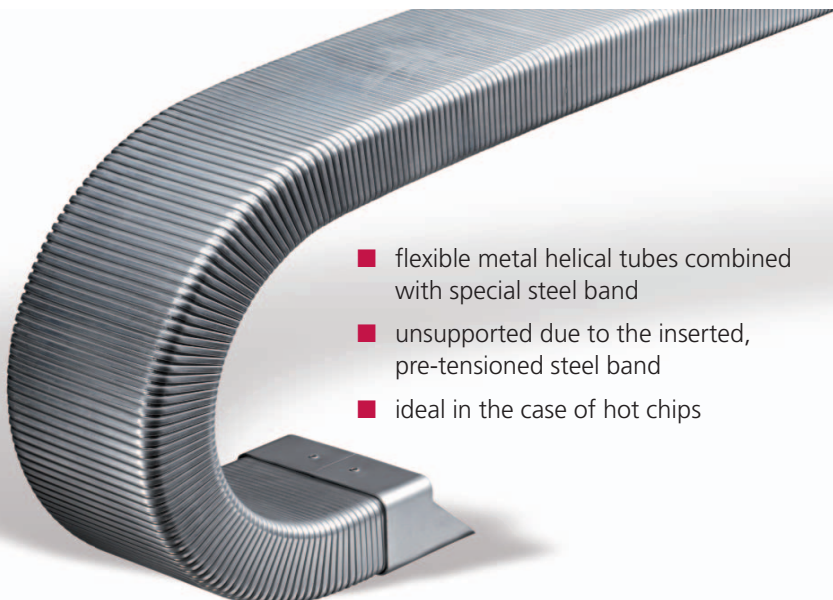

Type	Height $h_i$	Clear width $B_i$
MF 030.1	24	26
MF 050.1	24	45
MF 050.2	44	45
MF 080.1	40	80
MF 080.2	54	80
MF 080.3	78	80
MF 110.1	53	109
MF 110.2	73	109
MF 110.3	108	109
MF 170.1	72	170
MF 170.2	102	170
MF 170.3	167	170

- flexible metal helical tubes combined with special steel band
- unsupported due to the inserted, pre-tensioned steel band
- ideal in the case of hot chips

# Flexible energy conduits CONDUFLEX

## Rolling schematic illustration unsupported arrangement

- Chain pitch  $t$  = type-dependent, see dimensions table on page 151
- Height  $h_G$  = see hose cross sections on page 151
- Connection height  $H = 2 KR + h_G$  (unsupported)
- Connection length  $l_1$  = see connection dimensions

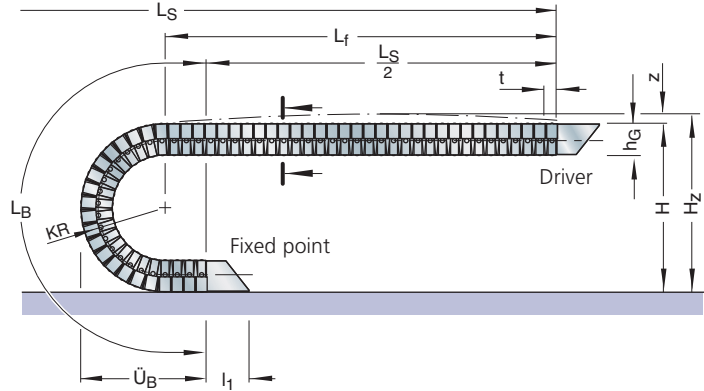

A flat and level surface is required for the flexible conduit to be installed properly. If necessary a support tray should be used (see page 169).

### Variable sizes

depending on the bend radius

Dimensions in mm

CONDUFLEX Type	KR	L <sub>B</sub>	Ü <sub>B</sub>	H <sub>min</sub>	Conduit weight in kg/m
CF 055	65	405	184	168	1.25
	100	515	219	238	
	150	675	269	338	
CF 060	100	515	226	252	1.60
CF 085	100	515	226	252	1.90
	150	675	276	353	
	200	830	326	452	
	250	985	376	552	
CF 115	140	690	299	347	2.60
	225	960	384	517	
	300	1200	459	667	
CF 120	155	740	323	396	3.80
	200	880	368	486	
CF 175	185	830	382	464	5.20
	250	1035	447	594	
	350	1400	547	794	

- KR = Bend radius
- L<sub>B</sub> = Length of bend
- Ü<sub>B</sub> = Bend overhang
- H<sub>min</sub> = Minimum connection height

**Length of conduit:**

$$L_{ES} \approx \frac{L_S}{2} + L_B$$

rounded to pitch  $t$

## Load diagramm

Unsupported length  $L_f$  and travel length  $L_s$  without support depending on the additional load (see design guidelines).

### Long travel lengths

If the unsupported length of the flexible conduit is exceeded, it may be possible to cover the required travel length with the assistance of suitable supports. Please contact us.

Design: see Construction Guidelines.

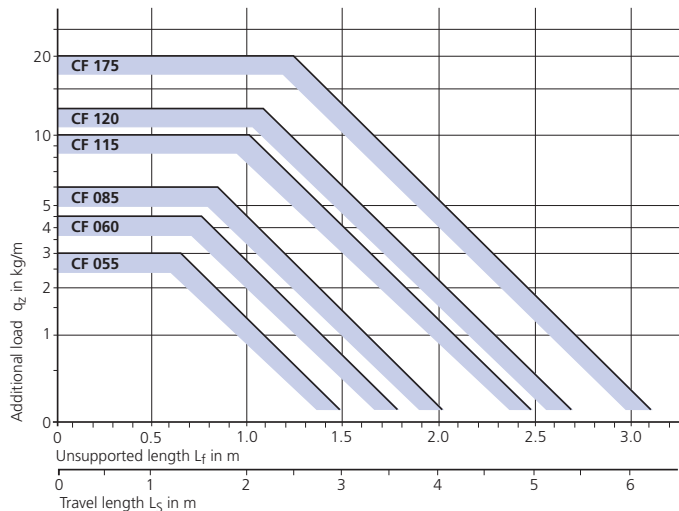

## Flexible energy conduits CONDUFLEX

Cross section according to sectional information in the schematic illustration

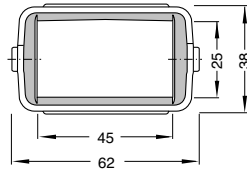
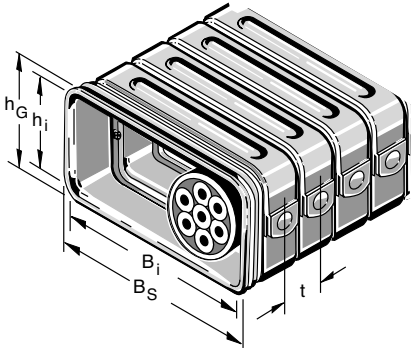

CONDUFLEX  
Type CF 055\*

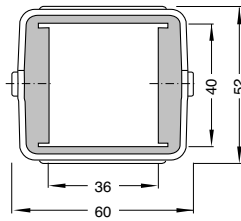

CONDUFLEX  
Type CF 060

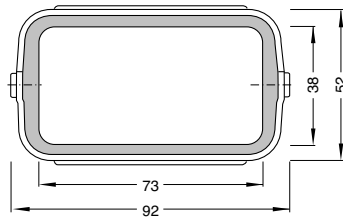

CONDUFLEX  
Type CF 085\*

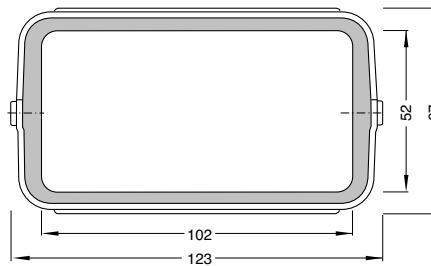

CONDUFLEX  
Type CF 115\*

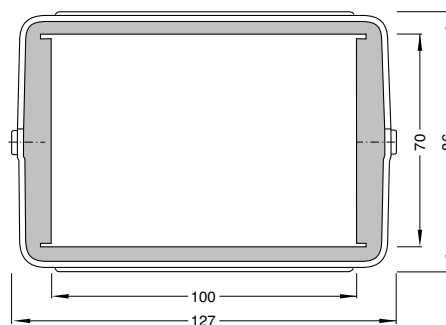

CONDUFLEX  
Type CF 120

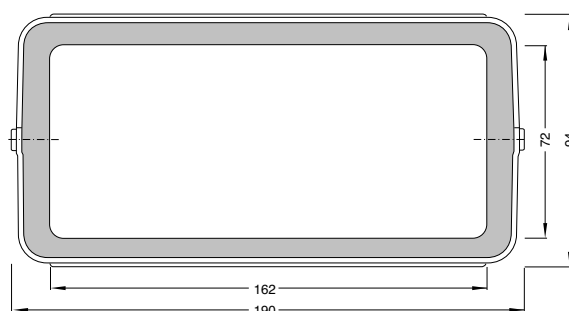

CONDUFLEX  
Type CF 175\*

### Dimensions

Dimensions in mm

CONDUFLEX Type	B <sub>s</sub>	B <sub>i</sub>	h <sub>G</sub>	h <sub>i</sub>	t
CF 055*	62	45	38	25	20
CF 060	60	36	52	40	20
CF 085*	92	73	52	38	20
CF 115*	123	102	67	52	25
CF 120	127	100	86	70	25
CF 175*	190	162	94	72	30

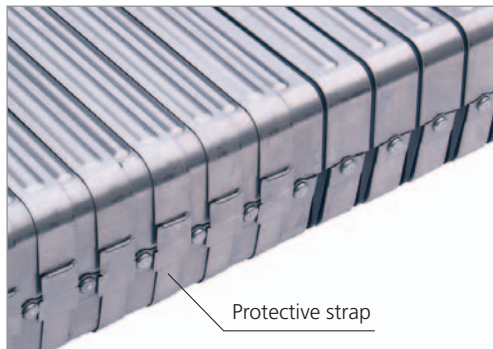

Protective strap

\*) CONDUFLEX flexible energy conduits types CF 055, CF 085, CF 115 und CF 175 can be fitted with protective straps to shield the impact slots of the plastic frames from contamination.

The "Guidelines for Installing Cables and Hoses in Cable Carriers" are to be observed when planning a CONDUFLEX flexible energy conduit (see Construction Guidelines)!

# Flexible energy conduits CONDUFLEX

## Connection dimensions

### Diagonal flange connector bracket – SF

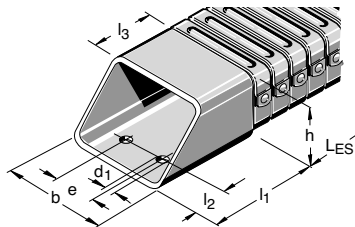

Dimensions in mm

CONDUFLEX Type	b	h	e	d <sub>1</sub>	l <sub>1</sub>	l <sub>2</sub>	l <sub>3</sub>
CF 055	55	36	22	6.5	44	12.5	20
CF 060	55	52	22	6.5	44	12.5	20
CF 085	85	50	50	6.5	70	15.0	32
CF 115	117	66	70	8.5	84	17.5	34
CF 120	120	84	70	8.5	82	17.5	38
CF 175	182	92	100	10.5	100	22.5	45

#### Connector variants for diagonal flange connectors SF

Connecting surfaces outside/outside



1

Connecting surfaces inside/outside



2

Connecting surfaces inside/inside

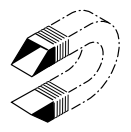

3

Please state the position of the connecting surfaces when ordering.

### Standard connector bracket – ST

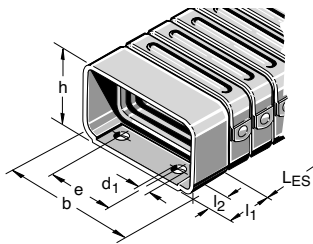

Dimensions in mm

CONDUFLEX Type	b	h	e	d <sub>1</sub>	l <sub>1</sub>	l <sub>2</sub>
CF 055	55	36	22	6.5	20	8.5
CF 060	–	–	–	–	–	–
CF 085	85	52	50	6.5	25	10.0
CF 115	116	68	65-70	8.5	35	10.0
CF 120	120	84	70	8.5	35	12.5
CF 175	182	92	100	10.5	40	15.0

#### Connector variants for standard connectors ST

Connecting surfaces outside/outside



1

Connecting surfaces inside/outside



2

Connecting surfaces inside/inside

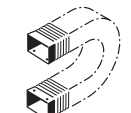

3

Please state the position of the connecting surfaces when ordering.

### Cross flange connector bracket – QF

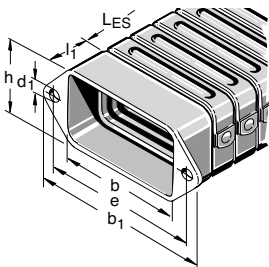

Dimensions in mm

CONDUFLEX Type	b	h	b <sub>1</sub>	e	d <sub>1</sub>	l <sub>1</sub>
CF 055	55	35	90	75	6.5	20
CF 060	–	–	–	–	–	–
CF 085	85	50	120	105	6.5	25
CF 115	116	64	160	140	8.5	35
CF 120	–	–	–	–	–	–
CF 175	182	90	226	200	10.5	40

### High flange connector bracket – HF

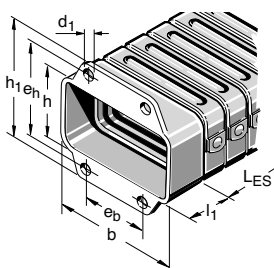

Dimensions in mm

CONDUFLEX Type	b	h	h <sub>1</sub>	e <sub>b</sub>	e <sub>h</sub>	d <sub>1</sub>	l <sub>1</sub>
CF 055	55	35	70	18	55	6.5	20
CF 060	–	–	–	–	–	–	–
CF 085	85	50	85	45	70	6.5	25
CF 115	116	64	110	60	90	8.5	35
CF 120	–	–	–	–	–	–	–
CF 175	182	90	136	95	110	10.5	40

The connectors SF, ST, QF and HF can be combined. Please state when ordering.

## Flexible energy conduits CONDUFLEX

### Ordering – cable carrier

Cable Carrier		
<b>CF 115</b>	<b>140</b>	<b>1200</b>
CONDUFLEX Type	Bend radius KR in mm	Length of conduit L <sub>ES</sub> in mm (without connection)

### Ordering – connection

Connection			
<b>F</b>	<b>QF</b>	<b>M</b>	<b>HF</b>
Fixed point	Connection type	Driver	Connection type

#### Connector variants for diagonal flange connectors SF



#### Connector variants for standard connectors ST

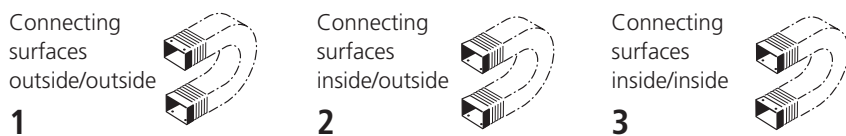

Please state the position of the connecting surfaces for connection variants SF and ST when ordering.

Guide channels  
➤ from page 166

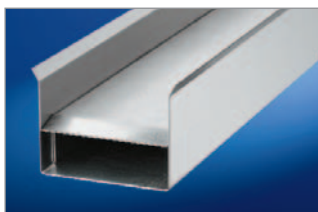

Strain relief devices  
➤ from page 173



Cables for cable carrier systems  
➤ in our TRAXLINE Cables for Motion catalogue.



# Flexible energy conduits MOBIFLEX

## Rolling schematic illustration unsupported arrangement

- Height  $h_G$  = see hose cross sections
- Connection height  $H = 2 KR + h_G$  (unsupported)
- Required clearance height  $H_z = H + z$  ( $z \approx 50$  mm)
- Bend overhang  $\ddot{U}_B = 1.5 KR + h_G/2$

A flat and level surface is required for the flexible conduit to be installed properly. If necessary a support tray should be used (see page 169).

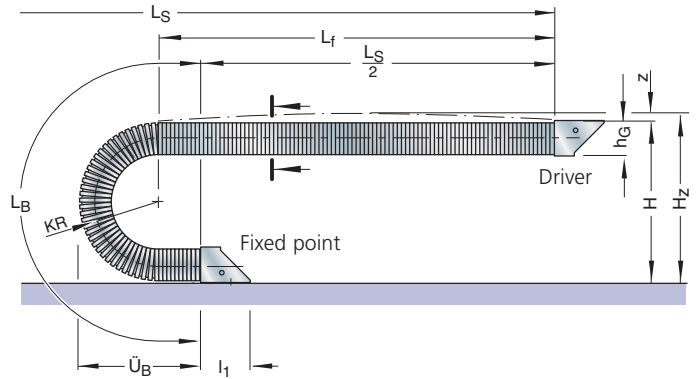

## Dimensions / Weights

Dimensions in mm/Weights in kg/m

MOBIFLEX Type	B <sub>S</sub>	B <sub>i</sub>	h <sub>G</sub>	h <sub>i</sub>	Available bend radii KR	Weight G <sub>S</sub>	Contraction L <sub>VK</sub>
MF 030.1	30	26	30	24	80	–	45
MF 050.1	50	45	30	24	75	100	45
MF 050.2	50	45	50	44	110	150	80
MF 080.1	85	80	45	40	100	150	70
MF 080.2	85	80	60	54	150	200	95
MF 080.3	85	80	85	78	200	–	135
MF 110.1	115	109	60	53	150	200	95
MF 110.2	115	109	80	73	200	250	125
MF 110.3	115	109	115	108	300	–	180
MF 170.1	175	170	80	72	190	250 300 350	125
MF 170.2	175	170	110	102	250	300	175
MF 170.3	175	170	175	167	365	–	275

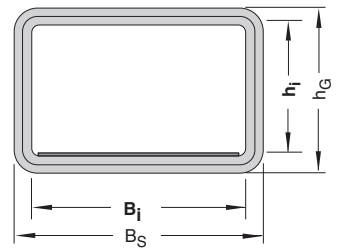

### Length of conduit (with loop):

$$L_{ES} \approx \frac{L_S}{2} + L_B$$

Bend length  
 $L_B = KR \cdot \pi + \text{Reserve (KR)}$

### Stretched length of conduit:

$$L_{\text{stretched}} = L_{ES} - L_{VK}$$

Shortening of conduit  
 $L_{VK} = h_G/2 \cdot \pi$

Specified bend radii =  $KR_{\text{max}}$   
 Production-related tolerances: -20 to -30 mm

## Load diagramm

Unsupported length  $L_f$  and travel length  $L_s$  without support depending on the additional load (see design guidelines).

### Long travel lengths

If the unsupported length of the flexible conduit is exceeded, it may be possible to cover the required travel length with the assistance of suitable supports. Please contact us.

Design: see Construction Guidelines.

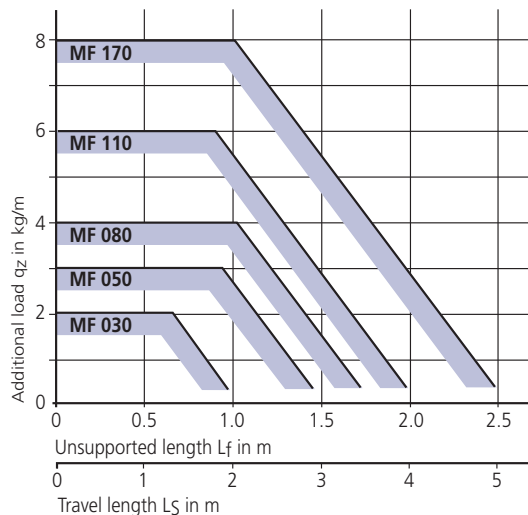

# Flexible energy conduits MOBIFLEX

## Connection Dimensions

### Diagonal flange connector bracket – SF

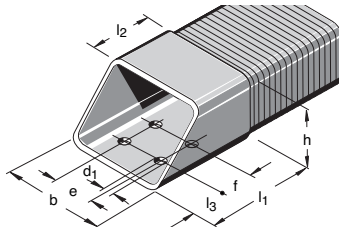

Dimensions in mm

Type	b	h	e	f	d	l <sub>1</sub>	l <sub>2</sub>	l <sub>3</sub>
MF 030.1	34	34	–	40	9	120	60	10
MF 050.1	54	34	20	40	9	120	60	10
MF 050.2	54	54	20	40	9	120	60	10
MF 080.1	90	50	50	40	9	120	60	10
MF 080.2	90	65	50	40	9	120	60	10
MF 080.3	90	90	50	40	9	120	60	10
MF 110.1	120	65	80	40	9	120	60	10
MF 110.2	120	85	80	40	9	120	60	10
MF 110.3	120	120	80	40	9	120	60	10
MF 170.1	180	85	140	40	9	120	60	10
MF 170.2	180	115	140	40	9	120	60	10
MF 170.3	180	180	140	40	9	120	60	10

LS/LSX Series

S/SX Series

### Connector variants for diagonal flange connectors SF

Connecting surfaces outside/outside  
**1**



Connecting surfaces inside/outside  
**2**



Connecting surfaces inside/inside  
**3**

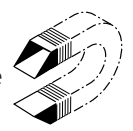

Please state the position of the connecting surfaces when ordering.

Dimensions in mm

### Standard connector bracket – ST

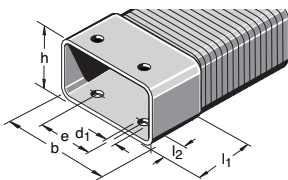

### Cross flange connector bracket – QF

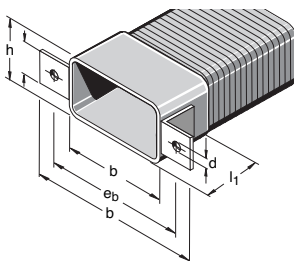

### High flange connector bracket – HF

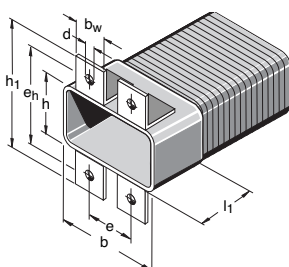

Type	b	h	e	e <sub>b</sub>	e <sub>h</sub>	d	l <sub>1</sub>	l <sub>2</sub>	b <sub>w</sub>	b <sub>1</sub>	h <sub>1</sub>
MF 030.1	34	34	–	56	56	9	60	20	20	74	74
MF 050.1	54	34	20	76	56	9	60	20	20	94	74
MF 050.2	54	54	20	76	76	9	60	20	20	94	94
MF 080.1	89	49	50	111	71	9	75	20	20	129	89
MF 080.2	89	64	50	111	86	9	75	20	20	129	104
MF 080.3	89	89	50	111	111	9	75	20	20	129	129
MF 110.1	119	64	80	141	86	9	95	20	20	159	104
MF 110.2	119	84	80	141	106	9	95	20	20	159	124
MF 110.3	119	119	80	141	141	9	95	20	20	159	159
MF 170.1	179	84	140	201	106	9	95	20	20	219	124
MF 170.2	179	114	140	201	136	9	95	20	20	219	154
MF 170.3	179	179	140	201	201	9	95	20	20	219	219

Front flange connectors can be supplied in accordance with customer drawings.

CONDUFLEX  
MOBIFLEX

TRAXLINE  
TOTALTRAX

Accessories

Application  
Examples

The connectors SF, ST, QF and HF can be combined. Please state when ordering.

# Flexible energy conduits MOBIFLEX

## Ordering – cable carrier

Cable Carrier		
<b>MF 170.2</b>	<b>300</b>	<b>1800</b>
MOBIFLEX Type	Bend radius KR in mm	Length of conduit L <sub>ES</sub> in mm (without connection)

## Ordering – connection

Connection			
<b>F</b>	<b>QF</b>	<b>M</b>	<b>HF</b>
Fixed point	Connection type	Driver	Connection type

### Connector variants for diagonal flange connectors SF

Connecting surfaces outside/outside



**1**

Connecting surfaces inside/outside



**2**

Connecting surfaces inside/inside

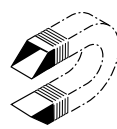

**3**

Please state the position of the connecting surfaces for connection variant SF when ordering.

Guide channels  
 ➤ from page 166

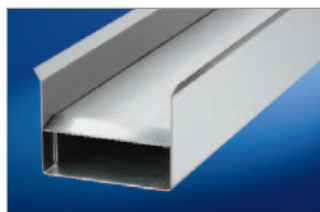

Strain relief devices  
 ➤ from page 173



Cables for cable carrier systems  
 ➤ in our TRAXLINE Cables for Motion catalogue.





Electrical cables for cable carriers

# TRAXLINE Cables for Motion

Continuous bending hi-flex electrical cables for cable carriers



TSUBAKI KABELSCHLEPP  
TRAXLINE  
cables for  
cable carriers

LS/LSX Series

S/SX Series

CONDUFLEX  
MOBIFLEX

Fully harnessed cable carrier systems

# TOTALTRAX

Cable carrier, cable and connector – ready to connect

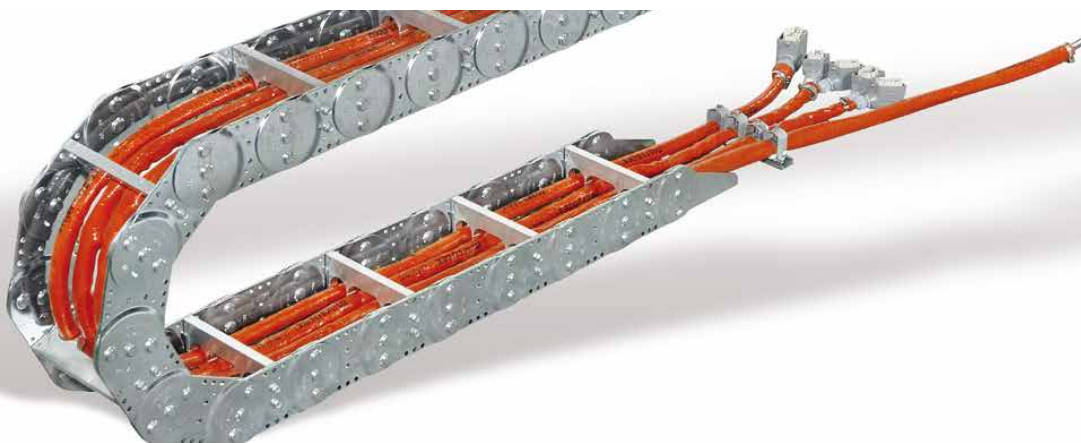

TRAXLINE  
TOTALTRAX

Accessories

Application  
Examples

# Cost-effective – safe – reliable.

## TRAXLINE cables for cable carriers

TSUBAKI KABELSCHLEPP – the inventor of the cable carrier. Our product portfolio covers more than 100,000 variants made of steel and plastic, allowing us to deliver a suitable and reliable cable carrier for every application – from standard off-the-shelf products to custom-designed complete solutions. Wherever you are in the world, we are here to help. We use our over 50 years of experience to continuously develop and refine the “insides” – i.e. the TRAXLINE cables – and to constantly adapt them to the market requirements.

Our cable ranges meet the highest quality standards in order to ensure availability of your systems and installations.

With the TRAXLINE range, we offer a selection of cables which are cost-effective, flexible and extremely durable.

A key factor for our cables is their tested and proven operational reliability, which meets all applicable standards and directives.

Competent, objective-driven systems consultation and global on-site service are both part of what we consider an on-going commitment to the technical and commercial optimisation of your applications.

### TRAXLINE cable types

- Control cables
- Power cables
- Data cables
- BUS-/FOC-/Coaxial cables
- System cables
- Power One Heavy Duty
- TRAXLINE harnessed:
  - USB / CAT5E / CAT6
  - Signal cables
  - Power cables



TSUBAKI KABELSCHLEPP  
TRAXLINE  
cables for  
cable carriers

■ Pre-assembled TRAXLINE electrical cables in a steel cable carrier S 0950

## Design features which give you reliability.

- Outer jacket made of highly flexible and resistant special compounds
- Maximum stability and service life due to valley-sealed filling extrusion technology (type-dependent)
- Requirements-optimized cabling (layer cabling, low torsion in short pitches / bundled stranding / hybrid layouts)
- Valley-sealed extruded inner jacket (type-dependent)
- Flexible shielding with outstanding electrical properties for shielded types
- Use of high quality and application-optimized core elements
- Small bend radii for compact cable carriers
- cURus approval
- DESINA jacket colors (type-dependent)

## TSUBAKI KABELSCHLEPP and EPLAN

EPLAN has developed over more than 20 years into a leading E-CAD system and has become more-or-less established as a standard in some branches.

### TRAXLINE cable database for EPLAN

As a provider of highly-flexible electrical cables for cable and hose carriers, we offer you the TSUBAKI KABELSCHLEPP TRAXLINE cable data bases as a superior tool for optimising your daily work with EPLAN.

The databases are optimized for use in EPLAN5 and for transmission according to EPLAN P8 electric.

- easy cable selection by construction
- automatic addition of core number, cross-section and core colour
- complete data for parts lists and other evaluations

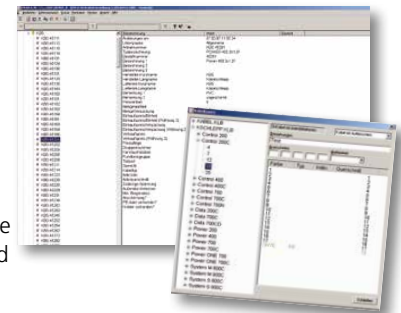

## TSUBAKI KABELSCHLEPP cable warehouse

Hundreds of cable types, stored constantly in our cable warehouse, secure a fast availability all around the world. We deliver according to your requirements, no minimum quantities, each length without extra cutting costs.



■ TSUBAKI KABELSCHLEPP cable warehouse

## Large selection of types – available directly from stock.



You will find cables for different application areas with a large choice of various cross sections in our cable range – directly available from stock.



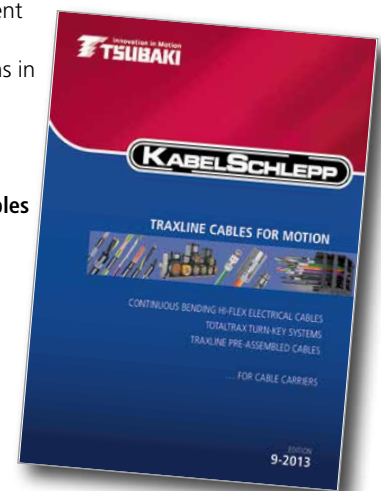







The complete cable range can be found in our TRAXLINE Cables for Motion catalogue. Please request a copy.

More information:  
[kabelschlepp.de/traxline-gb](http://kabelschlepp.de/traxline-gb)

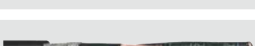

## Overview TRAXLINE cable types

Cable type		Outer jacket	Shield	Factor for $KR_{min} = n \times \varnothing$ cable	Temperature moved	Approvals	Standards	Colour type-dependent	Halogen-free	Flame-retardant	Oil-resistant	$V_{max}$ supported (m/s)	$V_{max}$ gliding (m/s)	$a_{max}$ (m/s <sup>2</sup> )	Diameter mm <sup>2</sup> /Type/Other	Core number
<b>CONTROL cables</b>																
CONTROL 200		PVC	—	10	-5 to +80 °C	 		black	—	✓	✓	3.5	2	10	0.5 <sup>2</sup> to 2.5 <sup>2</sup>	2-25
CONTROL 200 C		PVC	✓	10	-5 to +80 °C	 		black	—	✓	✓	3.5	2	10	0.5 <sup>2</sup> to 1.5 <sup>2</sup>	2-25
CONTROL 400 600 V		PVC	—	7.5	-5 to +80 °C	 		black	—	✓	✓	5	3	20	0.34 <sup>2</sup> to 2.5 <sup>2</sup>	2-48
CONTROL 400 C 600 V		PVC	✓	7.5	-5 to +80 °C	 		black	—	✓	✓	5	3	20	0.5 <sup>2</sup> to 1.5 <sup>2</sup>	3-36
CONTROL 700 600 V		PUR	—	7.5	-35 to +90 °C	 		black	✓	✓	✓	20	5	50	0.5 <sup>2</sup> to 1 <sup>2</sup>	2-36
CONTROL 700 C 600 V		PUR	✓	7.5	-35 to +90 °C	 		black	✓	✓	✓	20	5	50	0.5 <sup>2</sup> to 1 <sup>2</sup>	3-25
<b>POWER cables</b>																
POWER 400 1 kV		PVC	—	7.5	-5 to +80 °C	 		black	—	✓	✓	5	3	20	1.5 <sup>2</sup> to 70 <sup>2</sup>	2-25
POWER 400 C 1 kV		PVC	✓	7.5	-5 to +80 °C	 		black	—	✓	✓	5	3	20	1.5 <sup>2</sup> to 35 <sup>2</sup>	4-7
POWER 700 1 kV		PUR	—	7.5	-35 to +90 °C	 		black	✓	✓	✓	20	5	50	1.5 <sup>2</sup> to 95 <sup>2</sup>	2-36
POWER ONE 700 1 kV		PUR	—	7.5	-35 to +90 °C	 		black	✓	✓	✓	20	5	50	0.25 <sup>2</sup> to 700 <sup>2</sup>	1
POWER ONE 700 PE		PUR	—	7.5	-35 to +90 °C	 		black	✓	✓	✓	20	5	50	1.5 <sup>2</sup> to 95 <sup>2</sup>	1
POWER 700 C 1 kV		PUR	✓	7.5	-35 to +90 °C	 		black	✓	✓	✓	20	5	50	1.5 <sup>2</sup> to 150 <sup>2</sup>	2-49
POWER ONE 700 C 1 kV		PUR	✓	7.5	-35 to +90 °C	 		black	✓	✓	✓	20	5	50	1.5 <sup>2</sup> to 300 <sup>2</sup>	1
<b>DATA cables</b>																
DATA 400 C		PVC	✓	7.5	-5 to +80 °C	 		black	—	✓	✓	5	3	20	0.25 <sup>2</sup> to 0.34 <sup>2</sup>	4-25
DATA 700		PUR	—	7.5	-35 to +90 °C	 		black	✓	✓	✓	20	5	50	0.25 <sup>2</sup> to 0.34 <sup>2</sup>	3-15
DATA 700 TPI C		PUR	✓	7.5	-35 to +90 °C	 		black	✓	✓	✓	20	5	50	0.25 <sup>2</sup> to 1 <sup>2</sup>	2-32
DATA 700 TPI CD / POWER 700 TPI CD 1 kV		PUR	✓	7.5	-35 to +90 °C	 		black	✓	✓	✓	20	5	50	0.25 <sup>2</sup> to 1.5 <sup>2</sup>	6-20

Cable type		Outer jacket	Shield	Factor for KR <sub>min</sub> = n x Ø cable	Temperature moved	Approvals	Standards	Colour type-dependent	Halogen-free	Flame-retardant	Oil-resistant	v <sub>max</sub> supported (m/s)	v <sub>max</sub> gliding (m/s)	a <sub>max</sub> (m/s <sup>2</sup> )	Diameter mm <sup>2</sup> / Type/Other	Core number
<b>BUS-/fiber optic-/coaxial cables</b>																
PROFIBUS 700 C		PUR	✓	15	-20 to +70 °C	cRU US	CE RoHS conform	purple	✓	✓	✓	3.5	2	10	0.64 mm	2
CAN-BUS 700 C		PUR	✓	7.5	-20 to +80 °C	cRU US	CE RoHS conform	black	✓	✓	✓	3	3	10	0.5 <sup>2</sup>	2-4
USB S 700 C / USB L 700 C		PUR	✓	10	-10 to +70 °C	cRU US	CE RoHS conform	purple	✓	✓	✓	3.5	2	10	AWG 28 / 24 / 20	4
INTERBUS 700 C		PUR	✓	10	-30 to +70 °C	cRU US	CE RoHS conform	purple	✓	✓	✓	3.5	2	10	0.25 <sup>2</sup>	6
CAT.5E / CAT.6 700 CD		PUR	✓	10	-30 to +80 °C	cRU US	CE RoHS conform	green	✓	✓	✓	3	3	5	0.15 <sup>2</sup>	8
KOAX 700 CD		PUR	✓	10	-20 to +70 °C		CE RoHS conform	black	✓	✓	✓	3.5	3.5	10	HF 50/75 Ω	1- 5
FOC 700		PUR	-	7.5	-30 to +90 °C		CE RoHS conform	black	✓	✓	-	3.5	3.5	10	50µ/ 62.5µ	6- 12
<b>OEM SYSTEM cables</b>																
SYSTEM S 700 C		PUR	✓	7.5	-35 to +90 °C	cRU US	CE RoHS conform	green	✓	✓	✓	5	5	50	0.14 <sup>2</sup> to 0.1 <sup>2</sup>	3- 16
SYSTEM M 700 C		PUR	✓	7.5	-35 to +90 °C	cRU US	CE RoHS conform	orange	✓	✓	✓	5	5	50	1 <sup>2</sup> to 50 <sup>2</sup>	4
<b>Power One Heavy Duty High voltage cable</b>																
POWER ONE HEAVY DUTY 10 kV / 11 kV / 12 kV		PUR	✓	7.5	-40 to +80 °C		CE RoHS conform	red	✓	✓	✓	50	10, 6	50	10 <sup>2</sup> to 400 <sup>2</sup>	1
POWER ONE HEAVY DUTY 15 kV / 24 kV / 30 kV		PUR	✓	7.5	-40 to +80 °C		CE RoHS conform	red	✓	✓	✓	50	10, 6	50	10 <sup>2</sup> to 400 <sup>2</sup>	1

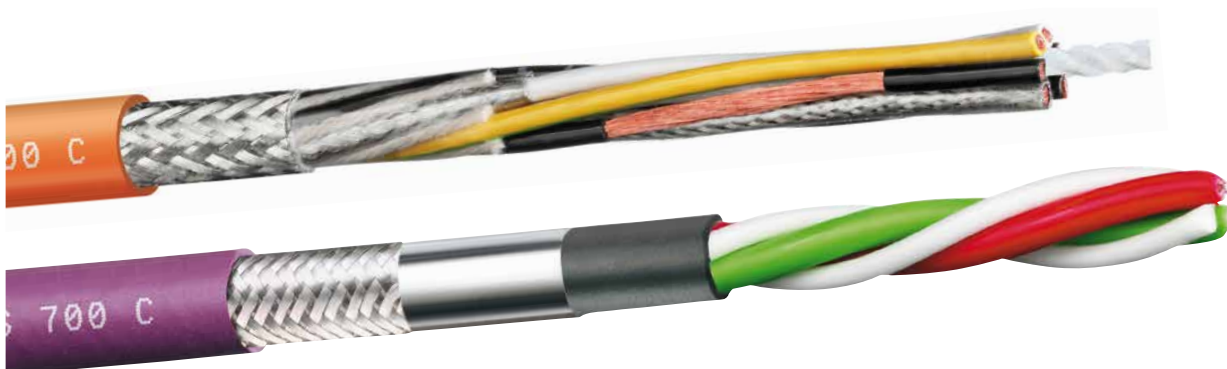

# TOTALTRAX turn-key systems.

Fully harnessed cable carrier systems.

You know what product you need – we supply it to you completely harnessed.

## One supplier and contact person for the complete system

We develop, design and supply all components required for your individual cable & hose carrier system.



■ Ready-to-connect assembled plastic cable carrier system, packed ready for installation

## Everything from a single source

- Consulting
- Planning
- Design
- Cable carriers
- Electrical cables
- Complete guarantee

- Hydraulic hoses
- Pneumatic hoses
- Plug-and-socket connectors
- Assembly plates
- Complete assembly of all components

- + One contact person
- + One order
- + One delivery
- + Guaranteed quality

= **TOTALTRAX Complete System**

## TOTALTRAX – from design to the complete system



### NOTE:

#### Harnessed cables according to all OEM

We manufacture TSUBAKI KABELSCHLEPP TRAXLINE cables according to OEM specifications, suitable for all drive controls which consist of signal and power cables and/or extension cables.

- any cable length available
- delivery minimum: 1 unit

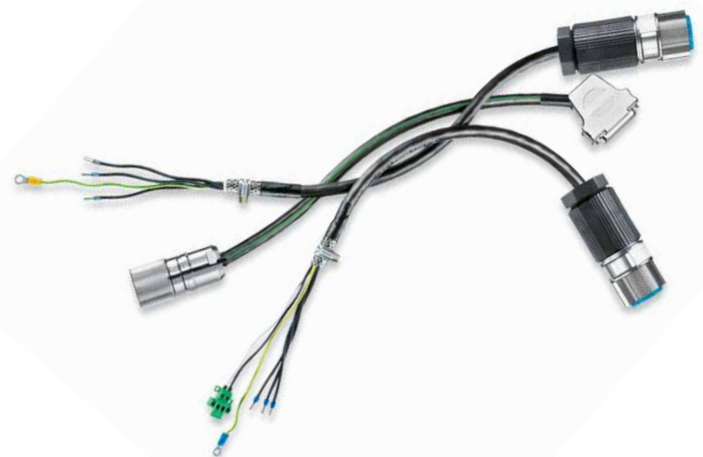

## Cut costs with TOTALTRAX complete cable carrier systems

We help you . . .

- Advice on planning
- Support in the design phase
- Only one contact person for the complete system including all the individual components
- Complete delivery from a single source
- Only one supplier – one purchase order and one item number
- All components match each other perfectly
- Guarantee certificate upon requests

. . . to cut your costs!

- Goods receiving inspections for all individual components are no longer required
- Expensive technical personnel and special tools are no longer required
- Shorter assembly times
- No hidden costs, e.g. cables being cut to excessive lengths etc.
- Less captive capital with almost no inventory
- On-time delivery directly to your production site

## No storage costs for individual components

Our warehouses offer cables, plug-and-socket connectors as well as many other individual components.



■ Complete system with reusable shipping fixture

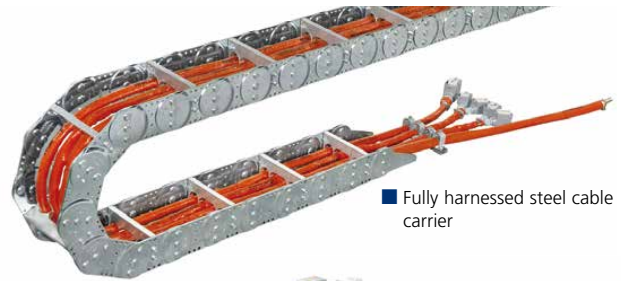

■ Fully harnessed steel cable carrier



■ Plastic cable carrier fully harnessed with cables, hoses, connectors and holding plates

## Complete service – even for applications with extreme assembly conditions

Our service team can design and assemble your cable carrier system even for applications with extreme assembly conditions.

Our service center experts provide you with the support you need.

- Complete assembly with guide channels
- Uncoiling of harnessed cable carrier systems with long travel lengths
- Assembly at great heights (e. g. crane systems)



■ Fully harnessed cable carrier system in shipping crate



■ Assembly of the fully harnessed cable carrier system





## Accessories for steel cable carriers

**Guide channels**  
**Support trays**  
**Support rollers**  
**Steel strip covers**  
**Strain relief devices**

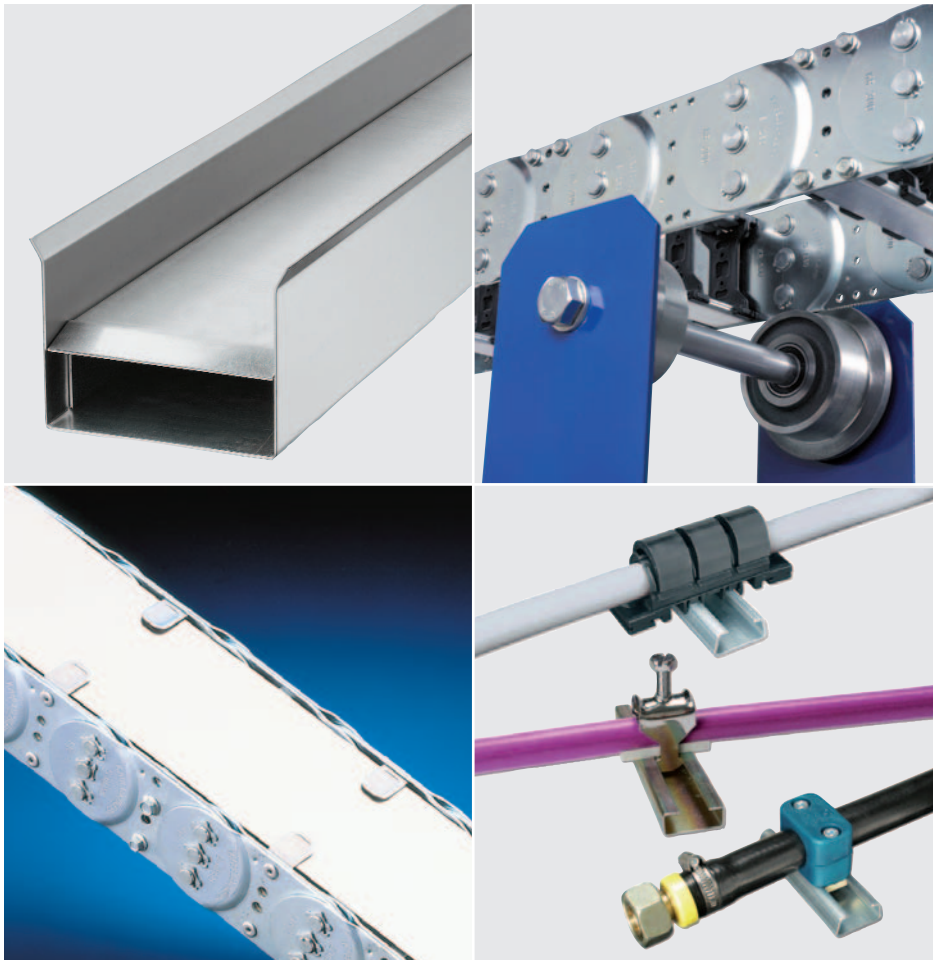

LS/LSX Series

S/SX Series

CONDUFLEX  
MOBIFLEXTRAXLINE  
TOTALTRAX

Accessories

Application  
Examples

# Guide channels made of steel plate for installation variant EBV 05.

Guide channels provide the side guidance of the cable carrier in the sliding arrangement. They prevent the upper trough slipping off the lower trough.

For long travel lengths, the cable carrier upper trough glides on the lower trough and on the gliding surface of the guide channel (see installation variant EBV 05). The graphic 1 on the next page shows this principle.

In order to ensure the gliding of the chain bands, glide shoes are bolted on to the side plates of the cable carrier.

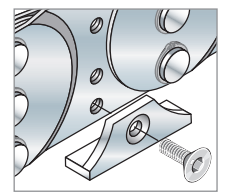
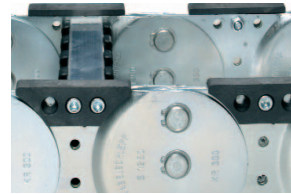

■ Upper trough gliding on the lower trough

■ Standard glide shoes for S/SX 1250

## Standard design

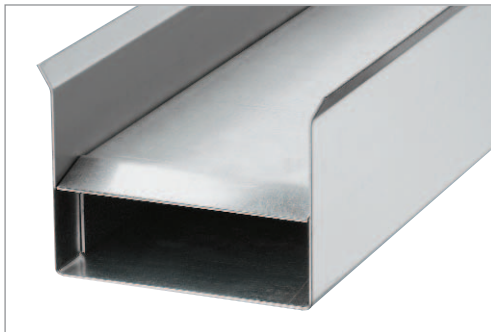

**Materials:** zinc-plated steel plate/  
stainless steel

**Supply length:** standard length 2 m/  
special lengths on request

- very easy and universal assembly – there is no alignment of the channel side walls with each other as there are no loose channel side walls
- large support widths due to stable U construction
- easy fixing options:
  - standard retaining plates
  - direct welding on-site
  - various special solutions with retaining bracket
- optionally as corrosion-resistant, sea water resistant version
- special glide pads are available for reducing glide resistance and wear between cable carrier and support. Please contact us.

## Optional standard fixing with retaining plates

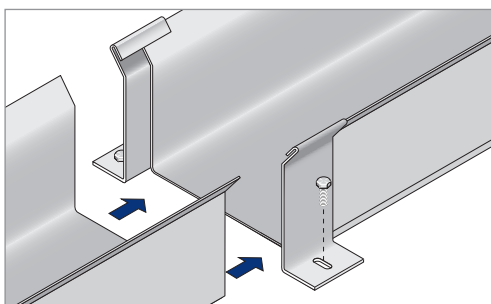

A retaining plate is mounted on the adjoining points and as well as fixing the channel to the floor also guarantees an exact connection of the adjoining points.

- optimum alignment of the adjoining points
- reduced installation times
- minimal number of threaded connections
- secure hold, also in harsh conditions

Please state the channel system when ordering if retaining plates will be needed.

## Calculation of guide channel length $L_{KA}$

### 1 Single-sided arrangement of cable carriers

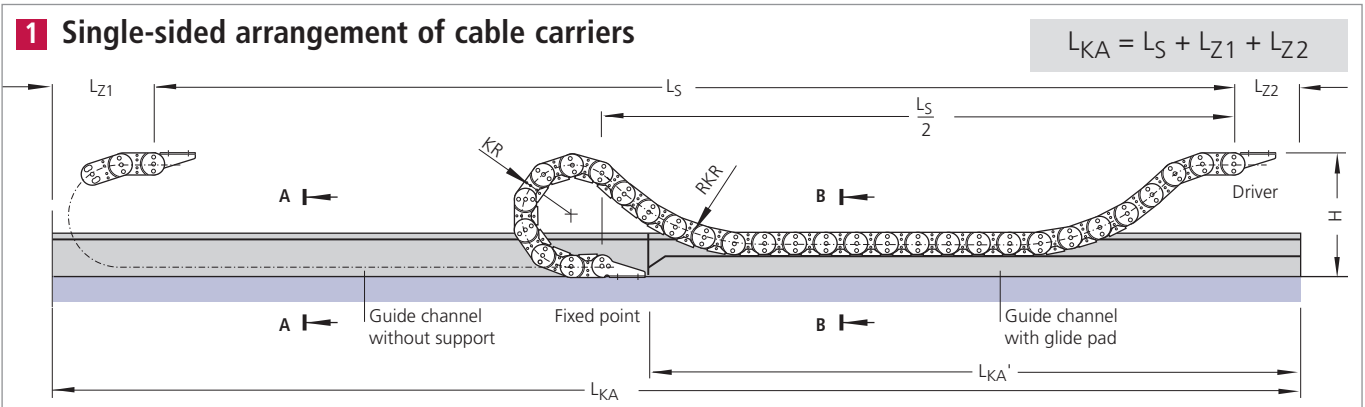

### 2 Opposing arrangement of cable carriers

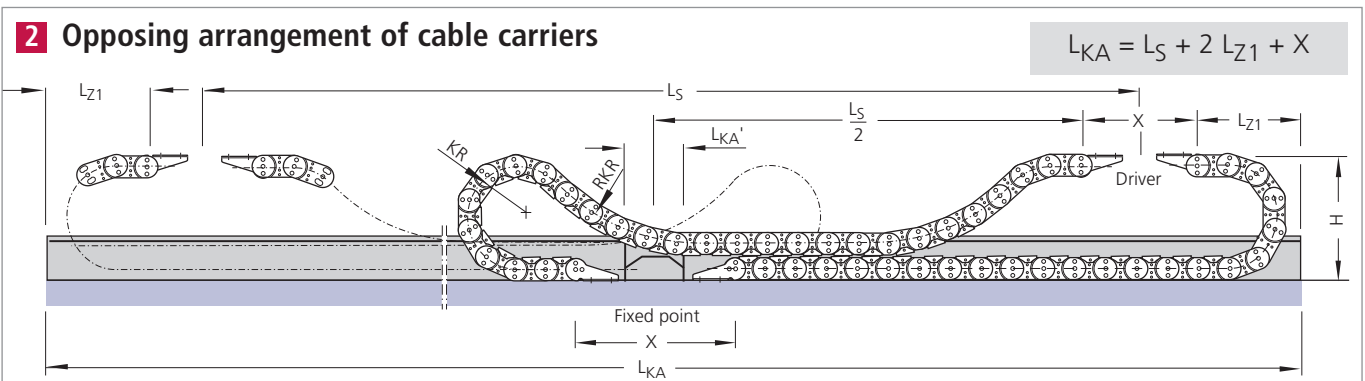

**Abbreviations:**  $L_{KA}$  = Total channel length  
 $L_{KA'}$  = Channel length with support  
 $\triangleq L_S/2$  with single-sided arrangement  
 $\triangleq X - 2 l_1$  with opposing arrangement  
 $L_{Z1}$  = Additional dimension for loop overhang  
 $\triangleq \ddot{U}_B + 50 \text{ mm}$   
 $L_{Z2}$  = Additional dimension for connection  
 $\triangleq l_1 + 50 \text{ mm}$   
 For all other abbreviations see page 5.

## Channel cross-sections

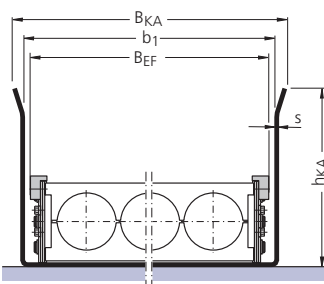

**Cross section A - A**  
Channel profile without support

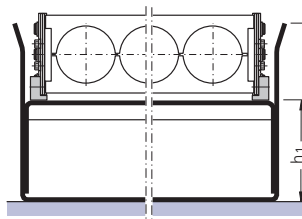

**Cross section B - B**  
Channel profile with support

## Dimensions, channel systems, steel chains

Dimensions in mm

Type	$B_{EF}$	$b_1$	$B_{KA}$	$h_{KA}$	$s$
S/SX 0650	$B_k + 5$	$B_k + 10$	$B_k + 30$	120 for $KR \leq 155$ 200 for $KR > 155$	2
S/SX 0950	$B_k + 9$	$B_k + 14$	$B_k + 34$	150 for $KR \leq 200$ 300 for $KR > 200$	2
S/SX 1250	$B_k + 6$	$B_k + 12$	$B_k + 32$	200 for $KR \leq 300$ 400 for $KR > 300$	3
S/SX 1800	$B_k + 11$	$B_k + 17$	$B_k + 34$	300 for $KR \leq 435$ 500 for $KR > 435$	3

$B_{EF}$  = width of the cable carrier using glide shoes  
 $b_1$  = inside width of the channel  
 $B_{KA}$  = width of the channel  
 $h_{KA}$  = height of the channel  
 $s$  = plate thickness  
 $h_1$  = height of the support

Guide channels for the other series are available on request.

## Examples of guide channels special solutions in steel plate design.

### Bottom open channel

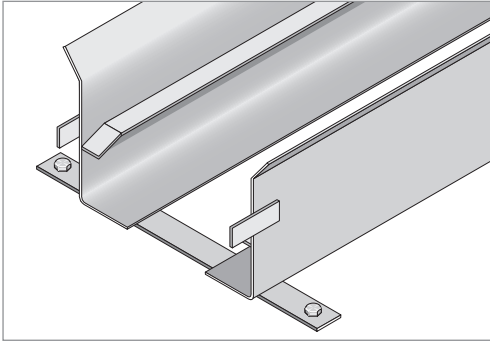

- for fine-grain dirt particles, water, etc. ...
- dust and dirt can drop through the open design below
- application area in washing plants, the woodworking industry, composting plants ...

**STEEL**  
ZINC-PLATED

**STAINLESS  
STEEL**  
RUST-FREE

With TSUBAKI KABELSCHLEPP guide channels, you have various different options for fixing them to the ground or on a support structure as well as the standard fixing.

Also here, no adjoining point offset of the individual channel elements must occur at the connection points, i.e. sidewalls and floor must form a smooth surface.

### Welded-on fixing plates

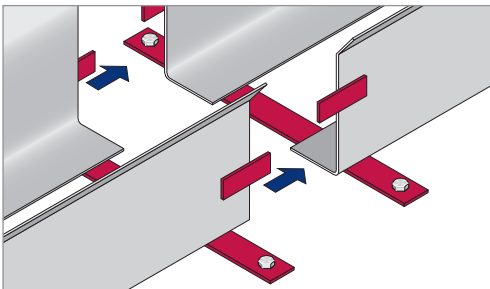

- very easy and universal assembly – there is no alignment of the channel side walls with each other as there are no loose channel side walls
- optimum alignment of the adjoining points
- reduced installation times
- minimal number of threaded connections
- plug-in system

### Unsupported connection points

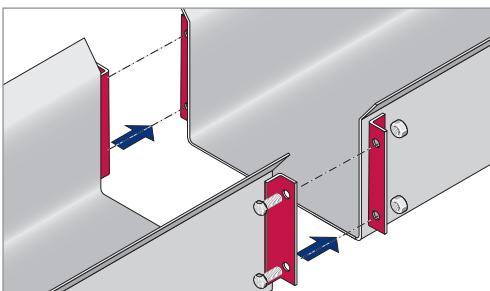

- unsupported adjoining points without support (self-supporting) using flange connections
- secure, fixed connection to adjoining points also for extreme vibrations or in unsupported channel arrangements.

### Fixing with fixing brackets

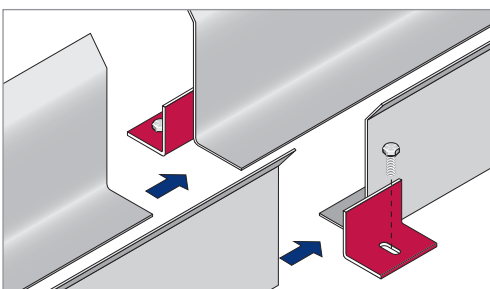

- easy alignment of the adjoining points
- reduced installation times
- minimized number of threaded connections

# Support trays.

A flat surface is required when setting the cable carrier down. If this is not available on site, a support tray must be provided.

**Materials:** zinc-plated steel plate  
stainless steel plate  
aluminium plate

The standard supply length is 2 m.  
Special lengths on request.

### Length of support tray:

$$L_A = \frac{L_S}{2} + \ddot{U}_B + l_1$$

(for standard connection)

$\ddot{U}_B$  = loop overhang

$l_1$  = connection length

$\ddot{U}_B$  and  $l_1$  – see the cable carrier technical data

In the case of strain relief at the fixed point, the length of the support tray must be increased accordingly.

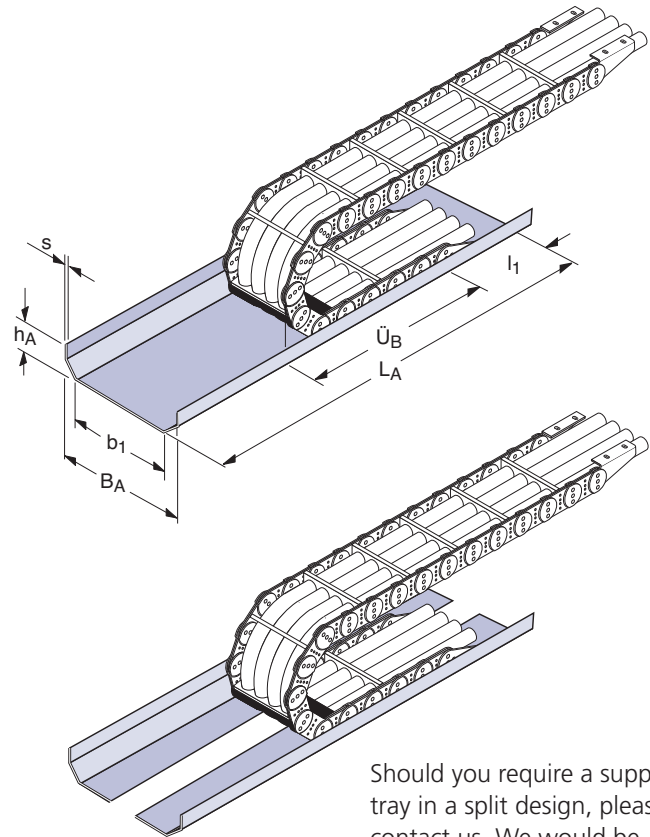

Should you require a support tray in a split design, please contact us. We would be happy to advise you.

## Dimensions table

Dimensions in mm

Type	Clear width $b_1$	Total width $B_A$	Total height $h_A$	Steel sheet thickness
LS/LSX 1050	$B_k + 15$	$B_k + 40$	30	2
S/SX 0650/0950	$B_k + 15$	$B_k + 40$	30	2
S/SX 1250/1850	$B_k + 20$	$B_k + 60$	50	3
S/SX 2500/3200	$B_k + 25$	$B_k + 75$	80	3
S/SX 5000/6000/7000	$B_k + 25$	$B_k + 75$	80	3
CF 055/CF 060	70	85	20	1.5
CF 085	100	115	20	1.5
CF 115	130	155	30	2.0
CF 120	135	160	30	2.0
CF 175	200	225	30	2.0
MF 030.	40	55	20	1.5
MF 050.	70	85	20	1.5
MF 080.	100	115	20	1.5
MF 110.	135	160	30	2.0
MF 170.	200	225	30	2.0

### Example for ordering:

Support tray for cable carrier Type S 0950 –  $B_k$  250 mm  
Length  $L_A$  3200 mm, Material: zinc-plated steel sheet

# Standard support rollers

for types LS/LSX 1050, S/SX 0650, 0950, 1250 and 1800.

- economically priced standard support rollers in light-weight design
- long service life due to ball-bearing rollers
- optimized installation width
- only for use with two-band chains

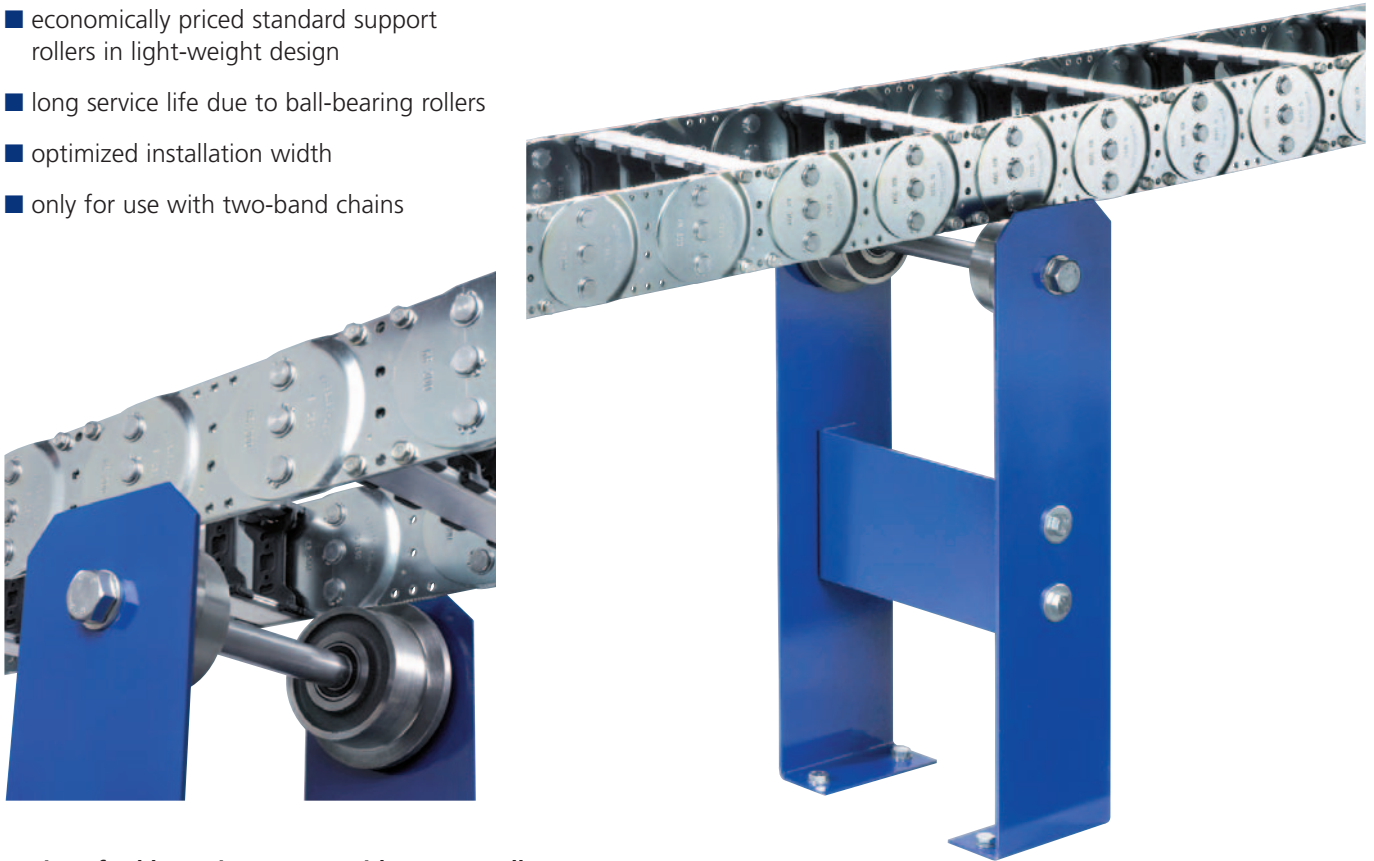

Design of cable carrier systems with support rollers – see page 37.

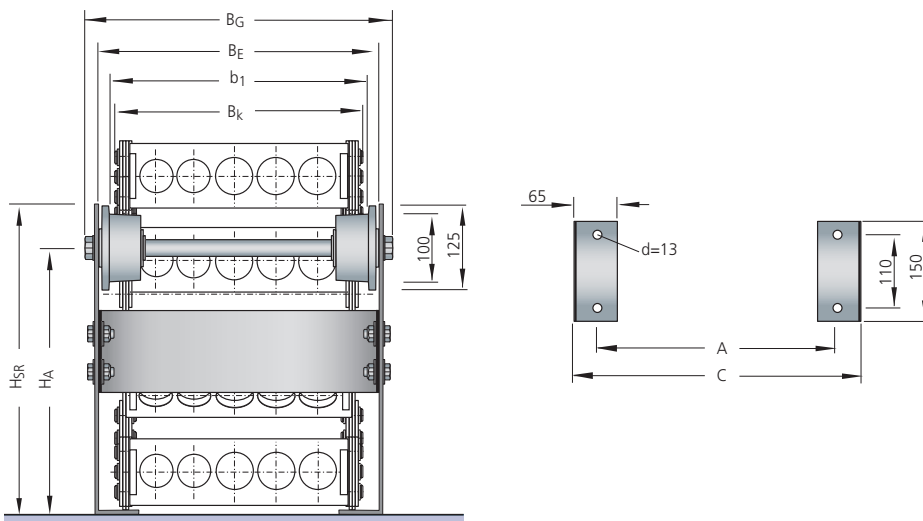

Connection height H for systems with support rollers

$$H = 2 KR + h_g$$

**Abbreviations:**

- $B_k$  = Chain width
- $b_1$  = Clearance width of roller
- $B_G$  = Total width of support
- $B_E$  = Contact width of roller
- $H_A$  = Axle height of support roller
- $H_{SR}$  = Height of the support roller
- $d$  = Diameter of fixing holes

## Standard support rollers dimensions table

Dimensions in mm

$B_E$	$B_G$	$b_1$	$H_{SR}$	$H_A$	A	C
$B_k + 52$	$B_k + 90$	$B_k + 20$	$2 KR + 15$	$2 KR - 50$	$B_k - 10$	$B_k + 60$

# Support rollers with reinforced design for types LS/LSX 1050, S/SX 0650, 0950, 1250 and 1800.

- solid design for extreme loads
- long service life due to ball-bearing roller
- also suitable for multi-band chains
- with hard manganese wear protection for type S/SX and applications with high loads
- also available in stainless steel version

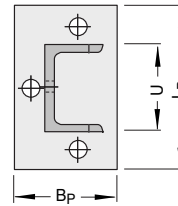
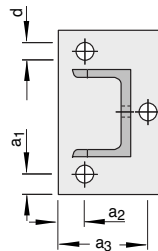
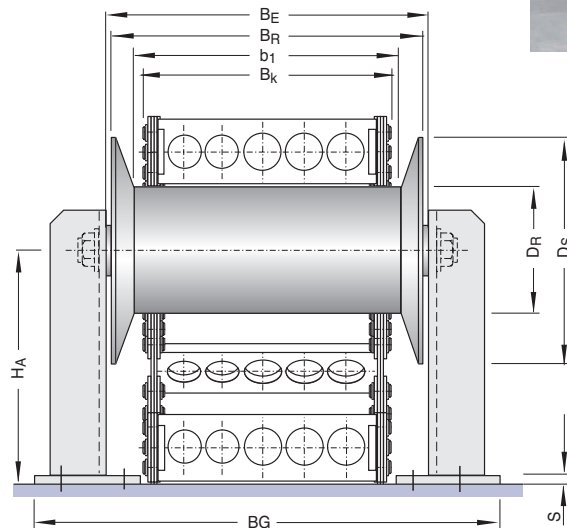

### Abbreviations:

- DR = Diameter of support roller
- DS = Diameter of wheel flange
- Bk = Chain width
- b1 = Clearance width of roller
- BG = Total width of support
- BR = Width of roller
- BE = Contact width of roller
- Bp = Width of base plate
- HA = Axle height of support roller
- H<sub>SR</sub> = Height of the support roller
- Lp = Length of base plate
- U = Width of U profile
- a1 = Hole distance to side edge of base plate
- a2 = Hole distance to outer edge of base plate
- a3 = Hole distance to outer edge of base plate
- d = Diameter of fixing holes
- s = Thickness of base plate

## Reinforced support rollers dimensions table

Dimensions in mm

Type	DR	b <sub>1</sub>	BR	BE	BG	DS
LS/LSX 1050	120	B <sub>k</sub> + 20	B <sub>k</sub> + 50	B <sub>k</sub> + 64	B <sub>k</sub> + 174	Ø 200
S/SX 0650	90	B <sub>k</sub> + 15	B <sub>k</sub> + 45	B <sub>k</sub> + 59	B <sub>k</sub> + 169	Ø 170
S/SX 0950	120	B <sub>k</sub> + 20	B <sub>k</sub> + 50	B <sub>k</sub> + 64	B <sub>k</sub> + 174	Ø 200
S/SX 1250						
S/SX 1800						
S/SX 2500	220	B <sub>k</sub> + 30	B <sub>k</sub> + 60	B <sub>k</sub> + 74	B <sub>k</sub> + 184	Ø 300

## Support blocks dimensions table

Dimensions in mm

Type	HA	Bp	Lp	U	a <sub>1</sub>	a <sub>2</sub>	a <sub>3</sub>	d	s
S/SX 1050	2 KR – 60	100	180	80	20	20	80	Ø 18	8
S/SX 0650	2 KR – 45	80	180	80	20	40	---	Ø 14	8
S/SX 0950	2 KR – 60	100	180	80	20	20	80	Ø 18	8
S/SX 1250									
S/SX 1800									
S/SX 2500	2 KR – 110	100	180	80	20	20	80	Ø 18	8

Support rollers for other types on request.

# Steel strip covers.

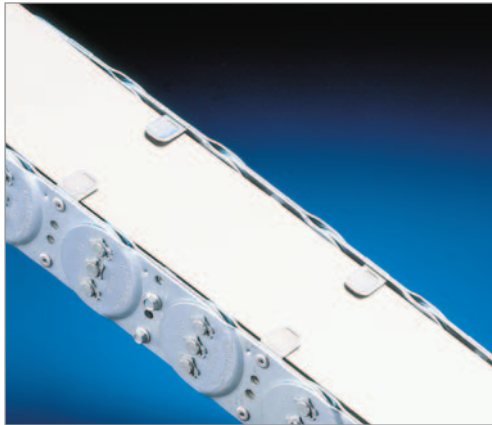

Steel strip covers made of rust and acid resistant spring steel strip can be supplied for protection of the cables against flying sparks, radiant heat and small chips. **Note:** Only applicable with horizontal single cable carrier (within the radius of curvature, no reverse bending).

- economically priced cover variant for half-stay version
- made of rust and acid resistant spring steel strip
- maximum steel band width: 1000 mm

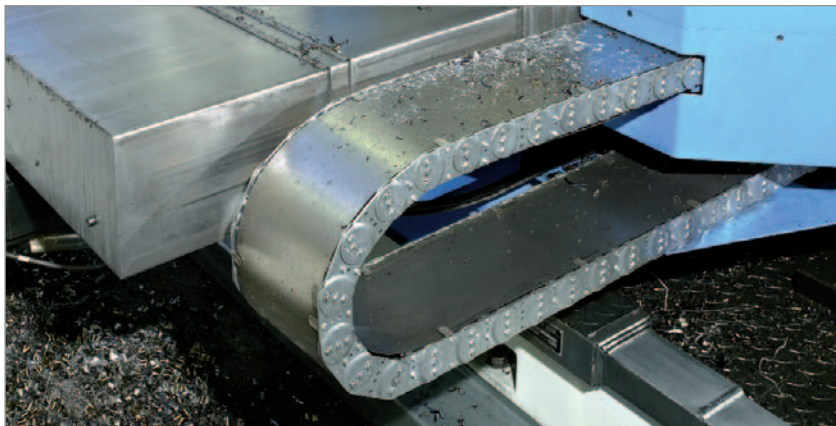
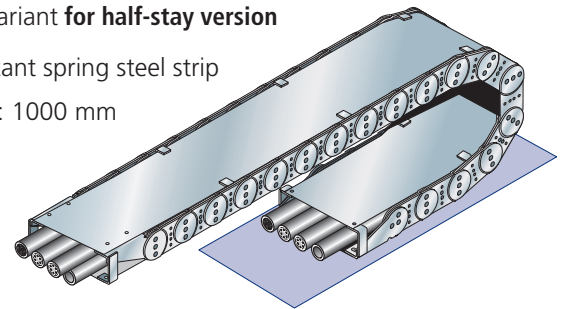

## Dimensions Table

Dimensions in mm

Type	Length of steel strip cover		Width of steel strip cover
	Outer cover	Inner cover	
S/SX 0650	$L_k + 280$	$L_k + 130$	$B_k - 22$
S/SX 0950	$L_k + 360$	$L_k + 150$	$B_k - 27$
S/SX 1250	$L_k + 470$	$L_k + 170$	$B_k - 34$
S/SX 1800	$L_k + 640$	$L_k + 200$	$B_k - 40$
S/SX 2500	$L_k + 945$	$L_k + 255$	$B_k - 48$

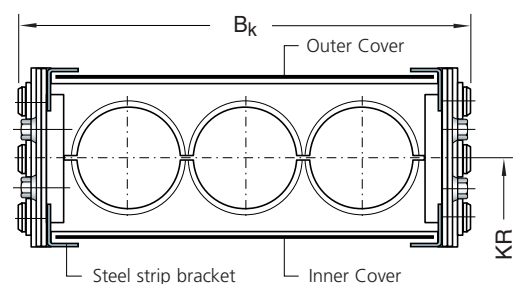

Steel band covers for the other types are available on request.

## Fixing of steel strip cover



- Steel band holder on the sidebands.

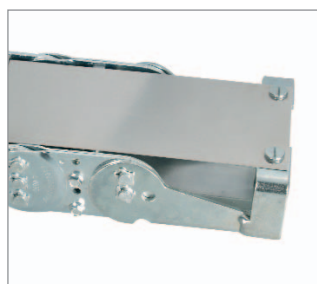

- Fastening to the chain connection with special end connector.





# Strain relief components.

Strain relief for cables is dependant upon the cable type, total carrier length and installation situation. See "Strain relief of cables and hoses" on page 52.

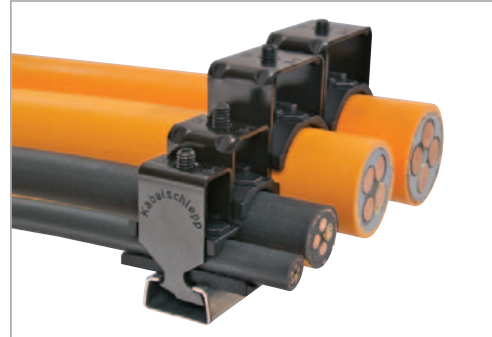

In the case of cable carriers with upper and lower trough sliding on each other (installation variant EBV 05), the installation height of the strain relief must not be higher than the chain link height.

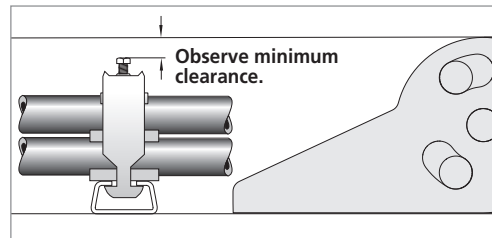

## Overview of strain relief elements

### LineFix saddle-type clamps

- optimized base geometry for secure seating in C-rail
- for one cable and two or three cables on top of each other
- for C-rails with a slot width of 11 mm

Siehe Seite 175.



### Saddle-type clamps Type B

- for C-rails with a slot width of 16 – 17 mm

Siehe Seite 176.

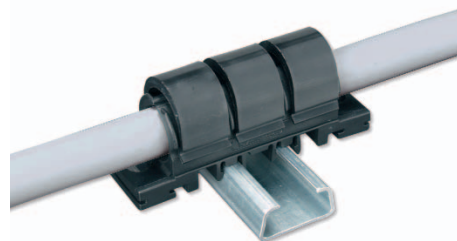

### SZL strain relief devices

- gentle on the cable due to large surface area for enclosing the cables
- simple installation without tools

Siehe Seite 177.



### Block clamps

- for the strain relief of hoses

See page 178.

## Positioning of strain relief components

### LS/LSX Series

- The C-Rail is fixed in the end connector and must not be bolted separately.
- Length of the C-Rail  $L_p$   
 driver:  $L_p = B_i + 4 \text{ mm}$   
 fixed point:  $L_p = B_i$

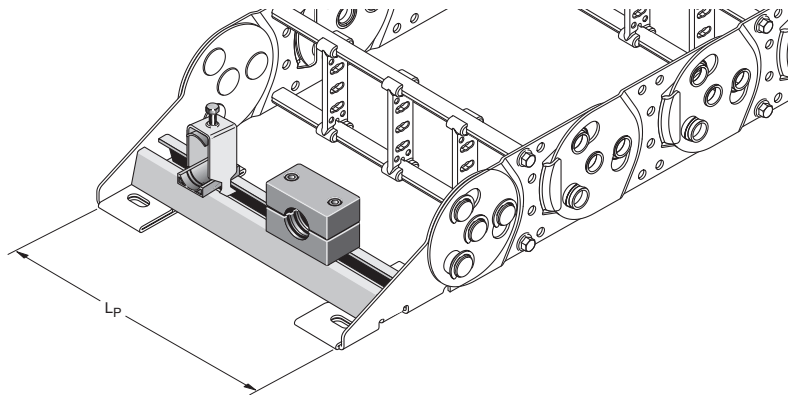

### Type S/SX 1050

**C-Profile suitable for brackets with small base (slot width 11 – 12 mm).**

C-Profile dimensions, see page 179, order no. 3934.

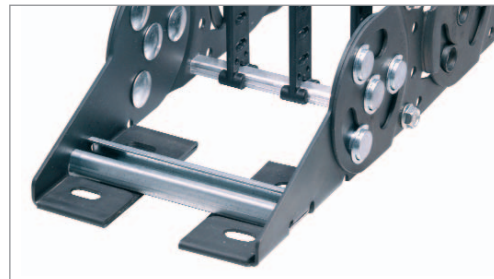
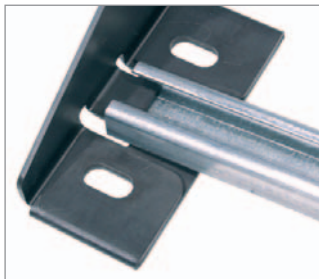

■ Inserting the C-Rail in the end connector

■ C-Rail fixed in the end connector

### S/SX Series

- C-Profile and C-Rail are mounted behind the end connectors.
- Strain relief at the fixed point connection and at the driver connection are identical.
- Profile length  $L_p \hat{=} \text{chain width } B_k$

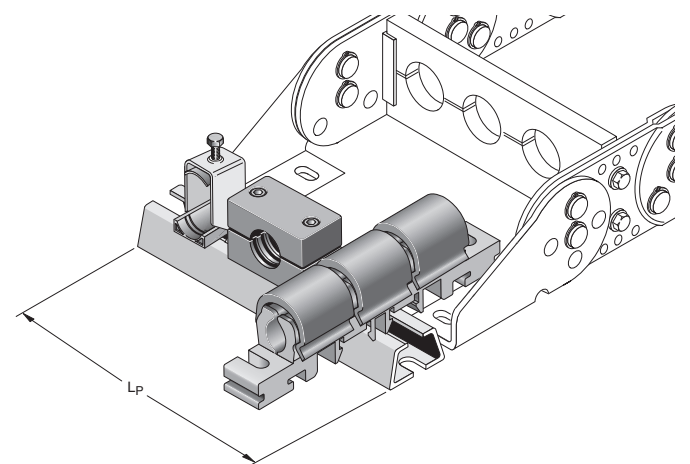
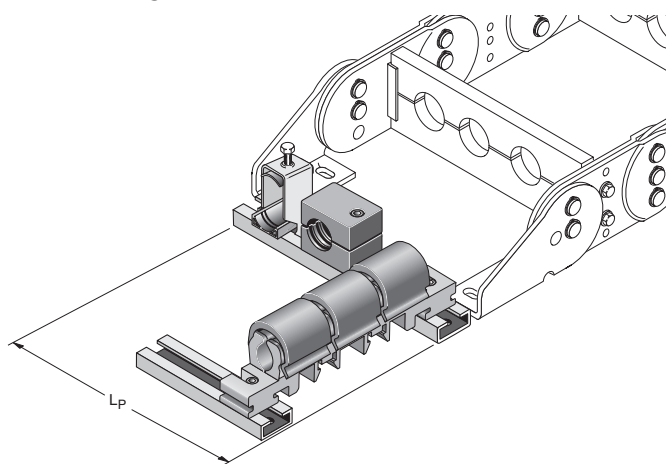

### Types S/SX 0650, 0950, 1250, 1800

**C-Profile suitable for brackets with small base (slot width 11 – 12 mm).**

C-Profile dimensions, see page 179, order no. 3931/3935/3934.

Fasten profile with cylindrical screws M6 – DIN 6912.

### Types S/SX 1250, 1800, 2500

**C-Profile suitable for brackets with large base (slot width 16 – 17 mm).**

C-Profile dimensions, see page 179, order no. 3926/3932.



Fasten profile with cylindrical screws M10 – DIN 6912.

**Strain relief equipment for all other series is available on request!**

## SZL strain relief devices

- for C-rails with a slot width of 11 mm
- for one, two or three cables on top of each other
- optimized base geometry for secure seating in the C-profile
- high quality corrosion protection of the coated housing through cathode immersion painting
- pan design with retaining ribs for secure fixing of the cables
- rounded design of the pan elements is gentle on the cables

## Strain relief elements for series 1050, 0650 and 0950

LineFix Type	Designation	Material no. for a complete LineFix	Material no. for a complete LineFix stainless steel	Min. cable Ø	Max. cable Ø	Number of cables	Width	Total height with max. cable Ø incl. C-rail*
<b>Single clamps</b> 	LF 12-1	13630	13731	6	12	1	16	55
	LF 14-1	13631	13732	12	14	1	18	52
	LF 16-1	13632	13733	14	16	1	20	54
	LF 18-1	13633	13734	16	18	1	22	56
	LF 20-1	13634	13735	18	20	1	24	59
	LF 22-1	13635	13736	20	22	1	26	61
	LF 26-1	13636	13737	22	26	1	30	70
	LF 30-1	13637	13738	26	30	1	34	74
	LF 34-1	13638	13739	30	34	1	38	78
	LF 38-1	13639	13740	34	38	1	42	82
LF 42-1	13640	13741	38	42	1	46	91	
<b>Double clamps</b> 	LF 12-2	13641	13742	6	12	2	16	73
	LF 14-2	13642	13743	12	14	2	18	74
	LF 16-2	13643	13744	14	16	2	20	82
	LF 18-2	13644	13745	16	18	2	22	86
	LF 20-2	13645	13746	18	20	2	24	91
	LF 22-2	13646	13747	20	22	2	26	95
	LF 26-2	13647	13748	22	26	2	30	108
	LF 30-2	13648	13749	26	30	2	34	121
LF 34-2	13649	13750	30	34	2	38	129	
<b>Triple clamps</b> 	LF 12-3	13650	13751	6	12	3	16	98
	LF 14-3	13651	13752	12	14	3	18	98
	LF 16-3	13652	13753	14	16	3	20	105
	LF 18-3	13653	13754	16	18	3	22	111
	LF 20-3	13654	13755	18	20	3	24	118
	LF 22-3	13655	13756	20	22	3	26	130

Material No.: 3934

### Secure seating and easy assembly.

The retaining lug fixes the base securely in the C-profile in the screwed-on state and prevents the clamp from rocking out in case of tensile and compressive loads, regardless of the installation direction.

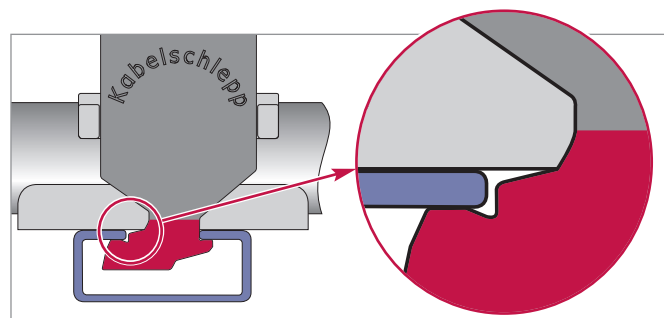

### Pan design construction with optimized geometry.

Curved retaining ribs contain the cables in a safe and gentle manner.

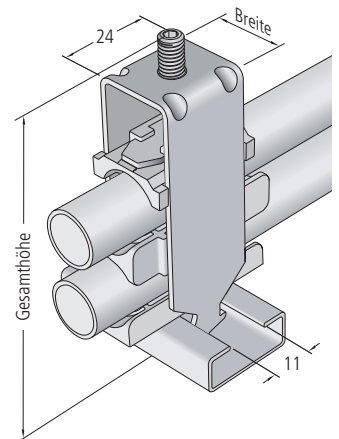
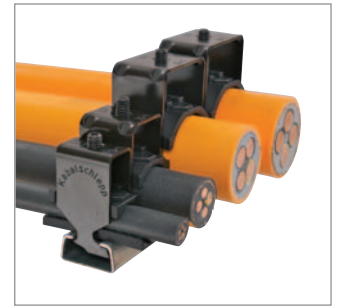

The total height specification is an approximate value. The actual height depends on the diameter and characteristics of the cables, among other things.



Simple installation even in confined spaces with a hexagonal socket stud.

LS/LX Series

S/SX Series

CONDUFLEX  
MOBIFLEX

TRAXLINE  
TOTALTRAX

Accessories

Application  
Examples

## Saddle-type clamps Type B (For clamps with large base)

■ for C-rails with a slot width of 16 – 17 mm

### Strain relief elements for series 1250, 1800 and 2500

#### Single clamps – for one cable

Type	Cable-Ø	Opposite sleeve GW	Double sleeve DW
B 12	6 – 12	GW 12	–
B 14	10 – 14	GW 14	–
B 16	12 – 16	GW 16	–
B 18	14 – 18	GW 18	–
B 22	18 – 22	GW 22	–
B 26	22 – 26	GW 26	–
B 30	26 – 30	GW 30	–
B 34	30 – 34	GW 34	–
B 38	34 – 38	GW 38	–
B 42	38 – 42	GW 42	–
B 46	42 – 46	GW 46	–
B 50	46 – 50	GW 45	–

Dimensions in mm

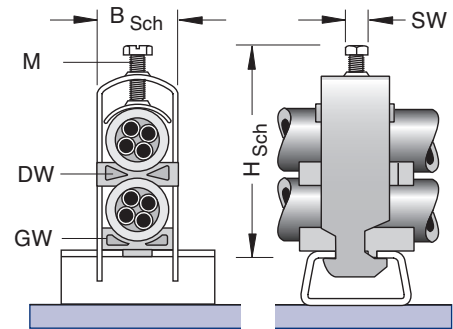

#### Assembly profile bars

suitable for all common commercially available saddle-type clamps with **large** base (slot width 16 – 17 mm).

**Material:** Aluminium Steel  
**Item-No:** 3926 3932

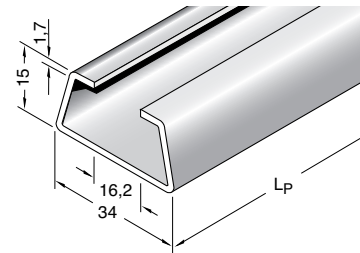

#### Double clamps – for two cables on one top of the other

Type	Cable-Ø	Opposite sleeve GW	Double sleeve DW
B 12/2	6 – 12	GW 12	DW 12
B 14/2	10 – 14	GW 14	DW 14
B 16/2	12 – 16	GW 16	DW 16
B 18/2	14 – 18	GW 18	DW 18
B 22/2	18 – 22	GW 22	DW 22
B 26/2	24 – 26	GW 22	DW 26
B 30/2	28 – 30	GW 22	DW 30
B 34/2	32 – 34	GW 22	DW 34
B 38/2	36 – 38	GW 22	DW 38
B 42/2	40 – 42	GW 22	DW 42

Dimensions in mm

#### Triple clamps – for three cables stacked on the top of each other

Type	Cable-Ø	Opposite sleeve GW	Double sleeve DW
B 12/3	12	GW 12	DW 12
B 14/3	14	GW 14	DW 14
B 16/3	16	GW 16	DW 16
B 18/3	18	GW 18	DW 18
B 22/3	22	GW 22	DW 22
B 26/3	26	GW 26	DW 26
B 30/3	30	GW 30	DW 30

Dimensions in mm

Other sizes and designs available on request!

## SZL strain relief devices

- economically priced
- installation – easy, fast and without tools
- gentle on cables due to large surface area contact with the cables
- small installation height
- without screws and cable binders
- defined contact pressure exerted by spring clamps
- suitable for common commercially available support rails
- immune to vibration
- long service life for dynamic applications
- can also be used as strain relief in switch cabinets



### Available sizes

Dimensions in mm

Type	Ident-No.	For cable-Ø	Width B at		Height H
			Ø min	Ø max	
SZL 8	24989	> 5,0 - 8,0 mm	16	16	28
SZL 10	24990	> 8,0 - 10,5 mm	20	20	30
SZL 14	24991	>10,5 - 14,5 mm	23	26	35
SZL 18	24992	>14,5 - 18,0 mm	25	32	40
SZL 22	24993	>18,0 - 22,0 mm	30	36	44
SZL 27	24994	>22,0 - 27,0 mm	34	39	50
SZL 32	24995	>27,0 - 32,0 mm	39	44	56

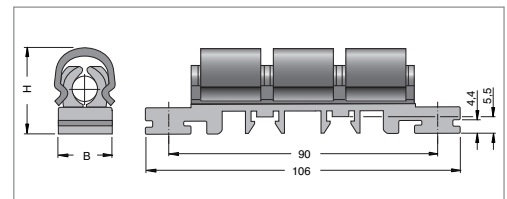

### Fixing options



1. By clipping into C-Profiles.



2. By clipping onto cap bar.

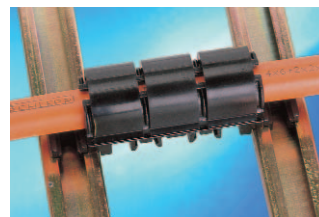

3. By pushing into two C-Profile bars.



4. By directly screwing.

Solutions 3 and 4 make the transmission of large tensile forces possible and are therefore recommended as standard solutions.

### Installation of the SZL strain relief device



## Block clamps for series 1050, 0650 to 1800

- for strain relief of hoses
- with clamping bolt(s) and mounting rail nut(s)

### Single clamps – one cable

#### Type BS 0

Dimensions in mm

Type	For cable Ø	Height H <sub>Sch</sub>	Width B <sub>Sch</sub>	Bolts		Item-No.
				M6 – DIN 6912 Number	Length	
BS 0.06	6 mm	26	28	1	35	16701
BS 0.07	6.5 mm	26	28	1	35	16702
BS 0.08	8 mm	26	28	1	35	16703
BS 0.09	9.5 mm	26	28	1	35	16704
BS 0.10	10 mm	26	28	1	35	16705

Other sizes and designs available on request!



#### Type BS 0. \_

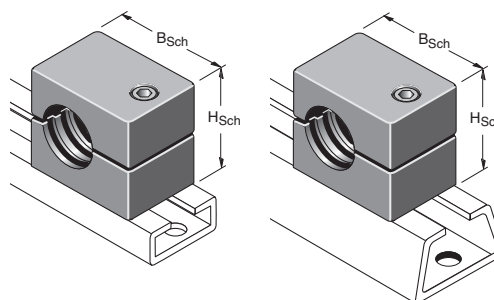

#### Assembly profile bars:

**Material: Steel**  
Item-No.: 3931

**Material: Steel**  
Item-No.: 3934

#### Type BS 1 – BS 5

Dimensions in mm

Type	For cable Ø	Height H <sub>Sch</sub>	Width B <sub>Sch</sub>	Bolts		Item-No.
				M6 – DIN 6912 Number	Length	
BS 1.06	6 mm	26	34	2	35	16706
BS 1.07	6.5 mm	26	34	2	35	16707
BS 1.08	8 mm	26	34	2	35	16708
BS 1.09	9.5 mm	26	34	2	35	16709
BS 1.10	10 mm	26	34	2	35	16710
BS 1.12	12 mm	26	34	2	35	16711
BS 2.14	14 mm	32	40	2	40	16712
BS 2.16	16 mm	32	40	2	40	16713
BS 2.18	18 mm	32	40	2	40	16714
BS 3.20	20 mm	36	48	2	45	16715
BS 3.22	22 mm	36	48	2	45	16716
BS 3.23	25 mm	36	48	2	45	16717
BS 3.25	25.5 mm	36	48	2	45	16718
BS 3.27	27 mm	36	48	2	45	16719
BS 3.30	30 mm	36	48	2	45	16721
BS 4.32	32 mm	56	69	2	65	16722
BS 4.34	34 mm	56	69	2	65	16723
BS 4.35	35 mm	56	69	2	65	16724
BS 4.38	38 mm	56	69	2	65	16725
BS 4.40	40 mm	56	69	2	65	16726
BS 4.42	42 mm	56	69	2	65	16727
BS 5.45	44.5 mm	65	85	2	75	16728
BS 5.48	48.5 mm	65	85	2	75	16729
BS 5.51	51 mm	65	85	2	75	16731

Other sizes and designs available on request!

#### Type BS 1. \_ - BS 5. \_

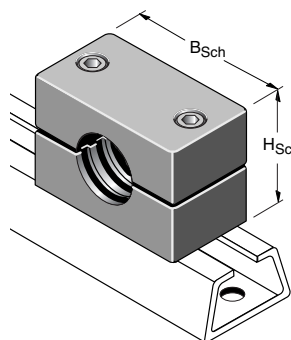

#### Assembly profile bars:

**Material: Aluminium**  
Item-No.: 3926

**Material: Steel**  
Item-No.: 3932

Material of the clamping jaws: PP

## Assembly profile bars for strain relief elements



### C-Profile 25 x 10 mm for S/SX 0650/0950

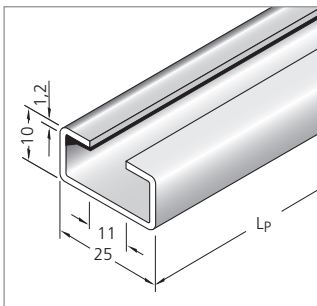

Fits all commercial clamps  
(slit width 11 mm),  
Types LineFix see page 175.

<b>Material</b>	<b>Item-No.</b>
Steel	3931

Attach profile with M 6 – DIN 6912 sockethead cap screws.

### C-Rail 25 x 12 mm for LS/LSX 1050, S/SX 0650/0950

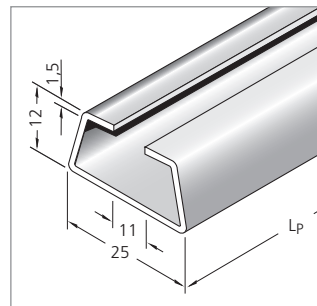

Fits all commercial clamps  
(slit width 11 mm),  
Types LineFix see page 175.

<b>Material</b>	<b>Item-No.</b>
Steel	3934

**LS/LSX 1050:** is fixed in the end connector; must not be bolted separately.

**S/SX 0650/0950:** Attach profile with M 6 – DIN 6912 sockethead cap screws.

### C-Rail 34 x 15 mm für S/SX 1250/1800 und 2500

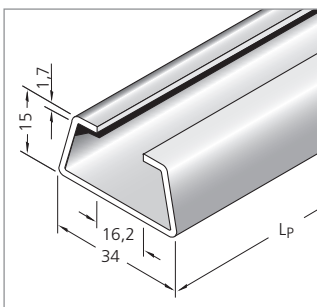

Fits all commercial clamps  
(slit width 16 – 17 mm),  
Types B see page 176.

<b>Material</b>	<b>Item-No.</b>
Aluminium	3926
Steel	3932

Attach profile with M 6 – DIN 6912 sockethead cap screws.

### C-Rail 34 x 15 mm für S/SX 1250/1800

(bei Verwendung von LineFix Bügelschellen)

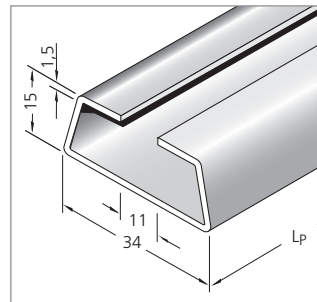

Fits all commercial clamps  
(slit width 11 mm),  
Types LineFix see page 175.

<b>Material</b>	<b>Item-No.</b>
Steel	3935

Attach profile with M 6 – DIN 6912 sockethead cap screws.

# Fax Enquiry Form

Telefax: +49 2762/4003-220

**From:**

Company: \_\_\_\_\_

Contact: \_\_\_\_\_ Department: \_\_\_\_\_

Phone: \_\_\_\_\_ Telefax: \_\_\_\_\_ Email: \_\_\_\_\_

**Please submit exact specifications in order for us to plan a solution for your application. We would be pleased to submit a comprehensive proposal based on your enquiry!**

Please have an applications engineer call for an appointment!

Proposal for:

**Enquiry number:** \_\_\_\_\_

**Cable carriers including enclosed designs**

Zinc-plated steel

Rust acid resistant stainless steel

Steel – specially coated

CONDUFLEX

MOBIFLEX

**Accessories**  Support trays  Guide channels

TRAXLINE

Strain relief devices

We require the following information to prepare a proposal:

**1.00 Machinery data**

- .10 Application \_\_\_\_\_
- .20 Environmental conditions \_\_\_\_\_
- .21 Ambient operating temperature \_\_\_\_\_ °C
- .30 Maximum machine travel length  $L_s$  \_\_\_\_\_ mm
- .40 Max. acceleration/deceleration \_\_\_\_\_  $m/s^2$
- .50 Travel speed \_\_\_\_\_ m/s
- .60 Travel frequency \_\_\_\_\_ times/h
- .70 Installation situation (drawing/outline) \_\_\_\_\_
- .71 Max. installation height H \_\_\_\_\_ mm
- .72 Max. installation width B \_\_\_\_\_ mm
- .73 Installation variant EBV \_\_\_\_\_

**Terms:**

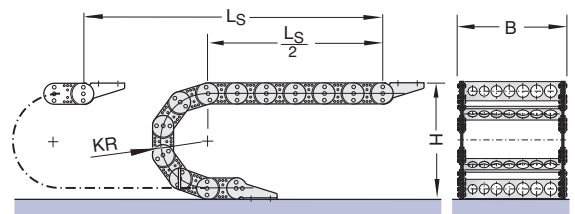

**2.00 Supply cables/hoses**

electr.	Cable type			Number of cables	Cable cross section (e.g. 4x6 mm <sup>2</sup> )	Ø in mm	Hose diameter at operating pressure in mm	Number of pressure oscillations per hour	Weight in kg/m	Minimum bend radius in mm	Cables with fixed plugs or terminal fittings
	pneum.	hydr.	Fibre-optic cables								

**3.00 Supplementary information:**

\_\_\_\_\_  
 \_\_\_\_\_  
 \_\_\_\_\_



# Information request

Telefax: +49 2762/4003-220



Please send me the following catalogue / information material:

- Innovations brochure
- General Catalog
- Solutions for steel mills brochure
- TRAXLINE Cables for Motion catalogue – electrical cables for cable carriers
- Range of services brochure – the TSUBAKI KABELSCHLEPP product range
- CD-ROM – spare parts lists and brochure material in PDF format
- CD-ROM – 2D/3D data of cable carrier systems

From:

Company: \_\_\_\_\_

Name: \_\_\_\_\_

Position: \_\_\_\_\_

Address: \_\_\_\_\_

ZIP code: \_\_\_\_\_ Town: \_\_\_\_\_

Phone: \_\_\_\_\_

Telefax: \_\_\_\_\_

Email: \_\_\_\_\_



Steel cable carriers

# Application examples

LS/LX Series

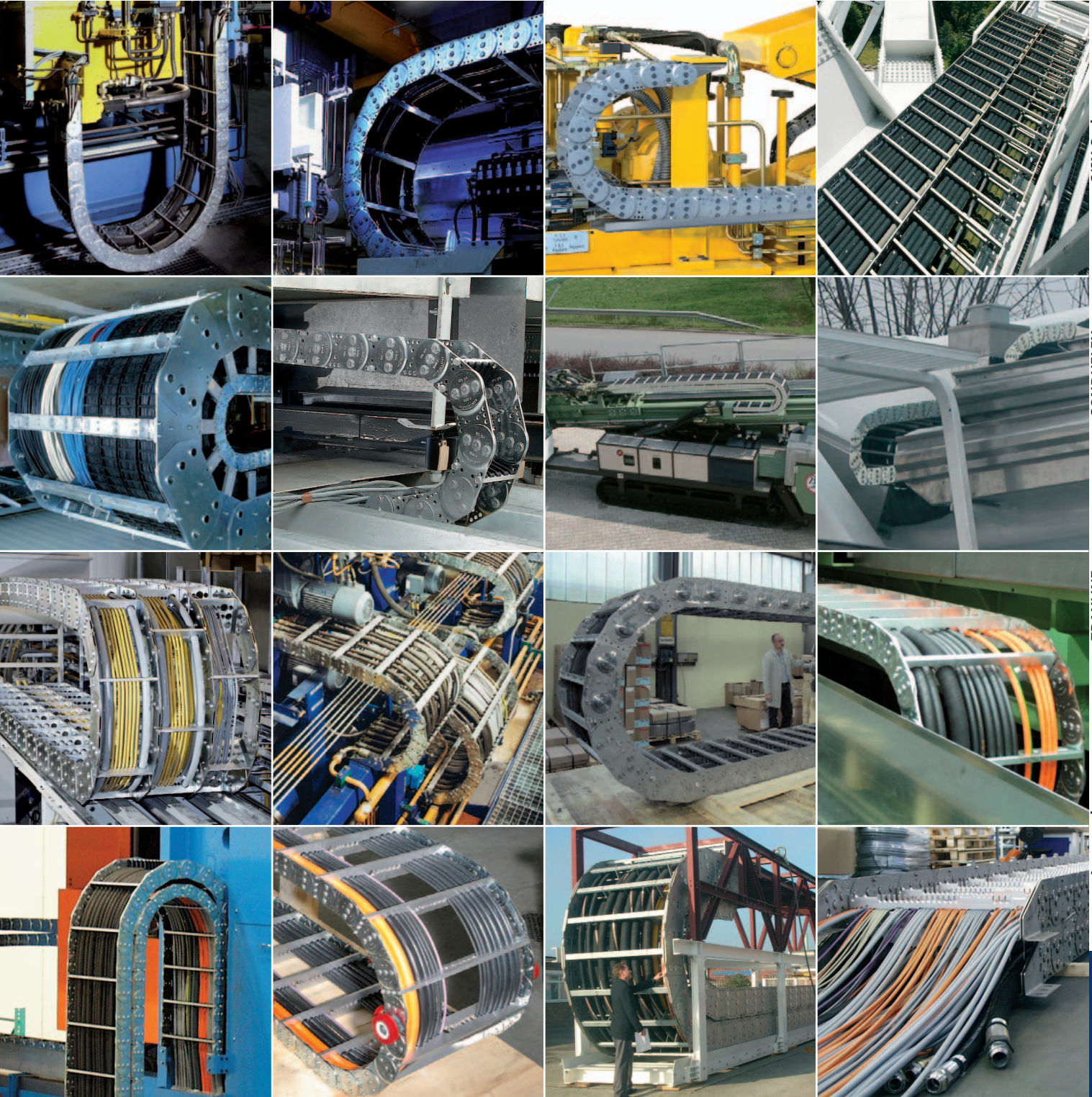

S/SX Series

CONDUFLEX  
MOBIFLEX

TRAXLINE  
TOTALTRAX

Accessories

Application  
Examples

# Application examples.

Steel cable carriers.

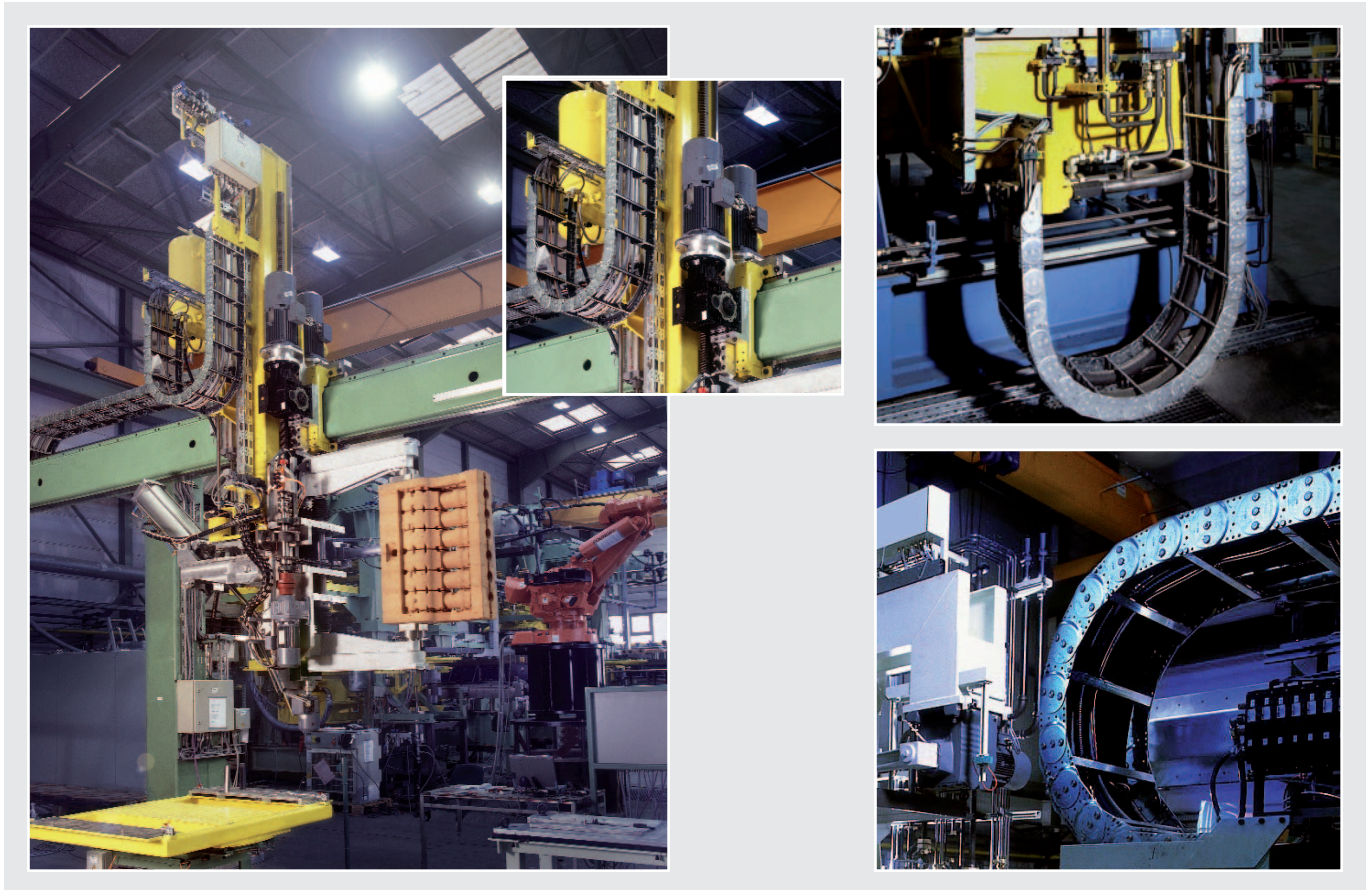

Steel cable carriers on a manipulator for handling crankcase core stackings.  
Photographs: Hottinger Maschinenbau GmbH



Steel cable carrier on a scissored coil lift. Photographs: SKO Steiner GmbH



Steel cable carriers with aluminium cover system on a radio telescope.  
Photographs: Max-Planck-Institut für Radioastronomie

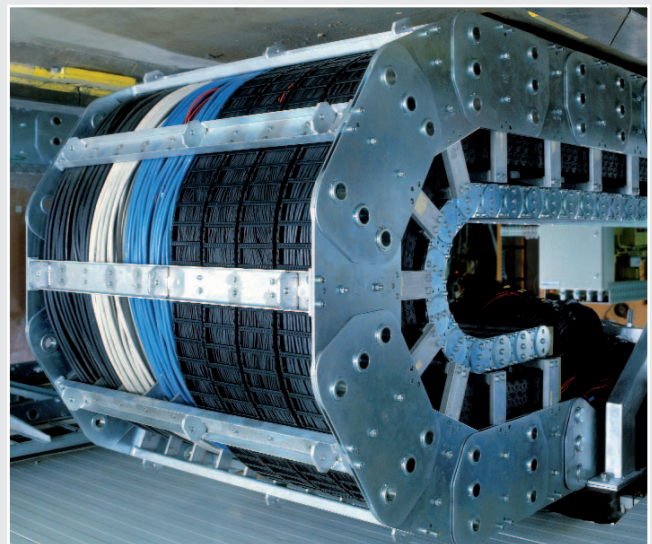
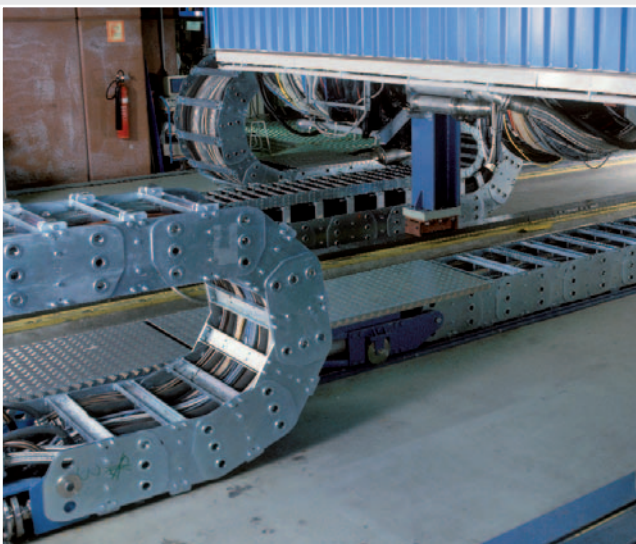

Steel cable carriers with plastic cable carriers for separating the cables on a ZEUS detector.  
Photograph: Deutsches Elektronen-Synchrotron, Hamburg

## Steel cable carriers.



Steel cable carriers on a movable roof construction. Photographs: Lindenschmidt KG





LS/LSX Series

S/SX Series

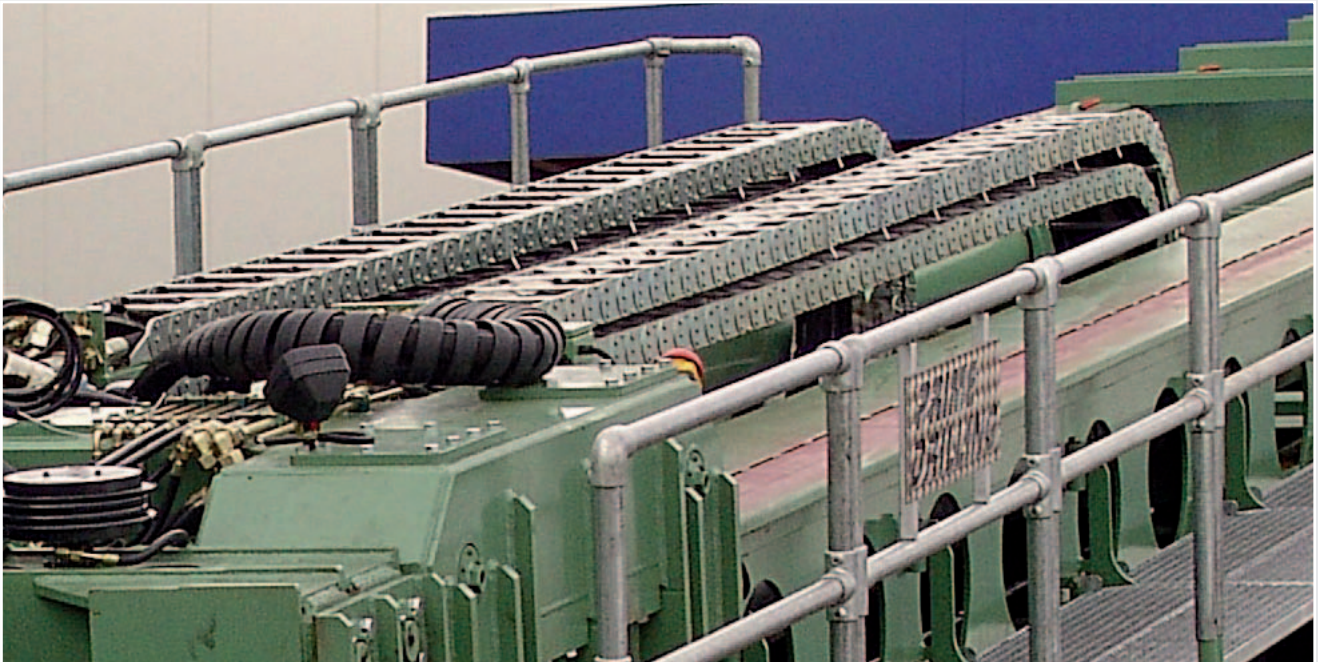

CONDUFLEX  
MOBIFLEX

TRAXLINE  
TOTALTRAX

Steel cable carriers on a drilling system. Photograph: Prime Drilling GmbH



Accessories

Steel cable carriers on telescopic lifts.

## Steel cable carriers.

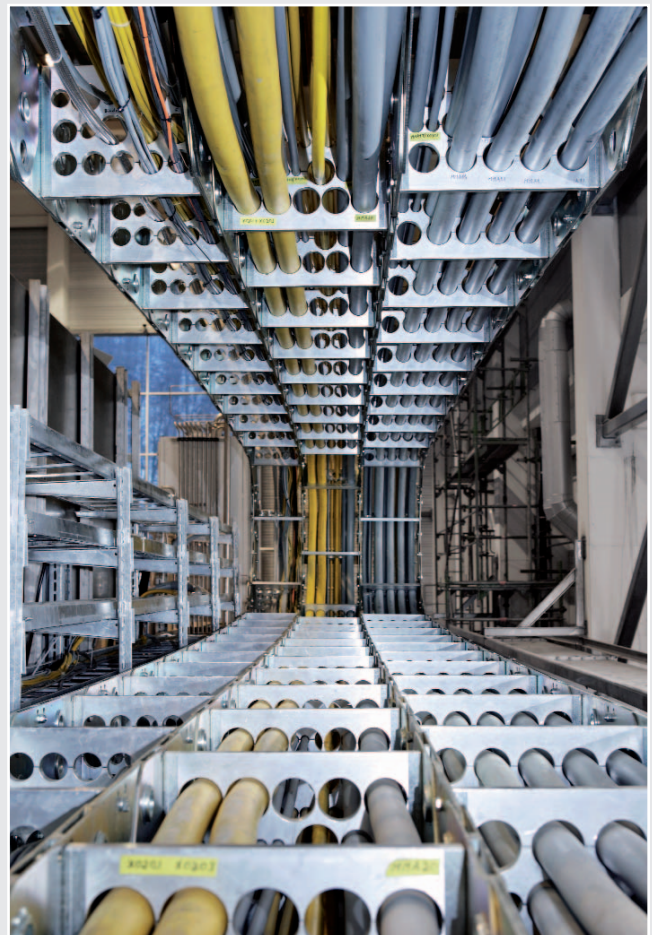
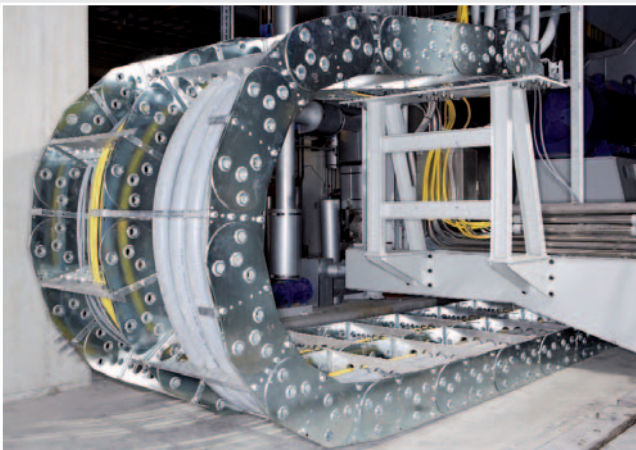
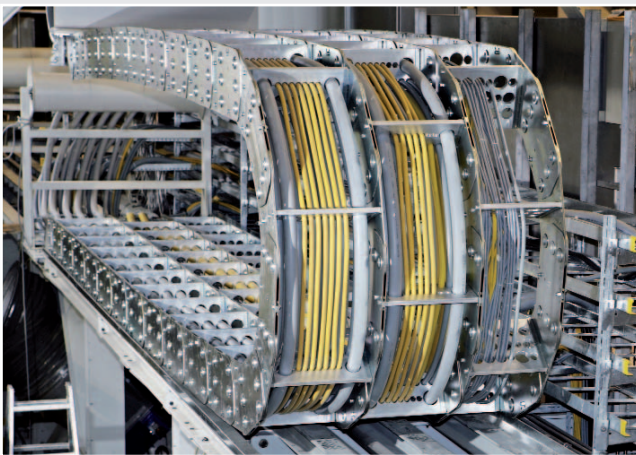

Steel cable carriers on a paper machine. Photographs: Voith Paper Technology Center GmbH



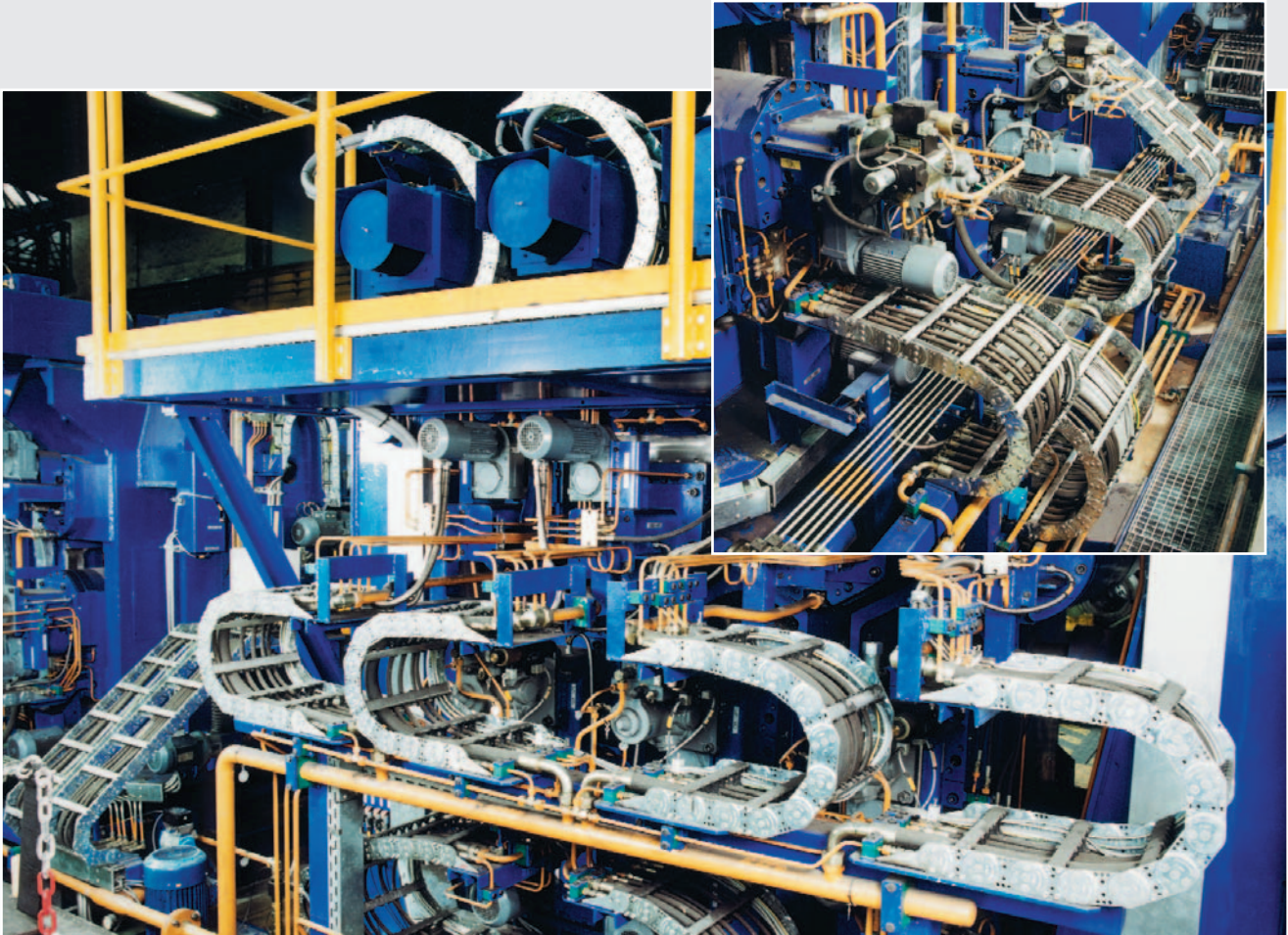

Steel cable carriers on a profile straightening machine. Photographs: Sondermaschinenbau Wildau GmbH & Co. KG



Steel cable carriers with load-bearing bolts. Photograph: Rottler GmbH



Steel cable carriers on a laser cutting machine. Photographs: Meyer Werft GmbH

## Steel cable carriers.

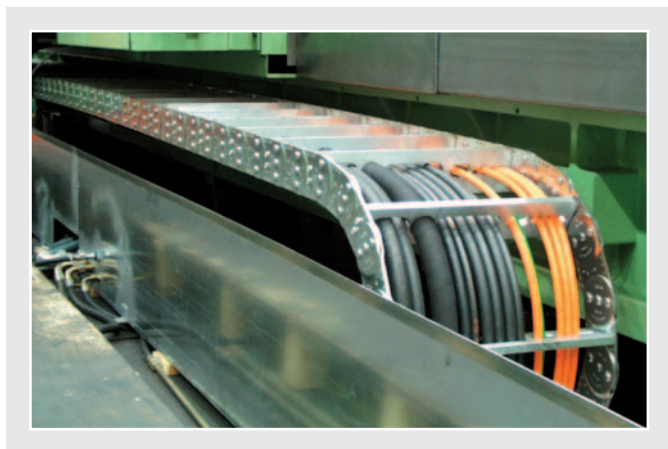

Steel cable carriers with hole stays.



CONDUFLEX cable carrier tubes on a roll grinding machine.  
Photograph: Waldrich Siegen Werkzeugmaschinen GmbH



Steel cable carriers on a gantry milling machine. Photograph: Waldrich Siegen Werkzeugmaschinen GmbH

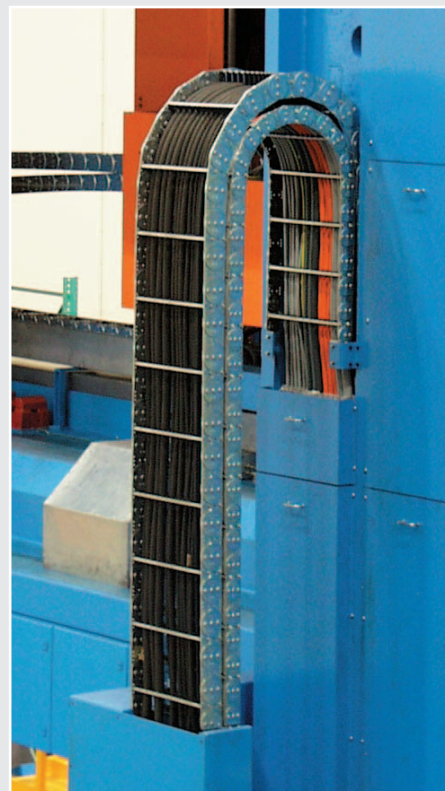



Steel cable carriers with TRAXLINE Cables for Motion on transport frame.



Steel cable carriers with hydraulic hoses.



Steel cable carriers with hole stays.

## Steel cable carriers.

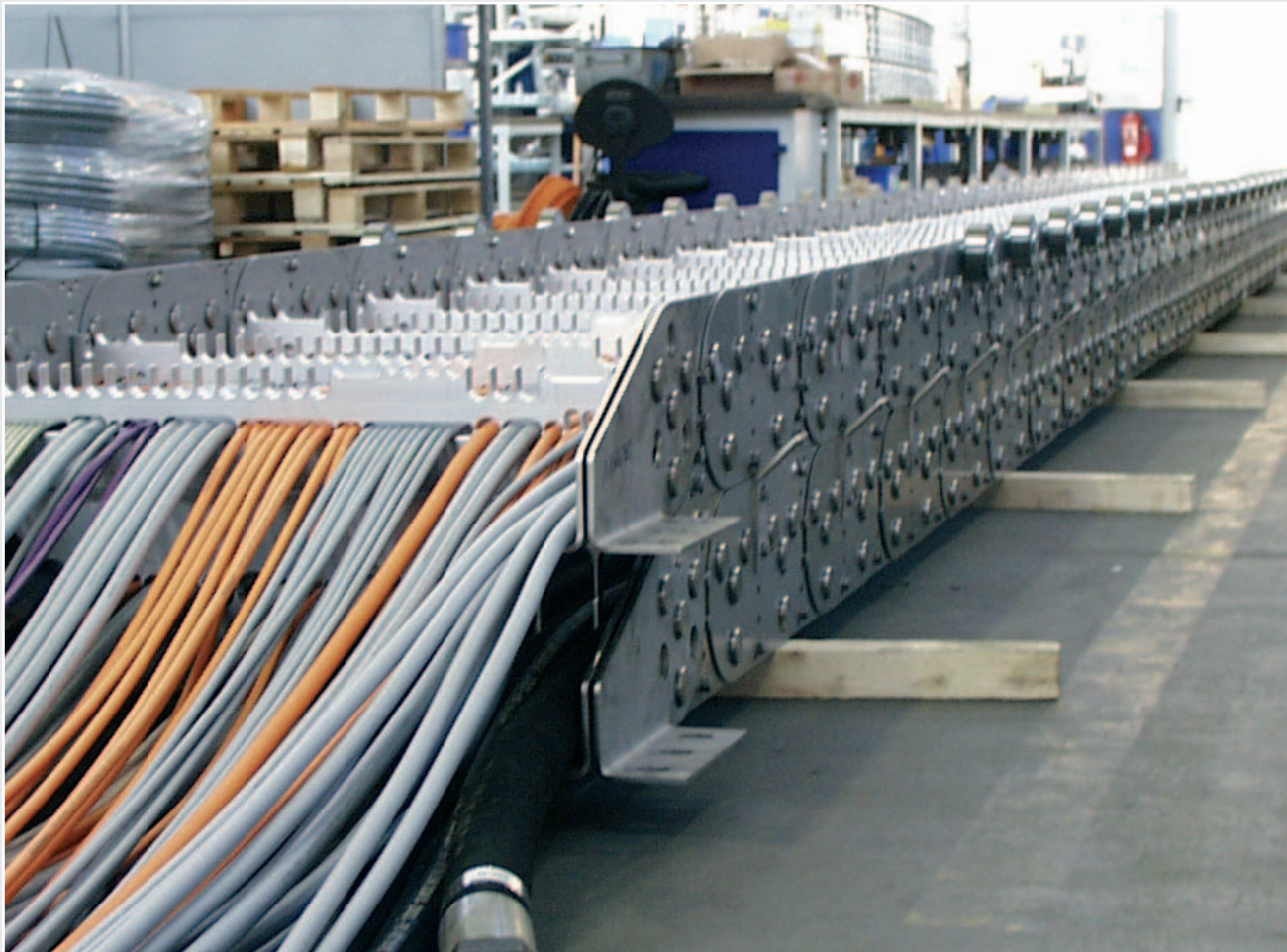

Steel cable carriers with TRAXLINE Cables for Motion.



Steel cable carriers in 4-band version.

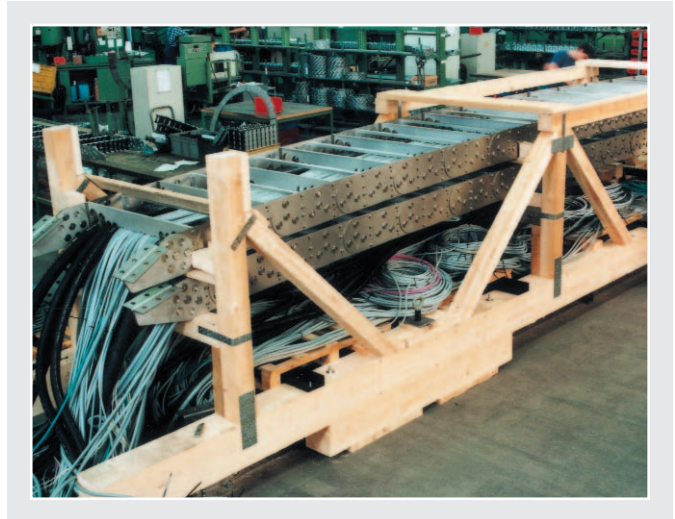

Steel cable carriers on transport frame.



Steel cable carriers on transport frame.



Steel cable carrier with load-bearing bolts.

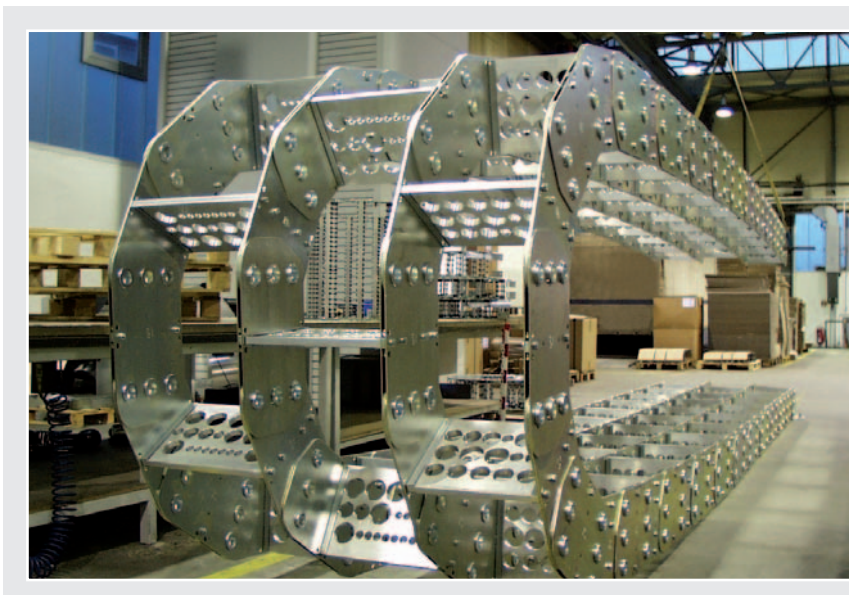

Steel cable carriers in 4-band version.





# KABELSCHLEPP